

Environmental Impact Assessment

October 2020

India: Chennai Metro Corridor 4

Main Report

Prepared by Chennai Metro Rail Limited (CMRL) for Project Lenders

CURRENCY EQUIVALENTS

(as of 1 July 2020)

Currency unit	–	Indian rupees (₹)
₹1.00	=	\$0.01401
\$1.00	=	₹75.5200

ABBREVIATIONS

ADB	:	Asian Development Bank
AIIB	:	Asian Infrastructure Investment Bank
CBTC	:	Communication based Train Control
CGWB	:	Central Ground Water Board
C&D	:	construction and demolition
CMA	:	Chennai Metropolitan Area
CMDA	:	Chennai Metropolitan Development Authority
CMRL	:	Chennai Metro Rail Limited
CPCB	:	Central Pollution Control Board
CMP	:	Comprehensive Mobility Plan
CMFRI	:	Central Institute of Mining and Fuel Research
CRZ	:	Coastal Regulatory Zone
EHS	:	Environmental, Health, and Safety
EIA	:	Environmental Impact Assessment
EMP	:	Environmental Management Plan
EMoP	:	Environmental Monitoring Plan
ESF	:	Environment and Social Framework
ESP	:	Environment and Social Policy
ESHS	:	Environment, Social, Health and Safety
FTA	:	Federal Transit Administration
GoI	:	Government of India
GoTN	:	Government of Tamil Nadu
GC	:	General Consultants
GRM	:	Grievance Redress Mechanism
IMD	:	India Meteorological Department
JICA	:	Japan International Cooperation Agency
KLD	:	Kilo Litres Per Day
MoEF&CC	:	Ministry of Environment, Forests and Climate Change
MDBs	:	Multilateral Development Banks
MRTS	:	Mass Rapid Transit System
NDB	:	New Development Bank
NAAQS	:	National Ambient Air Quality Standards
NBWL	:	National Board of Wildlife
NGT	:	National Green Tribunal
PAP	:	Project Affected Persons
RDSO	:	Railway Design & Standards Organisation
RAP	:	Resettlement Action Plan
SIPCOT	:	State Industries Promotion Corporation of Tamil Nadu
SPV	:	Special Purpose Vehicle
SIA	:	Social Impact Assessment

TNCZMA	:	Tamil Nadu Coastal Zone Management Authority
TBM	:	Tunnel Boring Machine
TNPCB	:	Tamil Nadu Pollution Control Board
WHO	:	World Health Organization

WEIGHTS AND MEASURES

°C	-	degree Celsius
dB(A)	-	decibel acoustic
ha	-	hectare
km	-	kilometer
km/h	-	kilometer per hour
kWe	-	kilowatt-electric
kV	-	Kilo volt(s)
kVA	-	kilo Volt-Amps
kW	-	kilowatt
m	-	meter
mm	-	millimeter
MVA	-	Megavolt Ampere
MW	-	Megawatt
m ³	-	cubic meter
m ³ /hr	-	cubic meters per hour
mg/l	-	milligrams per liter
m/s	-	meters per second
MTPA	-	metric tons per annum
MW	-	megawatt
ppm	-	parts per million
ppt	-	parts per thousand
rpm	-	revolutions per minute
µg/m ³	-	microgram per cubic meter

NOTES

- (i) The fiscal year (FY) of the Government of India ends on 31 March. FY before a calendar year denotes the year in which the fiscal year ends, e.g., FY2020 ends on 31 March 2020.
- (ii) In this report, "\$" refers to US dollars

TABLE OF CONTENTS

EXECUTIVE SUMMARY	8
1. INTRODUCTION	12
1.1 Background	12
1.2 Environmental Impact Assessment	1
2. POLICY, LEGAL AND ADMINISTRATIVE FRAMEWORK	5
2.1 The National (India) Environmental Laws, Policies and Regulations	5
2.2 International and Regional Agreements and Conventions	14
2.3 MDBs' Requirements Applicable to the Project	15
2.4 Applied Standards	15
3. PROJECT DESCRIPTION	16
3.1 Rationale	16
3.2 Description of the Corridor 4	17
3.3 Associated Facilities	24
3.4 Implementation Plan, Schedule and Cost	24
4. ENVIRONMENTAL BASELINE	26
4.1 Data Collection Methodology	26
4.2 Physical Environment	27
4.3 Ambient Environment	38
4.4 Ecological Environment	51
4.5 Socioeconomic Environment	58
5. ANTICIPATED IMPACTS AND MITIGATION MEASURES	60
5.1 Impacts Screening	60
5.2 Impacts and Mitigation Measures during Project Location and Design Phase	65
5.3 Impacts and Mitigation Measures During Construction Phase	70
5.4 Impacts and Mitigation Measures during Project Operation Phase	84
5.5 Impacts and Mitigation Measures Due to Depot	89
5.6 Chance Finds	90
5.7 Expected Benefits from Corridor 4	90
6. ANALYSIS OF ALTERNATIVES	93
6.1 Introduction	93
6.2 Different Modes of Transport and Need to Increase Public Transport Share	93
6.3 Analysis With and Without Project Scenario	93
6.4 Comparison of Alternative High Capacity Modes	93
6.5 Alternatives of Alignment, Stations and Depot Locations	94
7. PUBLIC CONSULTATIONS AND INFORMATION DISCLOSURE	96
7.1 Consultations	96
7.2 Identification of Stakeholders	96

7.3 Public Consultations	97
7.4 Information Disclosure	100
8. GRIEVANCE REDRESS MECHANISM	101
9. ENVIRONMENTAL MANAGEMENT PLAN	104
9.1 Introduction	104
9.2 Objectives of Environmental Management Plan	104
9.3 Institutional Arrangement	104
9.4 Environmental Monitoring and Reporting Program	106
9.5 Emergency Preparedness and Response System	157
9.6 Training and Capacity Building Programs	169
9.7 Environmental Management Budget and Resources	169
10 CONCLUSION AND RECOMMENDATION	170

LIST OF TABLES

Table 2-1: Summary of All Relevant Environmental Legislation to Corridor 4	6
Table 2-2: Applicable Permissions and Clearances Required for Corridor 4	9
Table 3-1: List of Stations –Corridor 4	17
Table 3-2: Land use abutting the Alignment	18
Table 3-3: Salient Features of Chennai Metro Corridor 4	19
Table 3-4: Water Requirement	Error! Bookmark not defined.
Table 4-1: Environmental Attributes and Data Source	26
Table 4-2: Details of Sampling / Monitoring Locations*	27
Table 4-3: Results of Laboratory Analysis of Soil Sample	29
Table 4-4: Soil Types along alignment	31
Table 4-5: Geological Formation in the Project Area	32
Table 4-6: Land Use in CMA	33
Table 4-7: Seismic Faults	36
Table 4-8: Monthly Highest Maximum Temperature (Deg C)	36
Table 4-9: Monthly Lowest Minimum Temperature (Deg C)	37
Table 4-10: Monthly Rainfall (mm)	37
Table 4-11: Monthly Mean Relative Humidity at 08:30 hrs (%)	37
Table 4-12: Monthly Mean Relative Humidity at 17:30 hrs (%)	37
Table 4-13: Results of Laboratory Analysis of Water Sample	40
Table 4-14: Ambient Air Quality	43
Table 4-15: National Ambient Air Quality Standards	43
Table 4-16: Ambient Noise Level Monitoring Results (by land use)	44
Table 4-17: Ambient Noise Level Monitoring Results (at sensitive receptors)	44
Table 4-19: Monitoring Schedule	48
Table 4-21: Baseline Vibration	50
Table 4-22: Bird Watching Areas in Chennai	55
Table 4-23: Guidelines for ESZ Activities	56

Table 4-24: Predominant Tree Species along the Corridor (Local name- Botanical name)	57
Table 4-25: Tree Cutting	58
Table 4-26: Heritage Assets near the Alignment	59
Table 5-1: Impacts Screening	61
Table 5-2: Organizations Responsible for Utilities and Services	67
Table 5-3: Heritage assets near the alignment	68
Table 5-4: Emissions due to truck movement during demolition and construction	73
Table 5-5: Average Noise Levels Generated by Operation of Various Construction Equipment	74
Table 5-6: Increase in Noise Levels Due to Increased Vehicular Movement	75
Table 5-7: Maximum Exposure Periods Specified By OSHA	76
Table 5-8: Construction Vibration Damage Criteria as per FTA guidelines	77
Table 5-9: Ground water level in Chennai District	81
Table 5-10: Exterior Noise Levels in Metro Stations	85
Table 5-11: Interior Noise Levels in Metro Trains	85
Table 5-12: Noise Barrier for Noise Reduction	85
Table 5-13: Water Demand	86
Table 5-14: Power Demand	87
Table 5-15: Reduction in Daily Vehicle kilometers	91
Table 5-16: Reduction in Fuel Consumption (million litre per year)	91
Table 5-17: Pollution Reduction (ton/year)	91
Table 6-1: Cost Comparison of urban mass transit systems	94
Table 7-1: Summary of Public Consultations Part 1	97
Table 7-2: Summary of Public Consultations Part 2	98
Table 7-3: Participation in Public Consultations by Location Part 2	99
Table 9-1: Monitoring and Reporting for EMP and EMoP	106
Table 9-2: Environmental Management Plan Matrix	108
Table 9-3: Environmental Monitoring Plan	154
Table 9-4: Emergency Preparedness and Response System	157
Table 9-5: Cost of EMP and EMoP Implementation	169

LIST OF FIGURES

Figure 1-1: Rail Transport Network in Chennai (Source: CMRL website)	13
Figure 1-2: Metro Network Phase 1 (Source: CMRL website)	14
Figure 1-3: Metro Network Phase 2	15
Figure 1-4: Corridor 4 (Source: DPR of Corridor 4, Oct 2018) Error! Bookmark not defined.	
Figure 1-5: Methodology of Environmental Impact Assessment	3
Figure 3-1: Corridor 4 (Source: DPR of Corridor 4, Oct 2018)	17
Figure 3-2: Typical Elevated Station	20
Figure 3-3: Typical Underground Station (2-level)	21
Figure 3-4: Layout Plan of Poonamallee Depot	22

Figure 3-5: Typical superstructure of viaduct	23
Figure 3-6: Typical Twin Tunnel Section	23
Figure 3-7: Implementation Plan and Schedule	25
Figure 4-1: Topographical setting of Project Area	27
Figure 4-2: Monitoring Locations	28
Figure 4-3: Soil Types in CMA	31
Figure 4-4: Land Use in Chennai Metropolitan Area 2006	33
Figure 4-5: Seismic Zone Map of India	34
Figure 4-6: Seismic microzonation of Chennai	35
Figure 4-7: Wind Rose Diagram for Chennai	38
Figure 4-8: Locations of noise monitoring at sensitive receptors on Corridor 4	44
Figure 4-9: Locations of vibration measurement at sensitive receptors Part 1	47
Figure 4-10: Locations of vibration measurement at sensitive receptors Part 2	47
Figure 4-11: Ecologically Sensitive Areas in CMA	51
Figure 4-12: Alignment in Ecologically Sensitive Area	52
Figure 4-13: Emergency Tsunami Reconstruction Project on Foreshore Road	53
Figure 4-14: Porur Lake	54
Figure 4-15: Forest Cover Map of Chennai District	54
Figure 4-16: Ecologically Sensitive Areas of Chennai District	56
Figure 5-1: Predicted MSL and HTL in Chennai Sector	69
Figure 5-2: Chennai Flood map 2015	70
Figure 5-3: Spatial Variation of Construction Equipment Noise Levels dB(A)	77
Figure 5-4: Vibration Damping Devices in Track	86
Figure 8-1: Grievance Redress Mechanism	102

LIST OF ANNEXURES

Annexure 1	: Baseline Environmental Monitoring Report
Annexure 2	: Environmentally sensitive receptors located within 200m on either side of alignment
Annexure 3	: Acceptable Vibration Impact Criteria
Annexure 4	: Utility Network Information
Annexure 5	: Environment, Social, Health and Safety Requirements
Annexure 6	: Terms of Reference of General Consultant in Implementation of EMP and EMoP
Annexure 7	: Terms of Reference for Engaging External Monitoring Agency/Expert
Annexure 8	: Guidance for Construction Workers/ Contractors In View Of COVID-19

EXECUTIVE SUMMARY

1. Chennai, the capital city of the state of Tamil Nadu, is part of the Chennai Metropolitan Area (CMA) that is home to over 8.65 million people and plays a vital role in the economy of South India.¹ Like other metropolitan areas in the country, CMA is currently facing the challenges of accelerated urbanization growth that have considerably strained the area's transportation system. The increase in economic activities has boosted the regional economy and job creation, which in turn necessitates improvement in ease of travel and connectivity.
2. Chennai Metro Rail Limited (CMRL), a joint venture of the Government of India (GoI) and the Government of Tamil Nadu (GoTN) with equal equity ownership, is responsible for implementing, operating, and maintaining the city's metro system. CMRL developed the Comprehensive Mobility Plan for CMA in 2015 and identified three corridors (corridors 3, 4, and 5) for the second phase of the Chennai Metro Rail to alleviate CMA's transportation capacity constraints.
3. GoI requested the Multilateral Development Banks² (MDBs) to assist the implementation of the 25.8 km of Chennai metro corridor 4 upto depot entry, which consists of 15.8 km of elevated section and 10.0 km of underground section. This line has 4 stations in common with Corridor 5, offers interchange with Corridor 3, Phase I Metro and MRTS; it connects with suburban railway system. This alignment has been finalized after examining alternatives. The total capital cost of Corridor 4 is estimated to be USD 2.17 billion. It is estimated that project will be implemented over a period of 6 years from the date of commencement. CMRL will take full responsibility of the implementation of Corridor 4.
4. As per provisions of the Environmental Impact Assessment (EIA) Notification 2006 and its subsequent amendments by the Ministry of Environment, Forests and Climate Change (MoEF&CC), Metro Rail Projects are exempted from requirements of Environmental Clearance. However, the Light House to Thirumayilai Metro station will fall in Coastal Regulatory Zone (CRZ) II and IV-B and CRZ clearance will be required as per CRZ Notification 2019.
5. This EIA comprising baseline data on existing conditions of physical, ambient and ecological environment, together with the identified and anticipated environmental impacts and proposed mitigation measures, has been prepared in accordance with GoI's legislative framework and MDBs' environmental safeguard policies³. In accordance with proposed packaging of Corridor 4, underground stretch, elevated stretch and depot will be financed by different MDBs but will not be considered as Associated Facilities. AIIB counts all co-financiers' components as one Project. The environmental impacts and mitigation measures of all 4 packages are analyzed in this report. Corridor 4 overall is expected to generate environmental and socio-economic benefits in terms of decreasing air pollution from traffic congestion and serving the growing travel demand. As per MDB's safeguard policies, the Corridor 4 has been categorized as "Category A" due to the significant impacts anticipated during construction.
6. Corridor 4 consists of 9 underground stations from Lighthouse to Meenakshi College, 18 elevated stations from Power House to Poonamallee Bypass and one depot at Poonamallee Bypass. The depot will have capacity for 31 trains of 6 cars for maintenance and repairs of the operational rolling stock. Standard Gauge (1435mm) will be adopted with a minimum track center distance of 4000 mm, 16-ton maximum axle load capacity and a design speed of 80 kmph. The elevated station is generally located on the road median 140 m long and 24 m wide and is a three level structure, with a minimum vertical clearance of 5.50 m under the concourse. To reduce physical and visual impact of the elevated station,

¹ Indian National Census, <https://www.census2011.co.in/census/metropolitan/435-chennai.html> The Census Organization of India, 2011.

² Asian Development Bank (ADB), Asian Infrastructure Investment Bank (AIIB) and New Development Bank (NDB).

³ ADB's Safeguard Policy Statement (SPS) 2009, AIIB's Environmental and Social Framework (ESF), and NDB's Environmental and Social Framework (ESF).

stations have been made transparent with minimum walls on the sides. The underground station is two- or three-level station with entrances and ventilation shafts at the ground level, a concourse with ticketing and automatic fare collection system (AFCs) at the mezzanine level and finally 140 m long and 12 m wide island platforms at the lowest level. 25 kV AC traction system and Communication based Train Control (CBTC) Signaling system shall be adopted for Corridor 4. Rolling stock is of light weight stainless steel/aluminum body for energy efficiency. Universal accessibility has been reflected in the design following international best practices. Green building features like rainwater harvesting, solar energy panels at elevated stations' roofs, energy efficient air conditioning and lightning will be considered in station design.

7. The terrain along Corridor 4 alignment is mostly flat, no more than 3 m above mean sea-level. The Geotechnical Investigation is ongoing with the results showing that the soils are slightly alkaline with dominant types of sandy and clay. The section of alignment from Light House to Kutcheri Road is located in CRZ II and the section between Kutcheri Road to Thirumayilai station is located in IV-B. The CRZ II stretch is defined as areas that have already been developed up to or close to the shore-line. 536 trees are likely to be felled along the corridor up to Poonamallee Bypass depot. Three assets, namely Santhome Church, Rosary Church and Our Lady of Light Shrine are located on at distance within 100m from Corridor 4.

8. Despite the seemingly abundant sources of water, Chennai suffers continuously from water stress since the entire basin is dependent on rainfall. Water quality was sampled at 9 locations. Most of the parameters are well within the prescribed permissible limits as per the Bureau of Indian Standards. However, the concentration of Total Dissolved Solids and Total Hardness are observed to be higher than the prescribed limits as per the IS for the water samples collected at Santhome Church this could be due to higher salinity and mineral content (Calcium and Magnesium) in the groundwater.

9. Results of the air monitoring show that air quality was moderate, while the parameters of Sulphur Dioxide (SO₂) and Nitrogen Dioxide (NO₂) were within the permissible level of National Ambient Air Quality Standards (NAAQS) and World Health Organization (WHO) guideline. Particulate Matter was within NAAQS but exceeded WHO guideline. Concentration of Carbon Monoxide (CO) exceeded the permissible level of NAAQS in all the monitoring locations but was generally within WHO guideline. The noise levels monitored at 8 locations along the alignment were above the national and international permissible limits. Noise levels was also monitored at 30 sensitive locations belonging to the silence zone, with 60% slightly exceeding Ambient Noise Standard of 50dB the daytime limit (23.3% per WHO guideline of 55dB), and 1 out of 30 exceeding 40 dB the night-time limit. The peak particle velocity baseline values to demonstrate the vibration level at 11 out of 13 monitored locations is found to exceed acceptable criteria for ground borne vibration prescribed by Federal Transit Administration (FTA) USA and Railway Design & Standards Organization (RDSO) India which are more valid for operation of this project. However, the observed levels at all 13 locations are well below the construction vibration damage criteria for blasting which are relevant only if blasting is undertaken during construction as per Central Institute of Mining and Fuel Research (CMFRI) India. A full baseline will be collected prior to contractor's mobilization to elaborate the current baseline.

10. Based on analysis of project and environmental settings, a detailed assessment of potential impacts due project location and design, construction and operation has been carried out. For each of these adverse impacts, mitigation measures have been proposed. The key positive environmental impacts of Corridor 4 include reduced use of private vehicle leading to reduction in pollutants; road safety improvements; increased accessibility and mobility, and a modest reduction in greenhouse gas emissions. The main residual negative impacts of Corridor 4 include fugitive and point source dust emission, surface noise and vibration from excavation and demolition, disturbance to road traffic, disposal of large quantities of construction and demolition wastes, and occupation and community health and safety, which are mainly temporary and localized. The detailed analysis of noise and vibration has been finalized and is available as a separate Noise and Vibration study report. The results will be incorporated in the updated EIA prior to contractor's mobilization.

11. The main mitigation measures proposed are as follows: (i) to plant twelve saplings for each tree to be cut as against ten saplings ordered for infrastructure projects by the Honorable Madras High Court, with estimated compensatory afforestation cost in place accordingly; (ii) noise reduction measures (i.e. noise barriers at sensitive receptor locations); and (iii) reuse of excavated material where feasible and disposal of construction waste in a regulated manner. Corridor 4 will take into consideration the climate change effects of an anticipated continuous increase in ambient temperature, intensity of cyclones and storm surge, heavy precipitation events, and sea level rise in the future. Several climate change considerations to be integrated into Corridor 4 design include: (i) installation of floodgates at stations with flooding risks; (ii) improving adaptability to seasonal thermal variations in the stations through the use of large open spaces for unrestricted air movement, cross-ventilation and ensuring that enclosed areas are well ventilated; (iii) designing for better adaptability to rising sea level/high tide/heavy flooding through the use of higher plinth levels and check valves for sewer lines in flood-prone areas and the use of resilient materials that can get wet and then dry out with minimal damage; (iv) using solar panels on station buildings and roofs to reduce the extensive use of grid-generated electricity supplied to the station for its operation and maintenance; and (v) through better station roof design, providing for rainwater harvesting by channeling rainwater through gutters and pipes to either harvesting pits in the ground or to recharge groundwater.

12. Various alternatives such as modes of transport, alignment, proposed design etc. have been considered and analyzed for its likely impacts on various environmental parameters. Additionally, an evaluation of potential environmental impacts in terms of 'with' and 'without' project situation has been considered for the justification of Corridor 4.

13. Meaningful consultations were carried out with various stakeholders during EIA preparation and will continue throughout Corridor 4 implementation. Women felt that Corridor 4 will provide (i) better access to higher levels of education, health services (especially in emergencies), and social interactions; (ii) better transport option; and (iii) increase in leisure time. Concerns voiced by Project Affected Persons (PAPs) and stakeholders have been incorporated in Corridor 4 design. Individual consultation of PAPs will also be carried out during implementation. Information disclosure will follow the procedure for MDBs' Category A projects.

14. Grievance Redress Mechanism (GRM) has been proposed for Corridor 4 comprises the procedures to address grievances i) first at the Project Implementation Unit (PIU) level, ii) second at Grievance Redress Committee (GRC), to ensure grievances from PAPs and workers are addressed to facilitate timely project implementation. A GRC will be formed which will have representatives from Contractors, General Consultant (GC), CMRL, local administration, and PAPs. Unsatisfied PAPs will have the option to escalate the grievances at any point of time.

15. An Environmental Management Plan (EMP) with institutional arrangements, budgetary provisions, schedule for EMP implementation and its monitoring has been prepared, including appropriate mitigation measures, provisions related to occupational health and safety, labour camp and construction site management, and traffic and public utility management etc. to address all impacts during Project pre-construction, construction and operation phases. The EMP has been developed in conjunction with general safety, health and environment provisions (which are included in the standard bidding document) and it forms part of the contract document of the contractors. Bi-annually monitoring reports will be prepared by GC and submitted to MDBs through CMRL. A third-party monitor will also supervise work independently and submit bi-annual reports to CMRL and MDBs. The preliminary estimated cost of the EMP including implementation and monitoring is USD 3.19 million (INR 227.9 million). This cost estimate is exclusive of land acquisition and resettlement & rehabilitation cost.

16. Benefits far outweigh negative impacts. Overall, the major social and environmental impacts associated with Corridor 4 are limited to the construction period and can be mitigated to an acceptable level by implementation of recommended measures and by best engineering and environmental practices. In addition, stringent monitoring requirements and actions have been included in the Environmental

Monitoring Plan (EMoP) on noise and vibration levels that will be generated during construction. CMRL shall ensure that the EMP and EMoP are included in Bill of Quantity and forms part of bid document and civil works contract. The same shall be revised if necessary, during project implementation or if there is any change in the project design and with approval of MDBs.

17. This EIA report is structured as following: (i) Introduction of background, methodology of preparation of the report; (ii) Policy and legal framework within which environmental safeguards for Corridor 4 shall be recommended and implemented; (iii) Project description with enumeration of salient features of Corridor 4 which have bearing upon its environmental impacts; (iv) Environmental baseline of Corridor 4 in terms of physical, ambient, and ecological baseline (socioeconomic baseline will be presented in Social Impact Assessment Report); (v) Identification of negative and positive impacts arising from pre-construction, construction and operation of Corridor 4 and respective measures to mitigate negative impacts and where feasible enhance generate positive impacts; (vi) Analysis of alternatives including its need and alternatives of technology and alignment; (vii) Consultations with stakeholders and plan for disclosure of project information; (viii) Mechanism for stakeholders to communicate grievances and suggestions and for their Redressal; (ix) EMP and institutional arrangement for implementation of environmental impact mitigation measures; and (x) Conclusion.

1. INTRODUCTION

1.1 Background

1. Chennai Metropolitan Area (CMA) comprises the city of Chennai, 8 Municipalities, 11 Town Panchayats and 179 Village Panchayats in 10 Panchayat Unions. The extent of CMA is 1,189 sq.km. The CMA falls in three Districts of Tamil Nadu viz. Chennai District (176 sq.km), part of Tiruvallur District (637 sq.km), and part of Kancheepuram District 376 sq.km). In year 2011, resident population of CMA was 8.65 million.

2. Chennai, the capital city of the state of Tamil Nadu, plays a vital role in the economy of South India.⁴ The Chennai Metropolitan Development Authority (CMDA) devised the Chennai Second Master Plan 2026 and estimated that the population would grow to 12.6 million people with an estimate of daily passenger traffic of 20.8 million in 2026.⁵ CMA has emerged as a leading national automotive hub with major manufacturers including Ford, Hyundai, Renault, Nissan, Daimler (Mercedes) operating their plants in the area. CMA also houses a growing number of software firms (including Infosys, TCS, Wipro etc.), financial services (KPMG, Deloitte, Price water house Coopers etc.) and call centers. Like other metropolitan areas in the country, CMA is currently facing the challenges of accelerated urbanization growth that have considerably strained the area's transportation system. The increase in economic activities has boosted the regional economy and job creation, which in turn necessitates improvement in ease of travel and connectivity.

3. The existing transportation system in CMA is marked by high traffic density, carbon emissions, and frequent road incidents. In addition to the high volume of vehicles and already congested roads, inadequate parking space and the encroachment of street space by vendors on major road have exacerbated the traffic congestion. Major roads along the proposed project alignments are forecast to function beyond respective design service volume in year 2035 in absence of the project lines. The accelerating use of private vehicles has put Chennai in the fifth rank in carbon emission from the transport sector among 54 South Asian cities.⁶

4. Inadequate transportation infrastructure and poor service have resulted in an unfavorable decrease in the share of public transport from 54 percent in 1970 to 28 percent in 2014.⁷ The Chennai Second Master Plan 2026 proposes to increase the public and private mode split to 70:30. The mass transit transportation, especially an integrated metro system will be essential to achieve this intended split.

5. The city has two mainline railway terminals. Urban Mass Rapid Transit System (MRTS) of 19.35 km from Chennai Beach to Velachery is in operation, land acquisition for balance MRTS section from Velachery to St Thomas Mount is in process. Chennai Metro Phase 1 of 45 kms is in operation, work on extension to Thiruvottiyur is in progress. Chennai suburban railway network supplements MRTS. Schematic diagram of urban mass rapid transit network is in Figure 1.1.

⁴ Indian National Census, <https://www.census2011.co.in/census/metropolitan/435-chennai.html> The Census Organization of India, 2011.

⁵ Second Master Plan for Chennai Metropolitan Area 2026, Chennai Metropolitan Development Authority, 2008.

⁶International Council for Local Environmental Initiative Study, 2012.

⁷ Comprehensive Detailed Project Report for Chennai Metro Phase-II, Chennai Metro Rail Limited, 2018.

Figure 1-1: Rail Transport Network in Chennai (Source: CMRL website)

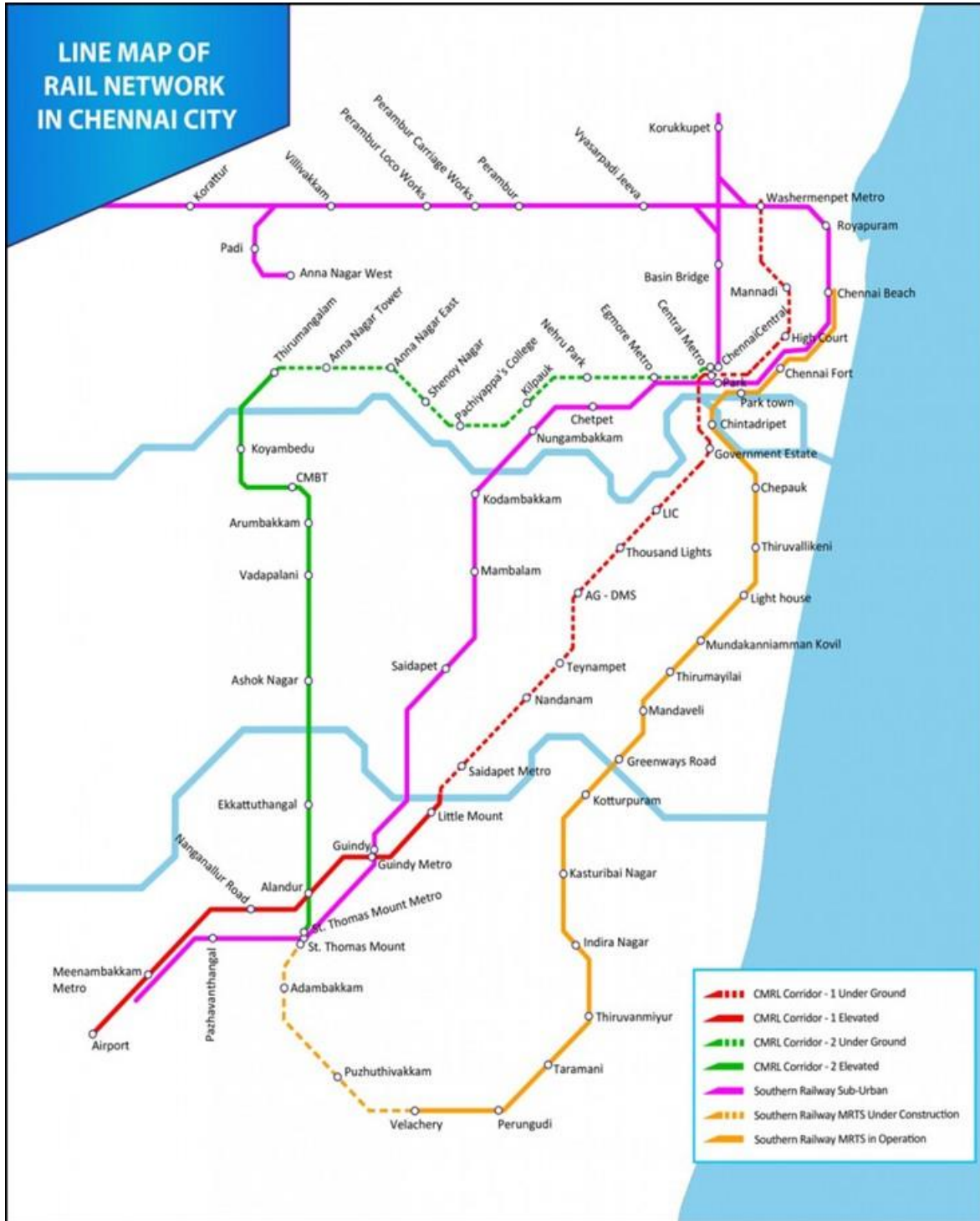

1.1.1 Chennai Metro Network

6. **Phase 1** of Chennai metro as shown in Figure 1.2 covers 54.05 km in two corridors - Washermanpet to Airport (23.09 Km), Chennai Central to St. Thomas Mount (21.96 Km) via Koyambedu and extension from Washermanpet to Wimco Nagar (9.00 km) in Thiruvottiyur. As on February 2020, Phase 1 excluding the extension from Washermanpet to Thiruvottiyur is in commercial operation.

Figure 1-2: Metro Network Phase 1 (Source: CMRL website)



7. Phase 2 includes Corridor 3, 4 and 5 as shown in Figure 1.3. The final alignments will be decided based on engineering designs.

Figure 1-3: Metro Network Phase 2

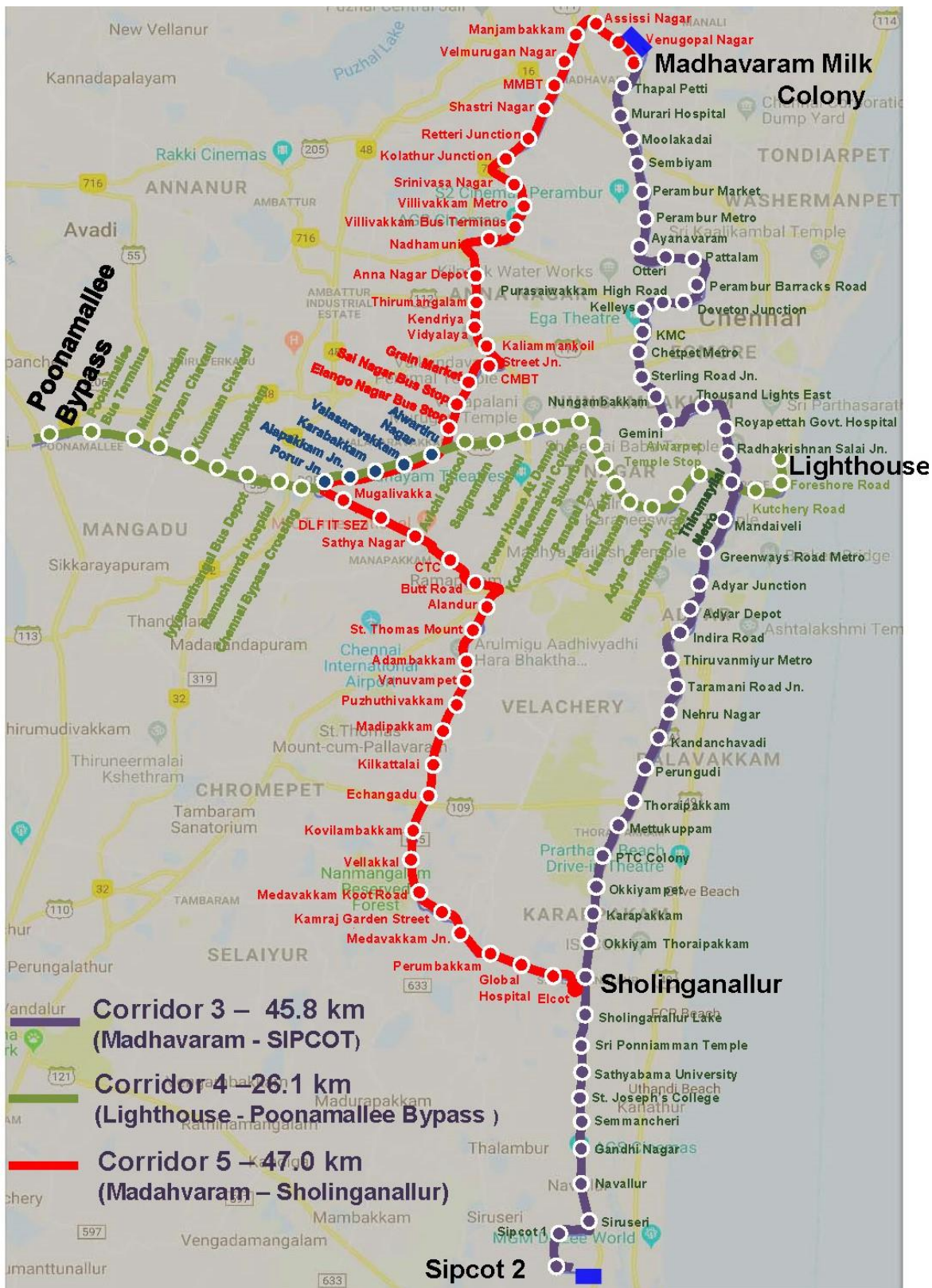

Source: Comprehensive DPR Chennai Metro Phase 2, RITES, Dec 2018

8. **Corridor 3** Madhavaram to SIPCOT, Revenue length of the corridor is 45.813 km up to depot entry comprising underground length 26.723 km and 30 underground stations; elevated length 19.090 km and 20 elevated stations. It provides interchange with Corridor 4 and Corridor 5. It offers interchange with Phase I Metro and MRTS and connects with suburban railway system.

9. **Corridor 4** Lighthouse to Poonamallee bypass, Revenue length of the corridor is 25.8 km comprising underground length 10.0 km and 9 underground stations (Lighthouse to Meenakshi College) and elevated length 15.8 km and 18 elevated stations (Power House to Poonamallee bypass). Corridor 4 has 4 stations (the latest alignment of Corridor 5 shows the Porur Jn station will be avoided by Corridor 5) in common with Corridor 5, offers interchange with Corridor 3, Phase I Metro and MRTS; it connects with suburban railway system.

10. **Corridor 5** Madhavaram to Sholinganallur, Revenue length of the corridor is 47.008 km comprising 41.173 km elevated length and 5.835 km underground length and balance as mix of underground station, ramp and at-grade station; it comprises one at grade station, 41 elevated stations and 6 underground stations. It is integrated with Phase I Metro and MRTS; connects with suburban railway system.

1.1.2 Nature, Size and Location of Corridor 4

11. **Figure 1.4 shows the alignment and station plan of Corridor 4.**

Figure 1-4: Route of Corridor 4 (Updated April 2021)

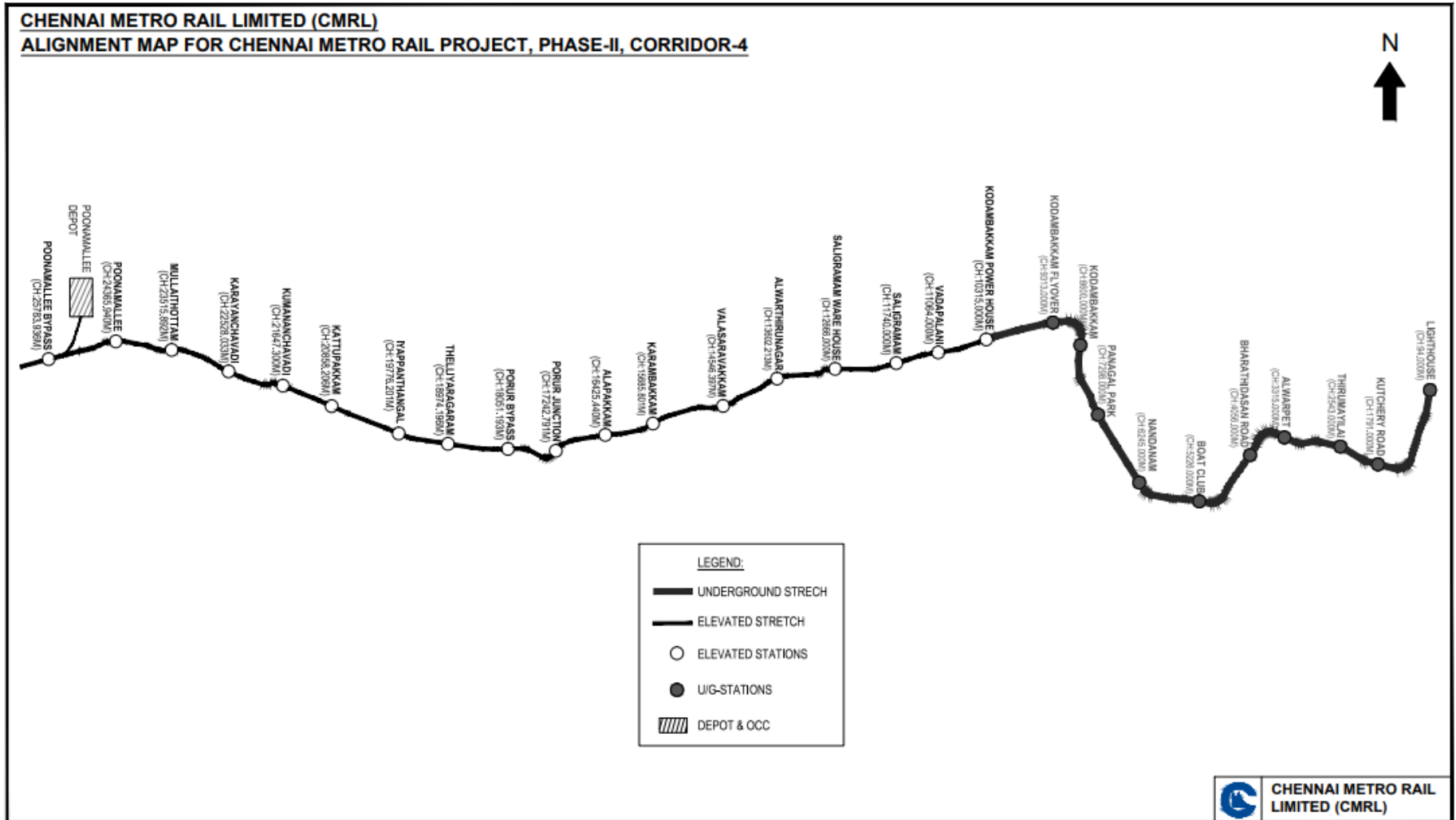

12. Corridor 4 is financed in parallel by:
- Asian Development Bank (ADB) includes Alignment and formation/tunneling (10.0 km from Lighthouse to Meenakshi College), 9 underground stations structural civil cost.
 - Asian Infrastructure Investment Bank (AIIB) includes Alignment and formation (15.8 km from Power House to Poonamallee bypass), 18 Elevated stations structural civil cost.
 - New Development Bank (NDB) includes P. way, station building components VAC and TVS, E&M, Lifts and Escalators, Architectural finishes and MMI.
 - Government will finance the remaining components including Depot, Rolling Stock and General Consultancy.
13. These three institutions are collectively termed in this report as Multilateral Development Banks (MDBs).
14. The Government of Tamil Nadu (GoTN) has created a Special Purpose Vehicle (SPV) for implementing the Chennai Metro Rail Project. This SPV named as “Chennai Metro Rail Limited (CMRL)” was incorporated on 03.12.2007 under the Companies Act. It has now been converted into a Joint Venture of Government of India (GoI) and GoTN with equal equity holding. CMRL as the implementing agency, shall be responsible for implementing, operating, and maintaining the city’s metro system. CMRL developed the Comprehensive Mobility Plan for CMA in 2015 to identify the present and future mobility patterns of CMA. The detailed study identified three corridors (corridors 3, 4, and 5) for the second phase of the Chennai Metro Rail to alleviate CMA’s transportation capacity constraints.

1.2 Environmental Impact Assessment

1.2.1 Categorization

15. The environmental screening has been carried out for Corridor 4 as per MDBs’ policies. Based on preliminary assessment of significance of impacts borne out of field visits and secondary information, Corridor 4 will entail significant adverse impacts. Although, the proposed project will bring in many benefits to the area, there is potential for environmental impacts on the physical cultural structures due to vibration from tunneling works during construction and future operation of the metro. Impacts on structures also come from the shallow foundation which may bring damage due to subsidence, particularly for those close to the alignment. The civil works pose significant environment, health and safety risks as well. Therefore, the project has been classified as category ‘A’ and requires full impacts assessment to be documented in an Environmental Impact Assessment (EIA) Report per MDBs’ requirement.

1.2.2 Purpose of the EIA Report

16. This EIA report documents the environmental assessment of Corridor 4 and identifies the environmental issues to be considered at planning and design stage. In this report, the different activities that are likely to take place during construction and operation, have been analysed and the potential impacts that may accompany them have been discussed. The EIA addresses the environmental management requirements of GoI and the MDBs. In general, the EIA Report is outlined as below to address various aspects:

- Provide background of the project in terms of land use, existing Metrorail network and the proposed Metrorail corridors, methodology of preparation of the report and its content;

- Analysis of policy and legal framework within which environmental safeguards for the project shall be recommended and implemented;
- Provide information about the baseline environmental settings;
- Provide information on potential environmental impacts of Corridor 4 with its magnitude, distribution, and duration;
- Provide information on required mitigation measures with cost to minimize the impacts;
- Analysis of the alternatives considering alternative locations, designs, management approaches, for selection of most feasible and environmental acceptable options;
- Provide details of stakeholders' consultations;
- Plans for stakeholders to communicate grievances and suggestions and for their Redressal; and
- Formulate environmental management and monitoring plan with institutional measures for effective implementation of mitigation measures proposed.

17. Social Impact Assessment (SIA) with a Resettlement Action Plan (RAP) for implementation is presented as a separate Report.

1.2.3 Approach and Methodology

Figure 1-4: Methodology of Environmental Impact Assessment

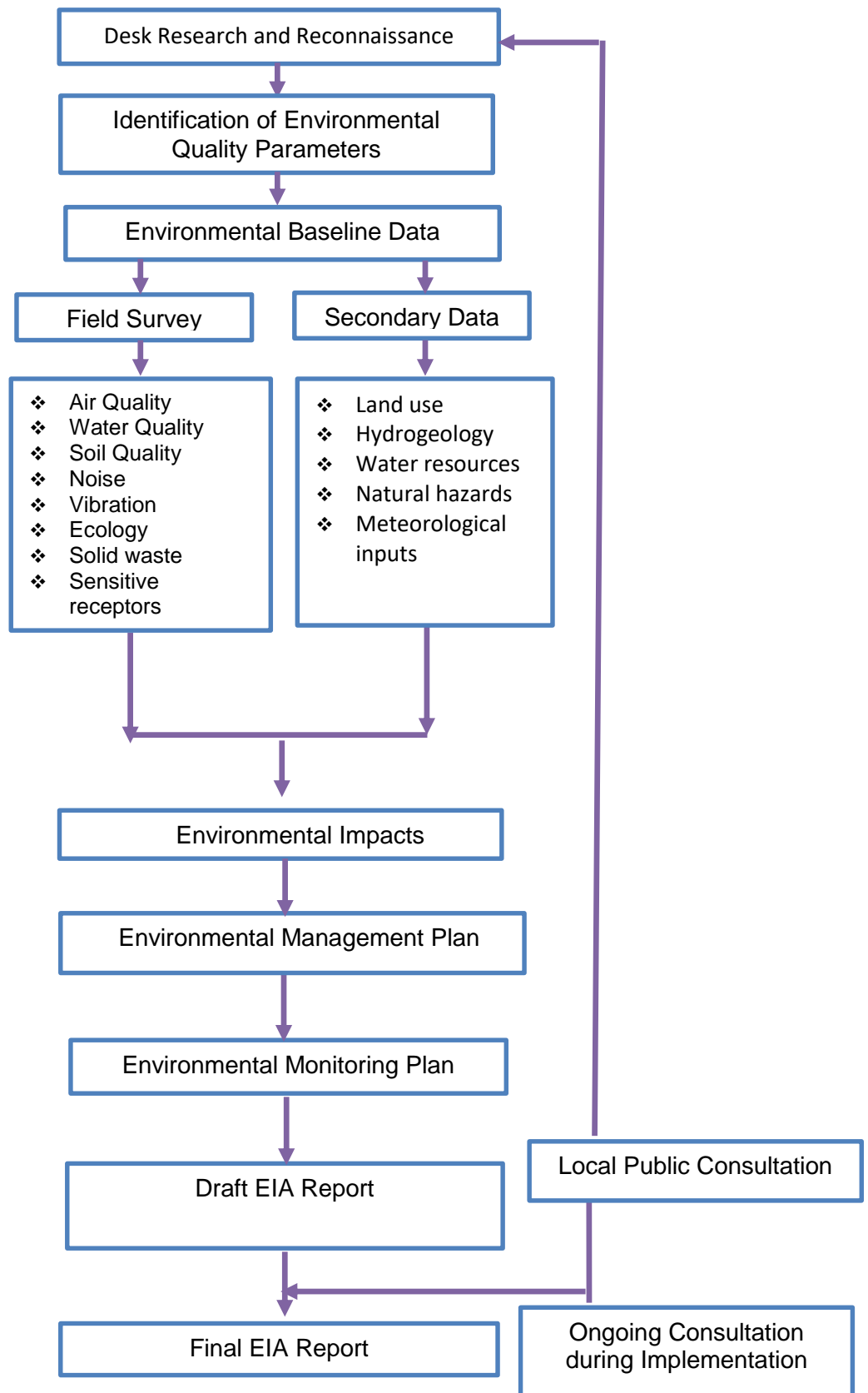

18. As shown in Figure 1.5, the EIA followed a number of steps:
- Review of available baseline reports, and technical reports/studies related to Corridor 4;
 - Conduct field visits to collect primary or secondary data relevant to Corridor 4 areas to establish the baseline⁸;
 - Assess the potential impacts on environmental attributes due to the location, design, installation and operation of Corridor 4 through field investigations and data analysis;
 - Explore opportunities for environmental enhancement and identify measures;
 - Prepare an environment management plan (EMP) outlining the measures for mitigating the impacts identified including the institutional arrangements;
 - Identify critical environmental parameters required to be monitored subsequent to the implementation of Corridor 4 and prepare an environmental monitoring plan;
 - Carry out consultation with key stakeholders and administrative authorities to identify their perception on Corridor 4, introduce project components and anticipated impacts; and,
 - Disclose the draft EIA, including the Executive Summary in local language at CMRL and MDBs' websites to be made publicly available.

⁸ The Baseline data for air, water and soil quality was collected in width 75m on either side of proposed centre line of alignment, and data for noise and vibration in width 200m on either side of alignment. Sensitive receptors located in width 100m on either side of centre line of alignment were identified according to the silence zone defined by the Central Pollution Control Board.

2. POLICY, LEGAL AND ADMINISTRATIVE FRAMEWORK

19. India has well defined institutional and legislative framework. The legislation covers all components of environment viz. air, water, soil, terrestrial and aquatic flora and fauna, natural resources, and sensitive habitats. India is also signatory to various international conventions and protocols. The environmental legislations in India are framed to protect the valued environmental components and comply with its commitment to international community under above conventions and protocols. MDBs have also defined its Environmental and Social Policies. This chapter will describe the applicability of above laws and regulations, conventions, protocols, and safeguards.

20. The laws, regulations, policies and guidelines applicable to this project based on the location, design, construction and operation are summarized in the subsequent sections in following order.

- National (India) Environmental Legislation and Legal Administrative Framework,
- ADB, AIIB and NDB environmental and social policies and standards, and
- Summary of international treaties and applicability to the project.

2.1 The National (India) Environmental Laws, Policies and Regulations

21. Gol's environmental legal framework comprises a set of comprehensive acts and regulations aimed at conserving various components of the biological and physical environment including environmental assessment procedures and requirements for public consultation. As per the EIA notification 2006, railway projects are not covered under the notification and hence environmental clearances related requirements do not envisage, this is applicable for metro rail projects as well. However, Corridor 4 will require Coastal Regulation Zone (CRZ) Clearance per the CRZ Notification 2019. Other relevant environmental legislations are mentioned in the Table 2.1.

2.1.1 Coastal Regulation Zone applicable to the Project

22. Alignment of the Corridor 4 passes through CRZ II and IV-B according to the CRZ Notification 2019. CRZ clearance needs to be obtained from Tamil Nadu Coastal Zone Management Authority (TNCZMA). Under the regulation, Gol declared the coastal stretches of seas, bays, estuaries, creeks, rivers and backwaters which are influenced by tidal action (in the landward side) up to 500 metres from the High Tide Line (HTL) and the land between the Low Tide Line (LTL) and the HTL as CRZ with four categories.

23. As per CRZ Notification 2019, construction in CRZ IV-B area where the alignment passes through the Buckingham canal (tidal influenced water bodies), shall be permitted subject to a detailed marine or terrestrial or both environment impact assessment, to be recommended by TNCZMA and approved by the Ministry of Environment, Forest and Climate Change (MoEF&CC). Construction in CRZ II area, CRZ II permission is required from TNCZMA.

2.1.2 Metro Rail Policy 2017

24. Gol's Union Cabinet approved a new Metro Rail Policy in 2017 that aims to enable the development and implementation of metro projects in a comprehensive and sustainable manner from the social, economic, and environmental perspectives. The Policy improves the integrated management of Metro development in three main aspects, (i) The new policy proposes that every city should setup a Unified Metropolitan Transport Authority for planning and developing multimodal transportation, which enable the overall planning and

development of all modes of transport under the strong lead institutions; (ii) The need to carry out an alternative analysis is a welcome addition in the policy to help in better system selection; and (iii) The requirement to look at the 5-km catchment area for providing feeder services through walking, cycling and para-transit modes is promising.

2.1.3 Legislations Relevant to the Project

25. The policies and requirements which are most relevant in the context of this Corridor are provided in Table 2.1 below.

Table 2-1: Summary of All Relevant Environmental Legislation to Corridor 4

Sl No.	Legislation	Objective	Responsible Institution
1.	Environment (Protection) Act (1986) and Rules (1986); National Conservation Strategy and Policy Statement on Environment and Development of 1992; National Environment Policy of 2006	To protect and improve the overall environment	MoEF&CC
2.	EIA Notification under Environmental Protection Rules (2006, 2009, 2011) and relevant Office Memorandums (OM)	To provide guidance on environmental clearance requirements and clarification on related specific technical issues	MoEF&CC
3.	CRZ Notification, 2019	To ensure livelihood security to the fishing communities and other local communities living in the coastal areas; To conserve and protect coastal stretches and; To promote development in a sustainable manner based on scientific principles, taking into account the dangers of natural hazards in the coastal areas and sea level rise due to global warming	TNCZMA and MoEF&CC
4.	The Wildlife Protection Act (1972 and amended in 1993)	To protect wild animals and birds through the creation of National Parks and Sanctuaries	MoEF&CC

Sl No.	Legislation	Objective	Responsible Institution
5.	The Noise Pollution (Regulation and Control) Rules, 2000 (Amended 2002)	To provide for the prevention and control of noise pollution and for the establishment of Boards to carry out these purposes	Central Pollution Control Board (CPCB)
6.	Metro Rail Transit System, Guidelines for Noise and Vibrations, RDSO, Ministry of Railways, September 2015	To provide for the prevention and control of vibration	NA
7.	The Water (Prevention and Control of Pollution) Act 1972 (Amended 1988) and Rules 1974	To provide for the prevention and control of water pollution and the	CPCB
8.	The Tamil Nadu Water (Prevention and Control of Pollution) Rules, 1983 amended May 2009	maintaining or restoring of wholesomeness of water	Tamil Nadu Pollution Control Board (TNPCB)
9.	Model Groundwater (Control and Regulation) Bill 1970, amended in 1972, 1996 and 2005	To provide for the prevention, control and abatement of groundwater pollution	Central Ground Water Authority (CGWA)
10.	The Air (Prevention and Control of Pollution) Act, 1981(Amended 1987) and Rules 1982	To provide for the prevention, control and abatement of air pollution, and for the establishment of Boards to carry out these purposes	CPCB
11.	Solid Waste Management Rules, 2016	Provisions for collection, storage segregation, transportation, processing and disposal of municipal solid wastes	TNPCB
12.	Hazardous and Other Wastes (Management and Transboundary Movement) Amendment Rules 2019	To protection the general public against improper handling, storage and disposal of hazardous wastes	TNPCB
13.	The Forest (Conservation) Act 1980 (Amended 1988) and Rules 1981 (Amended 2003); National Forest Policy of 1998	To protect and manage forests	MoEF&CC

SI No.	Legislation	Objective	Responsible Institution
14.	Construction and Demolition Waste Management Rules, 2016	Large generators (who generate more than 20 tons or more in one day or 300 tons per project in a month) shall submit waste management plan and get appropriate approvals from the local authority before starting construction or demolition or remodeling work	TNPCB
15.	The Mines and Minerals (Development and Regulation) Act, 1957	To protect the environment from quarry operation	State Department of Geology and Mines
16.	Central Motor Vehicle Act (1988) and Rules (1988)	To control vehicular air and noise pollution. To regulate development of the transport sector, check and control vehicular air and noise pollution	Transport Commissionerate and State Transport Authority
17.	Indian Treasure Trove Act, 1878 (as modified up to September 1949); Ancient Monuments and Archaeological Sites and Remains Act (1958)	Conservation of Cultural and historical remains found in India Chance find during construction	Archaeological Survey of India
18.	Annexure XXV, Special Rules for conservation of Heritage Buildings Vol II: Second Master Plan for Chennai Metropolitan Area 2026 amended May 2013	To protect heritage assets	Chennai Metropolitan Development Authority (CMDA)
19.	National Policy on HIV/AIDS and the World of Work National Policy on Safety, Health and Environment at Workplace	To regulate the safety, health and environment at workplace	Department of Labour and Employment
20.	Building and Other construction workers (Regulation and the Employment and conditions of service) Act, 1996; Minimum Wages Act, 1948; Workmen's Compensation Act, 1923;	To regulate the employment and conditions of service of building and other construction workers and to	Department of Labour and Employment

Sl No.	Legislation	Objective	Responsible Institution
	The Contract Labour (Regulation & Abolition) Act, 1970 and Rules Employees State Insurance Act, 1948 (ESI); Minimum Wages Act, 1948, The Payment of Wages Act, 1936, amended in 2005; Maharashtra Labour Welfare Fund Act, 1953 (as amended) The Equal Remuneration Act 1976; Workmen's Compensation Act, 1923	provide for their safety, health and welfare measures	
21.	Interstate Migrant Workers Act 1979	In case workers and labourers working at the project sites are migrants from other states during construction	Department of Labour and Employment
22.	Child Labour (Prohibition and Regulation) Act, 1986	To regulate the employment of children including age limits, type of employment, timing of work, information disclosure and health and safety	Department of Labour and Employment

2.1.4 Required Clearances/Permissions

26. As per GoI EIA Notification 2006, all railways projects in India are exempted from Environmental Clearance (EC), this is applicable for Corridor 4 as well. Chennai being a coastal city, Light House to Foreshore Road falls under the coastal areas CRZ II and CRZ IV-B prescribed in the CRZ Notification 2019 and requires CRZ clearance from TNCZMA.

27. Before the start of civil works for any section of Corridor 4, CMRL must obtain necessary clearances/permissions from statutory authorities. For implementation of Corridor 4, required clearances/ permissions related to environment, social and forests have been summarized in Table 2.2.

Table 2-2: Applicable Permissions and Clearances Required for Corridor 4

Sl. No	Permissions/ Clearances	Acts/Rules/Notification s/ Guidelines	Concerned Agency	Responsibility and Timeframe
A. Pre-construction Stage				
1.	Permission for felling of trees	Forest Conservation Act, 1980	CMDA	CMRL (3 - 6 months)
2.	CRZ clearance for CRZ II CRZ permission for CRZ IV-B	CRZ Notification, 2019	TNCZMA & MoEF&CC	CMRL (6 months)

Sl. No	Permissions/Clearances	Acts/Rules/Notification s/ Guidelines	Concerned Agency	Responsibility and Timeframe
3.	Permission of construction near the National Shrine of St. Thomas Basilica, Santhome High Road; Rosary Church, Rosary Church Road and Our Lady of Light Shrine, Luz Church Road, which are located within 100m from the alignment of Corridor 4	The Ancient Monuments and Archaeological Sites and Remains (Amendment) Bill, 2018 Annexure XXV, Special Rules for conservation of Heritage Buildings Vol II: Second Master Plan for Chennai Metropolitan Area 2026 amended May 2013	Member Secretary CMDA	Contractor and CMRL (3 - 6 months)
4.	Building Permissions for stations and depots	Second Master Plan for Chennai Metropolitan Area 2026 amended May 2013	CMDA	Contractor and CMRL (6 months)
B. Implementation Stage				
5.	Consent to Establish & Operate for Ready Mix Concrete plant & casting yard	Air (Prevention and Control of Pollution) Act 1981	TNPCB	Contractor engaged by CMRL To be obtained before installation
6.	Permission for withdrawal /dewatering of groundwater ⁹	Environment (Protection) Act, 1986 Chennai Metropolitan Area Groundwater (Regulation) Act, 1987 as amended till 2008 Guidelines/Criteria for evaluation of proposals/requests for ground water abstraction (With effect from 16.11.2015)	CGWA	Contractor engaged by CMRL To be obtained before construction (3 months)
7.	Consent to recharge groundwater with tunnel dewatering water	Water (Prevention and Control of Pollution) Act 1974 amended 1988, Environment (Protection) Amendment Rules, 2017 (Discharge Standard for Sewage Treatment Plants (STPs)), Model Groundwater (Control	CGWB/PW D	Contractor engaged by CMRL To be obtained before construction (3 months)

⁹ The Contractor will avoid extraction of groundwater as much as possible. If not avoidable, the permission will be obtained prior to the extraction.

Sl. No	Permissions/Clearances	Acts/Rules/Notification s/ Guidelines	Concerned Agency	Responsibility and Timeframe
		and Regulation) Bill 1970, amended in 1972, 1996 and 2005		
8.	Authorization for storage (diesel) and disposal of Hazardous Waste	Hazardous and Other Wastes (Management & Transboundary Movement) Amendment Rules, 2019	TNPCB	Contractor engaged by CMRL To be obtained before installation (3 months)
9.	Consent for disposal of sewage from labour camps.	Water (Prevention and Control of Pollution) Act 1974 amended 1988 Environment (Protection) Amendment Rules, 2017 (Discharge Standard for STPs)	TNPCB	Contractor engaged by CMRL To be obtained before installation (3 months)
10.	Pollution Under Control Certificate for various vehicles use for construction	Central Motor and Vehicle Act, 1988	Transport Commissioner State Transport Authority, GoTN authorised testing centres	Contractor engaged by CMRL To be obtained before installation (3 months)
11.	Employing Labour/ workers	The Building and Other Construction Workers (Regulation of Employment and Conditions of Service) Act, 1996	District Labour Commissioner	Contractor engaged by CMRL To be obtained before installation (1 month)
12.	Roof Top Rainwater Harvesting (RWH)	Central Groundwater Authority (CGWA) Guidelines and Chennai Metropolitan Water Supply and Sewerage Board (CMWSSB)	CGWA / CMWSSB	Contractor engaged by CMRL To be obtained before installation (3 months)
13.	Permission for use of fresh water for construction and drinking purpose.	Environment (Protection) Act, 1986	Municipal Corporation	Contractor engaged by CMRL To be obtained before installation (3 months)
14.	Permission for Quarry Operation	The Mines and Minerals (Development and Regulation) Act, 1957	State Department of Mines and Geology	Contractor engaged by CMRL To be obtained before construction (2 – 6 months)

Sl. No	Permissions/Clearances	Acts/Rules/Notification s/ Guidelines	Concerned Agency	Responsibility and Timeframe
15.	Authorization for Disposal of Construction and Demolition Waste	Construction and Demolition Waste Management Rules, 2016	TNPCB	Contractor engaged by CMRL To be obtained before installation (2 months)
16.	Heritage Assets (St. Thomas Basilica, Rosary Church and Our Lady of Light Shrine)	Annexure XXV, Special Rules for conservation of Heritage Buildings Vol II: Second Master Plan for Chennai Metropolitan Area 2026 amended May 2013	CMDA	Contractor engaged by CMRL To be obtained before construction (2 months)
17.	Consent to Establish labour camps, pre-casting and material yards, hot mix plant, crushers, batching plant, stations, depots	Air, Water and Noise Regulations	TNPCB	Contractor engaged by CMRL To be obtained before installation The Application forms for seeking Consent are available from the office of TNPCB at Chennai. (3 months)
18.	Consent to muck/waste disposal	Construction and Demolition Waste Management Rules, 2016 Solid Waste Management Rules, 2016	TNPCB	Contractor engaged by CMRL To be obtained before installation (2 months)
19.	Consent to Operate Depot and Compliance with discharge norms of wastewater	Water (Prevention and Control of Pollution) Act 1974 amended 1988; The Tamil Nadu Water (Prevention and Control of Pollution) Rules, 1983 amended May 2009; Environment (Protection) Amendment Rules, 2017 (Discharge Standard for Sewage Treatment Plants(STPs))	TNPCB	CMRL (3 months)
20.	Installation and operation of DG sets at stations and depots	Air (Prevention and Control of Pollution) Act, 1981 amended 1987; CPCB Notification April 1994 of National Ambient Air Quality Standards	TNPCB	CMRL (2 months)

2.1.5 Institutional Administrative Framework

28. The administrative framework in India for implementation and monitoring of Metro Rail Projects involves following key agencies.

29. **Ministry of Environment, Forests and Climate Change (MoEF&CC):** MoEF&CC is apex body in India responsible for protection and enforcement of laws and regulations. In view of the growing importance of environmental affairs, the Government of India set up a Department in November 1980 under the portfolio of the Prime Minister. The department later renamed as the MoEF&CC plays a vital role in environmental management for sustained development and for all environmental matters in the country.

30. The major responsibilities of MoEF&CC includes, Environmental resource conservation and protection, Environmental Impact Assessment of developmental projects, Co-ordination with the other ministries and agencies, voluntary organizations and professional bodies on environmental action plans, Policy-planning, Promotion of research and development, manpower planning and training and creation of environmental awareness; Liaison and coordination with international agencies involved in environmental matters.

31. Developmental project proponents are also required to submit Environmental Impact Statements/Assessments to establish that preventive measures are planned by installing adequate pollution control and monitoring equipment, and that effluent discharged into the environment will not exceed permissible levels. The MoEF&CC appraises these statements/ assessments and approves the project from the environmental angle.

32. **Tamil Nadu State Pollution Control Board (TNPCB):** Tamil Nadu Pollution Control Board was formed under the provisions of section 4 of Water (Prevention & Control of Pollution) Act, 1974. The Board is also functioning as the State Board under section 5 of the Air (Prevention & Control of Pollution) Act, 1981. The prime objective of all these Acts is maintaining, restoring and preserving the wholesomeness of quality of environment and prevention of hazards to human beings and terrestrial flora and fauna.

33. **Central Ground Water Board (CGWB):** The CGWB is responsible for the development, dissemination of technologies, and monitoring of India's groundwater resources, including their exploration, assessment, conservation, augmentation, protection from pollution and distribution. The CGWB, under the Ministry of Water Resources, was established in 1970. Various activities related to regulation and control of groundwater development in the country is the responsibility of the Central Ground Water Authority (CGWA) specifically constituted under the Environmental (Protection) Act, 1986. The CGWA has identified over exploited-areas across India where groundwater withdrawal is regulated. To date, 43 critical/ overexploited notified areas have been identified in 10 states. Construction of new ground water structures is prohibited in the notified areas while permission of drilling tube wells is being granted only to the government agencies responsible for drinking water supply.

34. **The National Green Tribunal (NGT):** NGT has been established on 18.10.2010 under the National Green Tribunal Act 2010 for effective and expeditious disposal of cases relating to environmental protection and conservation of forests and other natural resources including enforcement of any legal right relating to environment and giving relief and compensation for damages to persons and property and for matters connected therewith or incidental thereto. It is a specialized body equipped with the necessary expertise to handle environmental disputes involving multi-disciplinary issues. The Tribunal shall not be bound by the procedure laid down under the Code of Civil Procedure, 1908, but shall be guided by principles of natural justice.

35. The Tribunal's dedicated jurisdiction in environmental matters shall provide speedy environmental justice and help reduce the burden of litigation in the higher courts. The Tribunal is mandated to make and endeavour for disposal of applications or appeals finally within 6 months of filing of the same. Initially, the NGT is proposed to be set up at five places of sittings and will follow circuit procedure for making itself more accessible. New Delhi is the Principal Place of Sitting of the Tribunal and Bhopal, Pune, Kolkata and Chennai shall be the other four place of sitting of the Tribunal.

2.2 International and Regional Agreements and Conventions

36. India is member of almost all major Multilateral Environmental Agreements (MEAs), under four clusters, namely the following:

- A. Nature conservation;
- B. Hazardous material;
- C. Atmospheric emissions; and
- D. Marine environment.

37. The Nature conservation and Climate change agreements will be applicable to this Corridor.

A. Nature conservation

No.	Nature Conservation
1	Ramsar Convention on Wetlands
2	CITES (Convention on International Trade in Endangered Species of Fauna and Flora)
3	TRAFFIC (The Wildlife Trade Monitoring Network)
4	CMS (Convention on the Conservation of Migratory Species)
5	CAWT (Coalition Against Wildlife Trafficking)
6	CBD (Convention on Biological Diversity)
7	ITTC (International Tropical Timber Organisation)
8	UNFF (United Nations Forum on Forests)
9	IUCN (International Union for Conservation of Nature and Natural Resources)
10	GTF (Global Tiger Forum)

B. Hazardous material

No.	Hazardous material
1	Cartagena Protocol on Biosafety
2	SAICM (Strategic Approach to International Chemicals Management)
3	Stockholm Convention on Persistent Organic Pollutants (POPs)
4	Basel Convention on the Control of Trans-boundary Movement of Hazardous Waste and Their Disposal
5	Rotterdam Convention on Prior Informed Consent (PIC) for certain Hazardous Chemicals and Pesticides in International Trade

C. Atmospheric emissions

No.	Atmospheric emissions
1	UNFCCC (United Nations Framework Convention on Climate Change)
2	Kyoto Protocol
3	UNCCD (United Nations Convention to Combat Desertification)
4	Montreal Protocol (on Ozone Depleting Substances)

D. Marine environment

No.	Marine environment
-----	--------------------

1	IWC (International Whaling Commission)
---	--

2.3 MDBs' Requirements Applicable to the Project

38. MDBs' project planning activities related to environmental and social safeguards generally comprise, a) screening and categorization by Bank; b) due diligence of the project by Bank; c) environmental and social assessment by Borrower and its review by Bank; d) information disclosure by Borrower and Bank and consultation by Borrower; e) monitoring and reporting by Borrower and Bank; and f) grievances.

2.3.1 Safeguard Policy Statement (SPS) 2009 of ADB

39. ADB's SPS 2009 sets out the policy objectives, scope and triggers, and principles for three key safeguard areas:

- i. Environmental Safeguards,
- ii. Involuntary Resettlement Safeguards, and
- iii. Indigenous Peoples Safeguards.

2.3.2 Environmental and Social Framework (ESF) 2019 of AIIB

40. ESF of AIIB comprises the following:

- i. **Environmental and Social Policy (ESP).** This comprises mandatory environmental and social requirements for each Project
- ii. **Environmental and Social Standards.** Three associated mandatory environmental and social standards (ESSs) set out more detailed environmental and social requirements relating to the following:
 - ESS 1: Environmental and Social Assessment and Management;
 - ESS 2: Involuntary Resettlement; and
 - ESS 3: Indigenous Peoples.

2.3.3 Environment and Social Framework (ESF) 2016 of NDB

41. ESF of NDB comprises the Environmental and Social Policy and three Environment and Social Standards:

- ESS 1: Environment and Social Assessment: Screening, impact assessment, alternatives, management plan, consultations, grievance mechanism, information disclosure, monitoring.
- ESS 2: Involuntary Resettlement'
- ESS 3: Indigenous Peoples.

2.4 Applied Standards

42. The project will follow national as well as international best practices and standards related to environment, health and safety including IFC/WB Environmental, Health, and Safety (EHS) General Guidelines (April 30, 2007), whichever is stringent.

3. PROJECT DESCRIPTION

3.1 Rationale

43. India has experienced rapid growth in urbanization over several decades, with the share of the urban population from 17.9 percent in 1960 to 34.0 percent in 2018.¹⁰ By 2030, Indian cities are projected to be home to another 250 million people.¹¹ High-technology and export-oriented manufacturing jobs are growing fastest in the outskirts of large metropolitan areas. The metropolitan areas are facing extremely high population densities and traffic congestion. Infrastructure development remains key to plan urban development taking into consideration economic activities, mobility, and environmental and social outcomes.

44. Gol has made efforts to reform the transport sector in recent years. To create safe, affordable, quick, comfortable, reliable, and sustainable urban transport systems for Indian cities, the Ministry of Urban Development (MoUD) formulated the National Urban Transport Policy (NUTP) in 2006. The NUTP proposes the development of a metro rail system in every city of India with a population of more than two million people. Gol's Union Cabinet approved a new Metro Rail Policy in 2017 that aims to enable the development and implementation of metro projects in a comprehensive and sustainable manner from the social, economic, and environmental perspectives. As of February 2019, metro line services with a total length of 585 km are operational in India.¹²

45. Chennai, the capital city of the state of Tamil Nadu, is part of the CMA playing a vital role in the economy of South India. The CMDA devised the Chennai Second Master Plan 2026 and estimated that the population and daily passenger traffic would grow to 12.6 million people and 20.8 million in 2026, respectively.¹³ CMA has emerged as a leading national automotive hub with major manufacturers operating their plants in the area. CMA also houses a growing number of software firms, financial services, and call centres. Like other metropolitan areas in the country, CMA is currently facing the challenges of accelerated urbanization growth that have considerably strained the area's transportation system. The increase in economic activities has boosted the regional economy and job creation, which in turn necessitates improvement in ease of travel and connectivity.

46. The existing transportation system in CMA is marked by high traffic density, carbon emissions, and frequent road incidents. In addition to the high volume of vehicles and already congested roads, inadequate parking space and the encroachment of street space by vendors on major road have exacerbated the traffic congestion. The accelerating use of private vehicles has put Chennai in the fifth rank in carbon emission from the transport sector among 54 South Asian cities.¹⁴ Chennai also recorded the highest number of road incidents in India, with a staggering 7,846 cases in 2016.¹⁵

47. CMRL, a joint venture of the Gol and GoTN with equal equity ownership, is responsible for implementing, operating, and maintaining the city's metro system. CMRL developed The Comprehensive Mobility Plan for CMA in 2015 to identify the present and future mobility patterns of CMA. The detailed study identified three corridors (corridors 3, 4, and 5) for the second phase of the Chennai Metro Rail to alleviate CMA's transportation capacity constraints.

¹⁰<https://data.worldbank.org/indicator/SP.URB.TOTL.IN.ZS?locations=IN>

¹¹ Urbanization Beyond Municipal Borders, The World Bank, 2013.

¹² Press Information Bureau, Ministry of Housing and Urban Affairs, Government of India,

¹³ Second Master Plan for Chennai Metropolitan Area 2026, Chennai Metropolitan Development Authority, 2008.

¹⁴ International Council for Local Environmental Initiative Study, 2012.

¹⁵ Accidental Death and Suicides in India (ADSI), National Crime Records Bureau, 2016.

3.2 Description of the Corridor 4

48. The first phase of the Chennai Metro Rail covers 54 km in two corridors, with 45 km currently already in operations since 2015 and another 9 km to be operational in 2020. GoI, GoTN, and the Japan International Cooperation Agency (JICA) funded the first phase that provides direct connection between northern and southern parts of Chennai.

49. The Chennai Metro Corridor 4 from Lighthouse to Poonamallee Bypass has a length of 25.8 km, of which 15.8 km is elevated, and 10.0 km is underground, with 18 and 9 stations, respectively. Stations of Corridor 4 are depicted in Figure 3.1 and summarized in Table 3.1.

Figure 3-1: Corridor 4 (Updated April 2021)

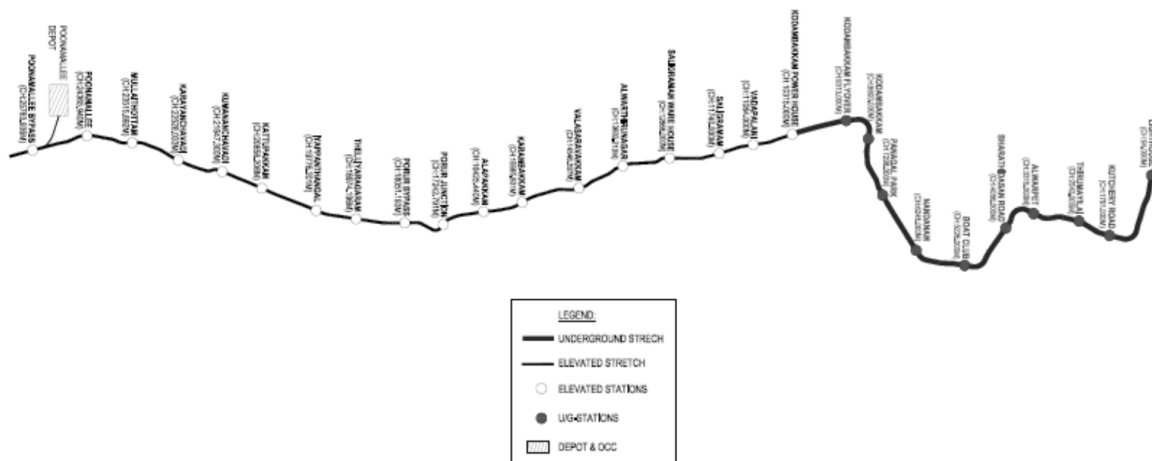

Table 3-1: List of Stations –Corridor 4

No	Station Name	Chainage (m)	Inter-station Distance(m)	Elevated/ Underground
1	Lighthouse	94.000	-	UG (190x21.80) 2L
2	Kutchery Road	1791.000	1697.000	UG (190x21.80) 2L
	Thirumayilai Metro (in Corridor 3)	2543.000	752.000	UG (190x21.80) 2L
3	Alwarpet	3315.000	772.000	UG (190x21.80) 2L
4	Bharathidasan Road	4058.000	743.000	UG (190x21.80) 2L
5	Boat Club Metro (formerly Adyar Gate Junction)	5226.000	1168.000	UG (150x21.40) 3L
6	Nandanam	6245.000	1019.000	UG (150x21.40) ML
7	Panagal Park	7296.000	1051.000	UG (150x21.40)
8	Kodambakkam Metro	8600.000	1304.000	UG (150x21.40) ML
9	Kodambakkam Flyover (formerly Meenakshi College)	9313.000	713.000	UG (190x21.80) 2L
10	Power House	10315.000	1002.000	Elevated (140x21.95)
11	Vadapalani	11064.000	749.000	Elevated (140x21.95)
12	Saligramam	11740.000	676.000	Elevated (140x21.95)

No	Station Name	Chainage (m)	Inter-station Distance(m)	Elevated/ Underground
13	Saligramam Warehouse (formerly Avichi School)	12666.000	926.000	Elevated (140x21.95)
14	Alwarthiru Nagar	13602.213	936.213	Elevated (140x21.95)
15	Valasaravakkam	14546.387	944.174	Elevated (140x21.95)
16	Karabakkam	15685.801	1139.414	Elevated (140x21.95)
17	Alapakkam Junction	16425.440	739.639	Elevated (140x21.95)
18	Porur Junction	17242.790	817.350	Elevated (140x21.95)
19	Chennai Bypass Crossing	18051.190	808.400	Elevated (140x21.95)
20	Ramchandra Hospital	18974.196	923.006	Elevated (140x21.95)
21	Iyappanthangal Bus Depot.,	19776.201	802.005	Elevated (140x21.95)
22	Kattupakkam	20858.200	1081.999	Elevated (140x21.95)
23	Kumanan Chavadi	21647.300	789.100	Elevated (140x21.95)
24	Karyan Chavadi	22558.030	910.730	Elevated (140x21.95)
25	Mullaithottam	23515.892	957.862	Elevated (140x21.95)
26	Poonamallee Metro (formerly Poonamallee Bus Terminus)	24365.94	850.048	Elevated (140x21.95)
27	Poonamallee Bypass	25783.936	1417.996	Elevated (140x21.95)

3.2.1 Land Use

50. Land use along the alignment is summarised in Table 3.2.

Table 3-2: Land use abutting the Alignment

Corridor	Section / Station	Land Use
Lighthouse to Poonamallee bypass	Lighthouse	Institutional + Open Space Reservation along seafront on either side *
	Santhome Church	Institutional
	Lighthouse to Kutchery Road	CRZ II and IV-B
	Nandanam to Panagal Park	Commercial + Residential * ^
	Meenakshi college	Institutional + Residential *
	Powerhouse to Vadapalani	Commercial + Residential on either side * ^
	Porur lake	Water body *
	Ramachandra Hospital	Institutional + Residential on either side *

* Figure 4.4 Land use in CMA 2006, Master Plan 2026

@ Ecologically Sensitive Areas in CMA, Master Plan 2026

^ Land use away from alignment is residential

51. Topographical survey was carried out in detail using modern surveying instruments. The geotechnical investigations determined the required strength characteristics of the underlying soil/rock strata to design the foundation of the proposed structure. A total of 52 bore holes were drilled all along the proposed Corridor 4 alignment. Also, since the

proposed site is located in seismic Zone III of India, suitable seismic measures will be adopted in the design of the structures.

3.2.2 Salient Design Features

52. The salient features of Corridor 4 Project are summarized in Table 3.3.

Table 3-3: Salient Features of Chennai Metro Corridor 4

Gauge(Nominal):	1435 MM
Route Length:	25.8km (10.0 km Underground and 15.8 km Elevated)
Number of Stations:	30 (9 Underground and 18 Elevated)
Speed:	
1. Design Speed	80 kmph
2. Maximum Design Speed	90 kmph
3. Schedule(Booked)Speed	32 kmph

Train Operation Plan:

Particulars	2025	2035	2045	2055
Trains/hour (3 Car, 6 Car)	13 (13,0)	13 (6,7)	14 (3,11)	15 (0,15)
Head Way (Second)	277	277	257	240
Capacity (6p/m ² ;8p/m ²)	9,958;12,675	15,628;19,878	19,634;24,969	23,640;30,060
Max. PHPDT Demand	11,707	18,944	23,816	29,940
Total Coach Requirement	78	129	156	186

Traction Power Supply:

1. Traction System Voltage 25 kV AC
2. Current Collection Overhead Electric Traction
3. Receiving Substations Two RSSs at Avichi School and Panagal Park stations (RSSs)

Power Demand (MVA):

Load	2025		2035		2045		2055	
	Normal	Emergency	Normal	Emergency	Normal	Emergency	Normal	Emergency
3km from Kilpauk GSS-Panagal Park RSS (Chainage -255 to 7436) 7.691km								
Traction	2.45	8.39	3.62	12.41	4.40	15.10	5.36	18.38
Auxiliary	11.67	19.95	14.58	24.40	16.32	27.46	17.49	29.62
Total	14.12	28.34	18.20	36.81	20.72	42.56	22.85	48.00
3.5 km from Koyambedu GSS-Avichi School RSS (Chainage -7436 to 25829) 18.38km								
Traction	5.94	8.39	8.79	12.41	10.70	15.10	13.02	18.38
Auxiliary	8.28	19.95	9.82	24.40	11.14	27.46	12.13	29.62
Total	14.22	28.34	18.61	36.81	21.84	42.56	25.15	48.00

Rolling Stock:

1. Rolling Stock with light weight Stainless Steel/Aluminum Body
2. Max. Axle Load 16 T
3. Dimensions L22.6 x W2.9m x H3.9m

Maintenance Facilities:

Maintenance depot has been proposed near Poonamallee Bypass station for 31 rakes of 6 cars for washing, maintenance and repairs of the rolling stock operation.

Signalling, Telecommunication and Train Control:

1. Type of signalling Communication based Train Control System (CBTC) with unattended train operation permitting an operational headway of 90 seconds.
2. Telecommunication Integrated System with Optic Fiber cable, Supervisory Control and Data Acquisition (SCADA), Close Circuit Television (CCTV), Central Voice Recording System (CVRS) etc.

Fare Collection:

Automatic Fare Collection (AFC) System with smart card/token etc.

3.2.3 Station Design

53. Elevated stations located at the median of existing roads will be 140 m long and 24 m wide. The stations will be constructed using the cantilever method. The typical elevated station consists of three levels: ground, concourse and platform. Passenger facilities, operational and commercial areas are provided at the concourse level. Platforms will be at a level of 13 m and concourse floor at about 7 m above the road, with a minimum of 5.5 m of vertical clearance under the concourse. To reduce physical and visual impact, stations will be transparent with minimum walls on the sides. Figure 3.2 shows the typical elevated station.

Figure 3-2: Typical Elevated Station

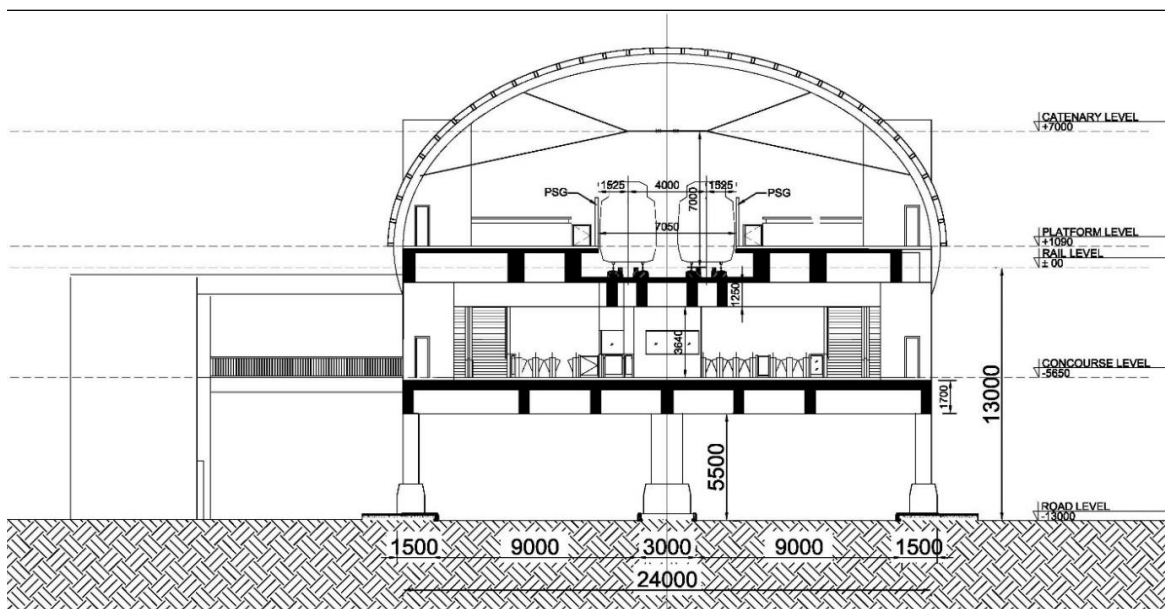

Source: Detailed Project Report for Chennai Metro Rail Phase II corridors, February 2017

54. The typical underground station is a two- or three-level station with entrances at ground level, a concourse with ticketing and passenger area, and platforms at the lowest level. Platforms will 140 m long and 12 m wide with easy accessibility features including escalators and elevators. Universal accessibility and green building features will be considered in the design. Two end concourses have been proposed, one at each end. The concourse is divided into paid and unpaid area. Since very limited space is available on the

ground at station, all the over-ground structures are therefore, planned as and where space is available and are not necessarily grouped at ground level. The stations will be constructed using the cut and cover method. Figure 3.3 shows the typical underground station.

Figure 3-3: Typical Underground Station (2-level)

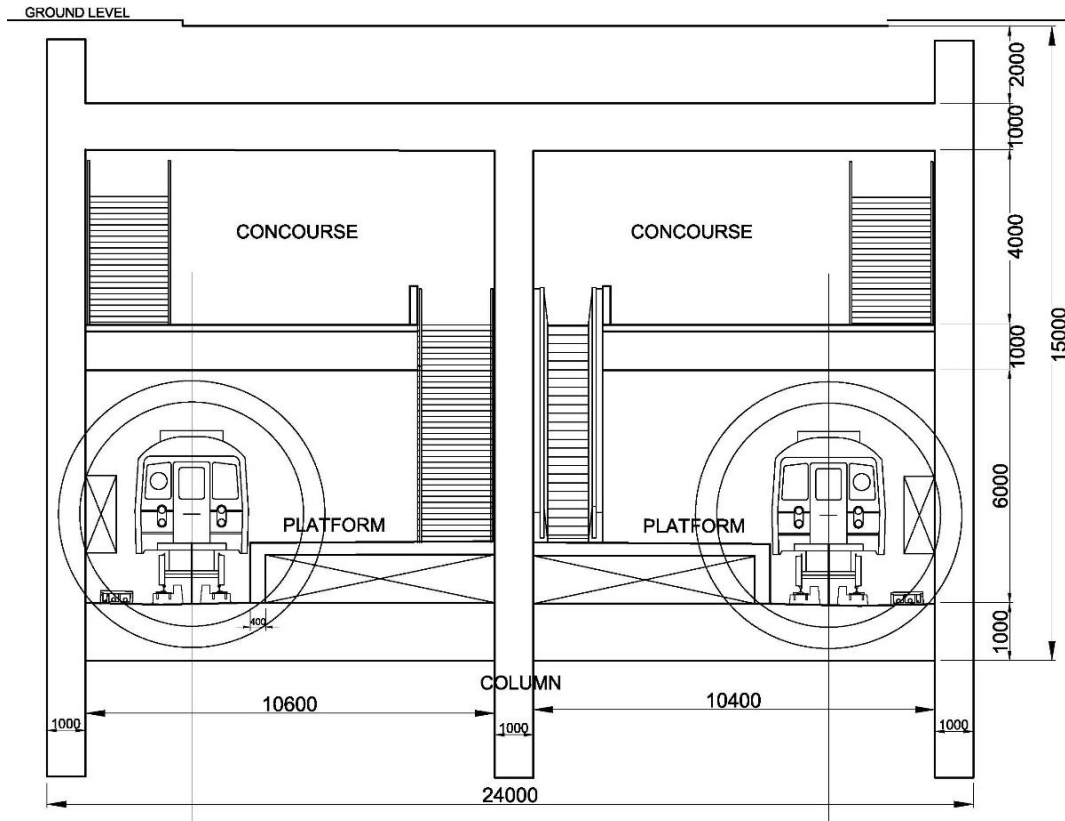

Source: Detailed Project Report for Chennai Metro Rail Phase II corridors, February 2017

3.2.4 Ventilation and Air-Conditioning System

55. The underground stations of the corridor are built in a confined space. A large number of passengers occupy concourse halls and the platforms, especially at the peak hours. The platform and concourse areas do not have adequate natural ventilation. It is therefore, essential to provide forced ventilation in the stations and inside the tunnel for the purpose of:

- Supplying fresh air for the physiological needs of passengers and the staff
- Removing body heat, obnoxious odours and harmful gases
- Removing large quantity of heat dissipated by the train equipment/fixtures
- Removing fumes and heat emitted by station equipment/fixtures

56. The tunnel ventilation shaft will be provided at each end of the station vertically from ground to concourse or platform level.

3.2.5 Depot

57. Major maintenance depot is proposed at Poonamallee Bypass. The depot comprises automatic coach washing plant, Operations Control Centre, maintenance infrastructure viz stabling lines, scheduled inspection lines, workshop for overhaul, unscheduled maintenance for the rolling stock and maintenance facilities for Civil – track,

buildings, water supply; electrical – traction, E&M; signaling & telecommunication; automatic fare collection etc. Figure 3.4 shows the layout plan of Poonamallee Depot, which is proposed to have the following functions:

- Major overhauls of all the trains.
- All minor schedules and repairs.
- Lifting for replacement of heavy equipment and testing thereafter.
- Repair of heavy equipment.

Figure 3-4: Layout Plan of Poonamallee Depot



3.2.6 Labour Camp

58. The Contractor during the progress of work, will provide, erect and maintain necessary (temporary) living accommodation and ancillary facilities for labour. Contractor will establish construction camps as part of the project. Emphasis will be given to use existing facilities (established under ongoing lines). However, locations of the camps will be finalized after mobilization of contractor and in consultation with CMRL. The Contractor engaged by CMRL will also coordinate with the development authority for land use clearance, TNPCB and Municipal Corporation to establish the labour camps before construction.

3.2.7 Construction Activities and Methodology

59. Main construction activities include demolition of structures and ground clearing; Excavation and fill; Tunneling; Transport of construction materials, muck and waste; Casting of concrete elements and preparation of concrete and their transportation; Pile driving where cast-in-situ is not feasible, blasting in rock etc.

60. Elevated Sections. Substructure - open foundation, pile, pile caps, columns; station structure; earth retaining structures shall be cast-in-situ. The structural elements for superstructure i.e. box segments, I-Girders, U-girders and sometimes pile caps are pre-cast. Pre-cast construction may be segmental or non-segmental type. In case of segmental method, structural segments are pre-casted in casting yards, pre-stressed and then transported to the location of use and launched by means of suitable launching arrangement. The construction yard has arrangement for casting beds, curing and stacking area, batching plant with storage facilities for aggregates and cement, site testing

laboratories, reinforcement steel yard and fabrication yard etc. An area of about 3 ha is required for each construction yard.

61. **Underground Sections.** Usually sections between underground stations are constructed by tunneling using Tunnel Boring Machine (TBM) while underground stations are built by cut-and-cover method. In the latter method, sidewalls of excavation at stations are supported in various ways. Between two stations tunnel is constructed by TBM. It will be launched from launching shaft. It is dragged in station area and continues from other side of station. Ground settlement analysis and monitoring is required during tunneling by TBM. Two separate tunnels are constructed by two different TBM. The initial plan is one to enter at Lighthouse Station, exit at Bharathidasan Road and the other one to enter at Natesan Park and exit at Bharathidasan Road and Meenakshi College. Depending upon the soil/rock strata, suitable type of TBM shall be used for tunneling. Locations where deployment of TBM is not possible (tunneling of short length, cross passages, underground stations which are not possible by cut and cover method etc.) are tackled by New Austrian Tunneling Method (NATM).

62. The typical viaduct and tunnel are shown in Figure 3.5 and 3.6.

Figure 3-5: Typical superstructure of viaduct

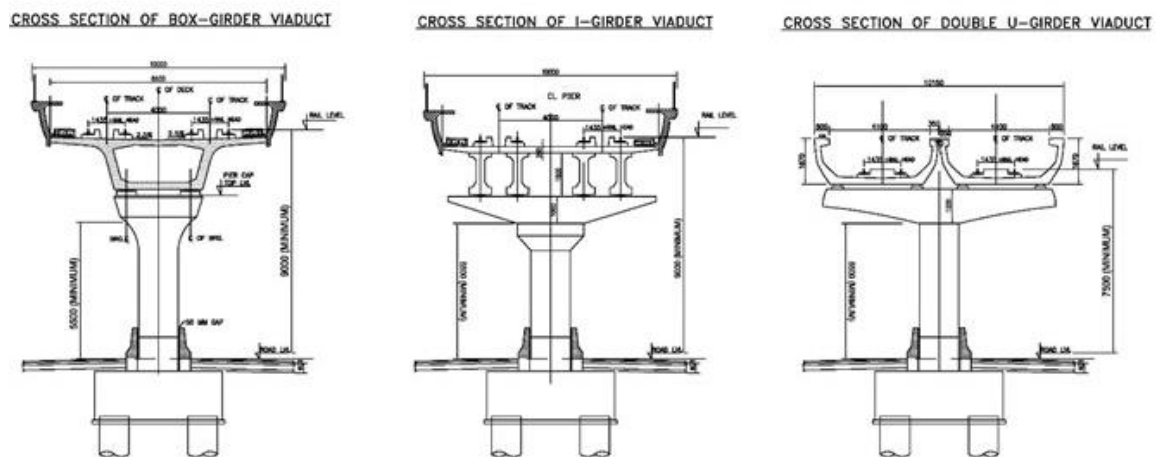

Source: Detailed Project Report for Chennai Metro Rail Phase II corridors, February 2017

Figure 3-6: Typical Twin Tunnel Section

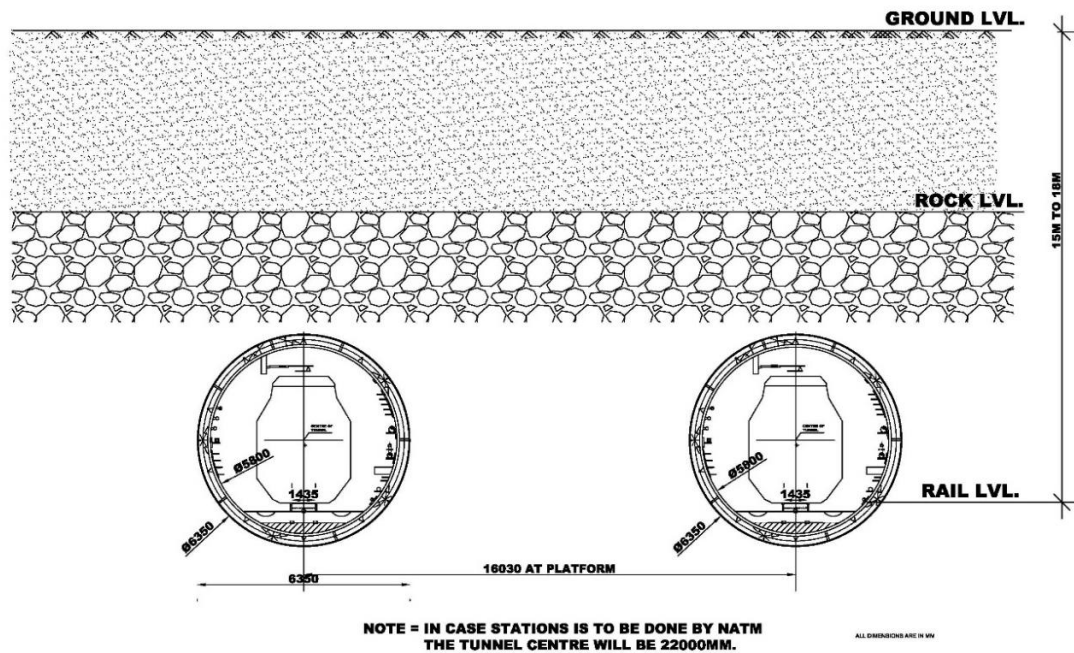

Source: Detailed Project Report for Chennai Metro Rail Phase II corridors, February 2017

3.3 Associated Facilities

63. Associated facilities are those that are not included or funded by the Project but are: (i) directly and materially related to the Project; (ii) carried out or planned to be carried out, contemporaneously with the Project; and (iii) necessary for the Project to be viable and would not be constructed or expanded if the Project did not exist.

64. Potential Associated facilities for Corridor 4 are the power transmission/distribution system, existing grid substations (GSS) and water supply network. The construction and operation of Corridor 4 will require power and water from existing electricity grid and water supply system. Electricity is required for operation of Metro system for running of trains, station services (e.g. lighting, lifts, escalators, signaling & telecom, firefighting etc. and workshops, depots & other maintenance infrastructure within premises of metro system). The power requirements of a metro system are determined by peak-hour demands of power for traction and auxiliary applications. These existing grid substations and water supply network are being operated and managed by respective agencies under full compliance with state and local policies and regulatory frameworks.

65. AIIB counts all co-financiers' components as one Project, hence, associated facility is not triggered in this EIA and in AIIB's legal documents

66. In accordance with proposed packaging of Corridor 4, underground stretch, elevated stretch and depot will be financed by different MDB and do not constitute Associated Facilities. Nevertheless, the environmental impacts and mitigation measures of all packages are analyzed in this report.

3.4 Implementation Plan, Schedule and Cost

67. Corridor 4 will be implemented under design consultant and civil work contracts. There will be several packages for different components such as civil works contracts, detailed design, system contracts, supply and installations, rolling stocks etc. It is estimated that project will be constructed over a period of 6 years. The operation is expected to start by 2026. Figure 3.7 shows the detailed schedule. The total capital cost of Corridor 4 is estimated to cost USD2.17 billion.

4. ENVIRONMENTAL BASELINE

68. The collection of current baseline information on physical, ambient, ecological and socioeconomic environment of the project area of influence, provides an important reference for conducting an EIA. The description of environmental settings includes the characteristic of area in which the project activities would occur and likely to be affected by project related impacts. Compiled existing baseline conditions include primary data on air quality, water quality, noise, soil, ecology and biodiversity, and socioeconomic aspects. Secondary data were also collected from published source and various government agencies.

4.1 Data Collection Methodology

69. The data on water, air, and noise were collected through field monitoring conducted in July 2016 and May 2017. The noise and vibration data were further elaborated in 2019 to include the sensitive receptors along the Corridor 4. Data on biodiversity was collected through the field studies in May 2018. Meteorological data was collected from India Meteorological Department (IMD). Efforts have been made to compile the available data from literature, books, maps and reports. The methodology adopted for data collection is highlighted wherever necessary. Environmental attributes and samplings of baseline surveys are presented in Table 4.1 and monitoring locations are presented in Table 4.2 and Figure 4.2. The detailed analysis reports received from the monitoring laboratory are provided in **Annexure 1**, whereas summary from the reports are discussed in respective sections.

Table 4-1: Environmental Attributes and Data Source

Sl. No	Attribute	Parameter	No. of Samples	Source
Physical Environment				
1.	Geology	Geological Status	---	Literature review
2.	Seismology	Seismic Hazard	---	Literature review
3.	Climate	Climate Parameters	---	Literature review
4.	Soil Quality	Physico-chemical parameters	9	Sampling/ Monitoring locations
Ambient Environment				
5.	Water Quality	Physical, Chemical and Biological parameters	8 (Groundwater) 1 (Surface)	Sampling/ Monitoring locations
6.	Ambient Air Quality	PM, SO ₂ , NO ₂ and CO	8	Sampling/ Monitoring locations
7.	Noise	Noise levels in dB (A) L _{max} , L _{min} , L _{eq} , L ₁₀ , L ₅₀ , L ₉₀	30 (Sample Sensitive Receptors)	Sampling/ Monitoring locations
8.	Vibration	Peak Particle Velocity in mm/s	13 (Sample Sensitive Receptors)	Sampling/ Monitoring locations
Ecological Environment				
9.	Trees	Number	Once	Field Studies/ Reconnaissance survey
Socio-Economic Environment				
10.	Socio-economic aspects	Socio-economic profile	Once	Field Studies by Social Team, Literature review.

Table 4-2: Details of Sampling / Monitoring Locations*

S. No	Distance from the Sampling Locations to the Alignment (A: Air, W: Water; S: Soil, N: Noise)	Land Use**
4A	At Crossing of NH 4 Bypass & Poonamallee Flyover, 23m (A, W, S, N)	Commercial
4B	Near Kumunan chavadi Bus Stop, MSS Nagar 15m (A, W, S, N)	Residential
4C	Near Porur Lake, Padmavati Nagar, 27m (A, W, S, N)	Residential
5C***	Alwarthiru Nagar junction (A, W, S, N)	Residential
4D	Permal Street, Shradha Nagar, 16m (A, W, S, N)	Residential
4E	Vadapalani Junction, 54m (A, W, S, N)	Commercial
4F	Kodambakkam Meenakshi College, 75m (A, W, S, N)	Silence Zone
4G	Santhome Church, 36m (A, W, S, N)	Silence Zone
4H	Porur Lake (water & soil only), 58m (W, S)	Water body

*Locations for noise and vibration at sensitive receptors are listed under Table 4.17 and Table 4.19 respectively.

**As per CPCB guideline which is presented under Noise Section.

***This sampling location is the shared alignment of Corridor 4 & 5.

70. Sampling locations were selected to represent land uses along the alignment namely commercial, residential and silence zone (religious and educational uses). The baseline information is categorized as physical, ambient, ecological and socioeconomic environment with depiction in following sections.

71. A further 270 environmentally sensitive receptors located within 200m on either side of alignment as listed in **Annexure 2** have been identified from site reconnaissance, comprising educational centres, religious places, hospitals and courts of law. To elaborate the baseline, a full set of baseline of air, water (surface and ground), soil, noise and vibration will be collected prior to the construction commencement.

4.2 Physical Environment

4.2.1 Physiography

72. Chennai is located on the South-Eastern coast of India in the North-Eastern part of Tamil Nadu. It is situated on a flat coastal plain that's why it is also known as the Eastern Coastal Plains. The study area is lies between Latitude of 13° 10' N to 12° 49' N and Longitude of 80° 10' E to 80° 14' E. Chennai is a low-lying area and the land surface is almost flat. It rises slightly as the distance from the sea-

shore increases but the average elevation of the city is not more than 3 m above mean sea-level, while most of the localities are just at sea-level and drainage in such areas remains a serious problem. The topographical setting of project area is shown in Figure 4.1.

Figure 4-1: Topographical setting of Project Area

Figure 4-2: Monitoring Locations



Field Survey: July 2016/May 2017

26	Mercury	mg/kg	BDL	BDL	BDL	BDL	BDL	BDL	BDL	BDL	BDL	2
27	Cadmium as Cd	mg/kg	BDL	BDL	BDL	1.24	BDL	1.72	1.32	1.68	BDL	1
28	Molybdenum	mg/kg	BDL	BDL	BDL	0.60	BDL	0.69	0.76	0.80	BDL	5
29	Available Nitrogen	Kg/hect	140.86	146.54	172.50	199.97	158.40	304.51	269.61	308.12	189.80	-

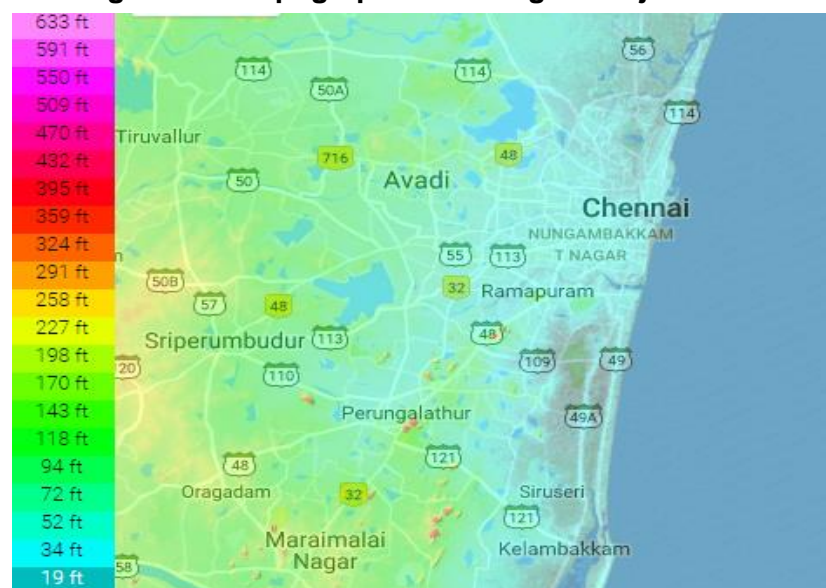
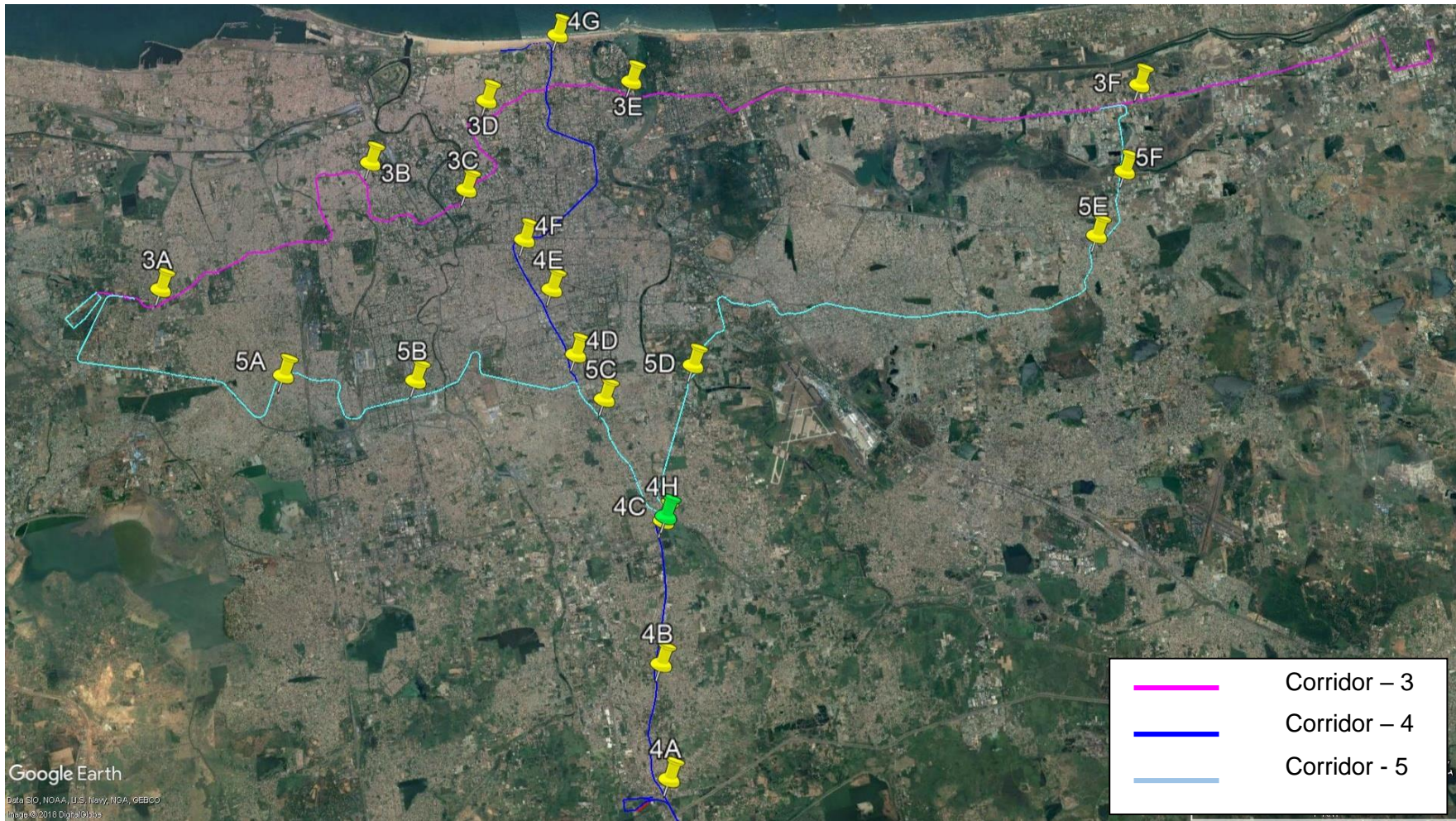
* As per Bureau of Indian Standards. The rest are as per ISO Soil Standards.

** As per the Geo-investigation report 2020, the Chloride as Cl ranges from 19.83 to 277.69 mg/kg.

4.2.2 Soil

73. The recent sandy soil (Entisols) is immature soils and is predominant in the city and it occurs in small patches. The major soil in this region belongs to Alfisols and Entisols. Inceptisols and Vertisols are found in a very limited area only. These soils are generally poor in soil nutrients. They have medium to high permeability. They have low water holding capacity except in patches of clayey soils. The laboratory analysis results for soil are reported in Table 4.3. The soils are slightly alkaline in nature. Organic matter content in soils varies from 0.57% to 1.26%. The soil types found along the alignments, as recorded in the Master Plan 2026 for CMA are presented in Table 4.4 and Figure 4.3, subject to more specific findings from geotechnical investigations.

Table 4-4: Soil Types along alignment

Corridor / Section	Type of soil
Corridor 4	
Lighthouse to Nandanam	Sandy
Nandanam to Porur	Clay
Porur to Poonamallee bypass	Sandy

Figure 4-3: Soil Types in CMA

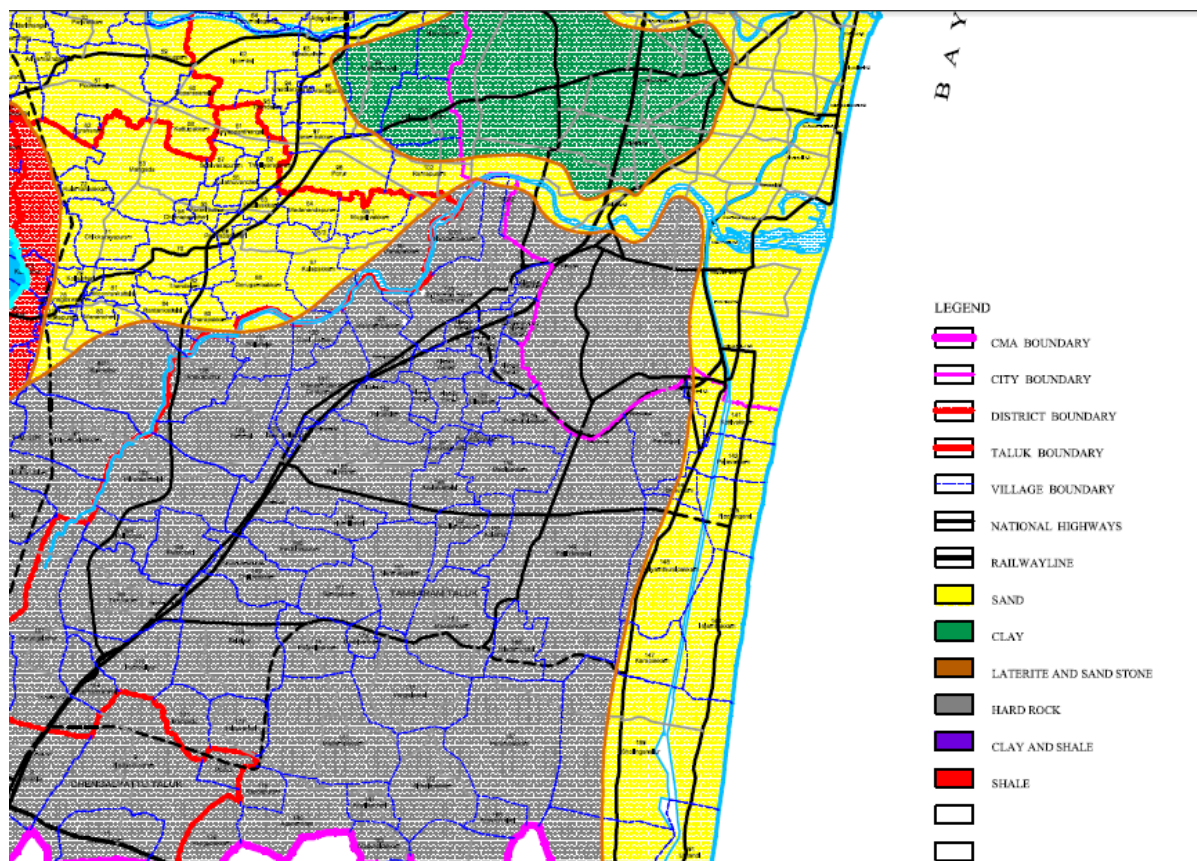

Second Master Plan for Chennai Metropolitan Area 2026, CMDA

74. The pH of the soil samples across all the sampling locations are observed to be alkaline. The conductivity of the soil is observed less than 1 mS/cm. The concentration of Zinc, Manganese, lead, copper, Nickel, Sulphur, Arsenic, Mercury, Cadmium (Cd) and Molybdenum are observed to be well within the limits (IS as well as ISO Soil standards). The recorded available Nitrogen has been observed within medium range (in comparison with soil rating

chart¹⁶) for samples collected at 4E, 4F and 4G, for other locations it is less than the stipulated limit of < 240Kg/ha.

4.2.3 Geology and Minerals

75. The geological formations in the region are from the Archaeans to the recent Alluvium (Table 4.5). The geological formations can be grouped into three units, namely (i) the Archaean crystalline rocks, (ii) consolidated Gondwana with Tertiary sediments and (iii) the recent Alluvium. Most of the geological formations are concealed by the alluvial materials, except for a few exposures of crystalline rocks like charnockites along the railway track in Guindy area. The thickness of Gondwana shales is highly variable in the city. It is more than 130 m at Porur and Koyembedu whereas it exceeds 25 m in Ashok Nagar and 60 m in Sterling Road. The highly variable nature of Gondwana sediments indicated the irregularly eroded crystalline basement, over which the Gondwana sediments are deposited.

Table 4-5: Geological Formation in the Project Area

Geological succession in Chennai district Group	System	Age	Lithology	Aquifer Characteristics
Quaternary	Recent	Sub-Recent	Soils, Alluvium (sand & silt)	Moderate to good porous aquifer system
Tertiary	(Cuddalore Sandstone equivalent)	Eocene to Pliocene	Sandstone & shale (fossiliferous)	Moderately Porous Aquifer
---UNCONFIRMITY---				
Mesozic	Upper Gondwana (Sri Perumbudur Beds)	Lower Cretaceous to Lower Jurassic	Brown Sandstone and siltstone; Grey shale; Black shale	Less Porous aquifer with minor fractures
---UNCONFIRMITY---				
Azoic	Archaean	--	Charnockites, Granites, Gneisses	Fractured Aquifer

Source: *cpheeo.nic.in*

4.2.4 Land Use

76. While there is no great increase in extent of lands zoned for urban activities, the intensity of development is likely to increase in sparsely developed and less developed areas to optimum levels thus increasing the efficiency of urban form. Restricting reclassification and open layout developments would prevent urban sprawl beyond the area zoned for urban development. In the North, large industrial units are located at Ennore, Thiruvottiyur and Manali; industrial estates are located at Madhavaram, Kodungaiyur and Gummipoondi. In the West important industrial locations include Ambattur, Padi and Sembiam. ICF Perambur and HVF Avadi are important industries under public sector. Many small and medium scale industries are located at Ambattur, Villivakkam, Thirumazhisai, Poonamallee and Noombal. Thermal power plant is located at Basin bridge. Hyundai car factory at Sriperumbudur, Hindustan Earth Movers at Tiruvallur and automobile industries at Irugattukottai are other important industries. In the south most of the industries are located along the G.S.T Road (NH45). Simpson, Addison and TVS

¹⁶ http://agritech.tnau.ac.in/agriculture/agri_soil_soilratingchart.html

industries are located in the heart of the City along Anna Salai. Madras Export Processing Zone (MEPZ) spread over an area of 105 hectares is located at Tambaram. Leather tanneries and leather-based industries are located near Tambaram.

77. Large-scale automobile engineering, glass and ceramic industries are located at Maraimalai Nagar. Mahindra Industrial Park developed over an area of 520 hectares is located near Chengalpattu along the GST Road. The highlights of land use in CMA are residential use and water bodies. Land use in year 2006 is depicted in Figure 4.4 and classified in Table 4.6. The predominant land use pattern along the corridor 4 is dominated by residential and commercial. The buildings along the alignment of Corridor 4 are majorly low rise varying from 4 to 6-storey.

Figure 4-4: Land Use in Chennai Metropolitan Area 2006

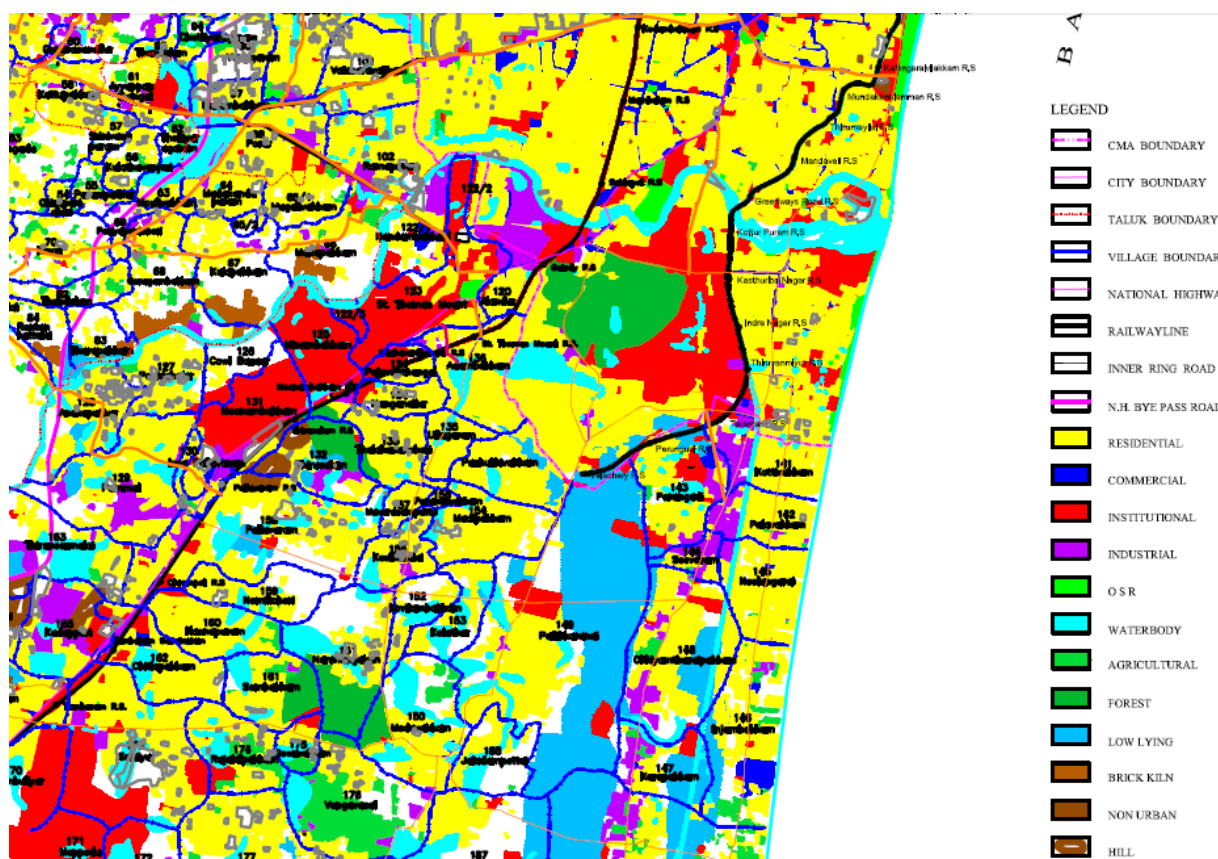

Source: Second Master Plan for Chennai Metropolitan Area, 2026

Table 4-6: Land Use in CMA

Land use	Land use 2006		Land use 2026	
	Area (ha)*			
	Chennai City	Rest of CMA	Chennai City	Rest of CMA
Residential	9,523	22,877	8,342	45,593
Commercial	1,245	390	714	880
Industrial	908	6,563	822	10,690
Institutional	3,243	3,144	2,868	3,888

	Land use 2006		Land use 2026	
Open Space and Recreational	366	200	1,000	392
Agricultural	99	12,470	Nil	7,295
Non-urban	82	2,433	113	2,333
Others	2,087	56,507	3,754	28,147
Urbanisable	Nil	Nil	Nil	2,075
Total	17,553	104,584	17,613	101,293

* Rounded off Source: Second Master Plan for Chennai Metropolitan Area, 2026

4.2.5 Seismicity

78. As per seismic zoning map of India shown at Figure 4.5, Tamil Nadu and Chennai are located in Moderate Seismic Zone (Zone III–BIS: 1893 (2001)). A study of seismic hazard for representative locations in Chennai (Seismic Hazard Assessment of the city of Chennai, India, Subhadeep Banerjee and A Boominathan, ASEM, Aug-Sept 2017) concluded that Santhome falls in class D; Vadapalani and Alwarpet fall in class C. Out of 5 classes (A, B, C, D and E) of soil that have been defined (NEHRP, USA) to rate building shaking due to seismic events, class A is the least vulnerable and class E is most vulnerable. Another micro zonation study (First level seismic micro zonation map of Chennai city - A GIS approach, Ganapathy, Natural hazards and earth system sciences 11(2) · February 2011) concluded that hazard for Santhome to Nandanam section except Alwarpet is low and Nandanam to Alwarthiru nagar section is moderate as depicted in Figure 4.6.

Figure 4-5: Seismic Zone Map of India

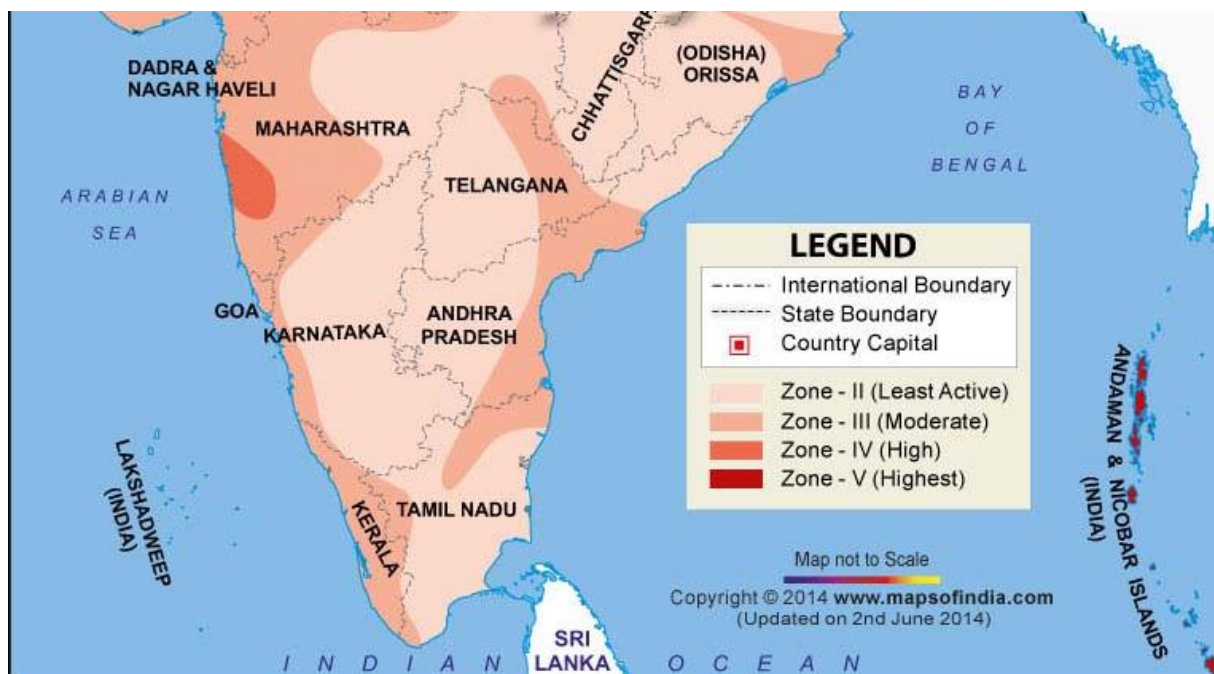

Figure 4-6: Seismic micro zonation of Chennai

558

G. P. Ganapathy: First level seismic microzonation map of Chennai city

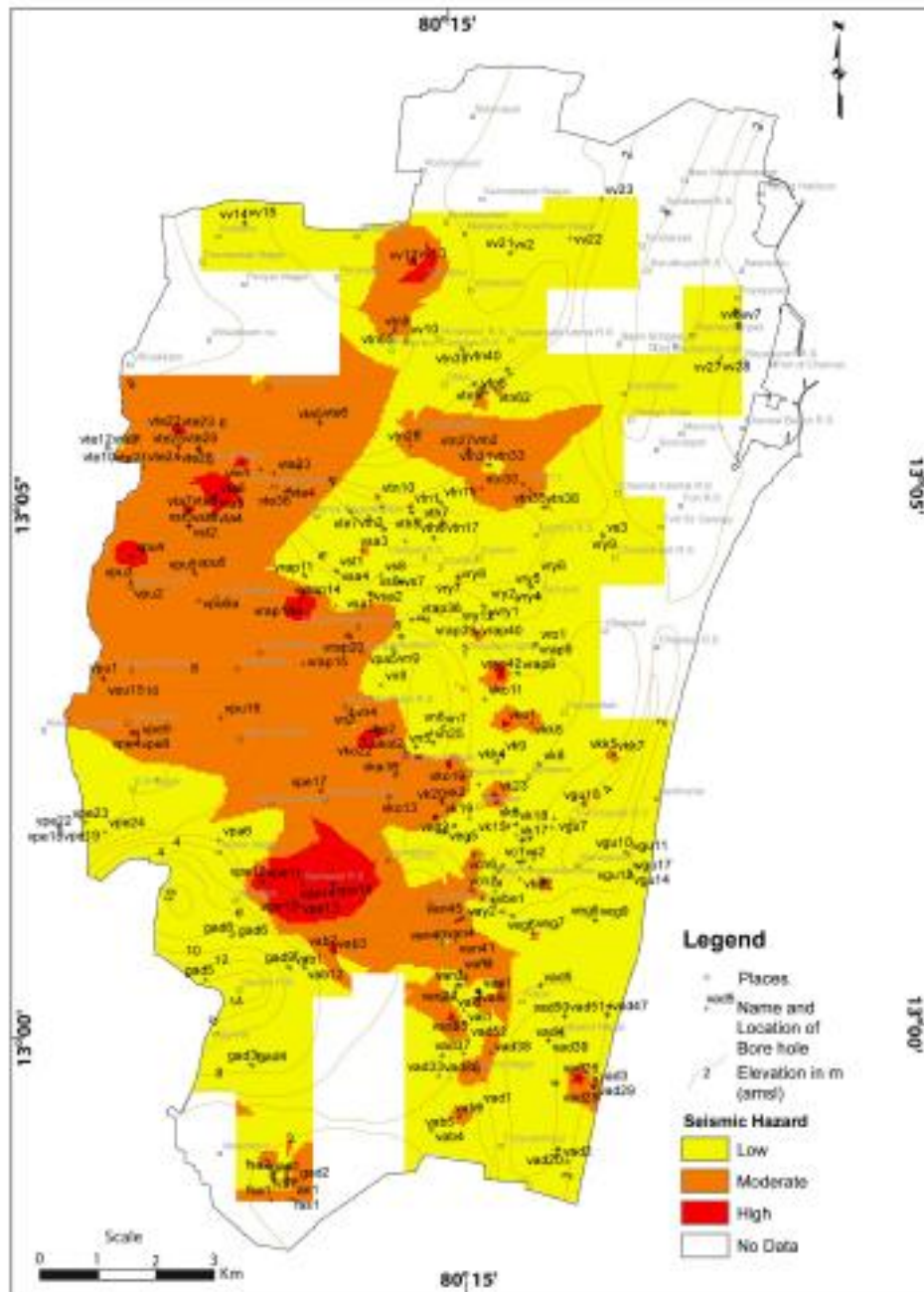

Fig. 8. First level seismic microzonation map of Chennai city.

Nat. Hazards Earth Syst. Sci., 11, 549–559, 2011

www.nat-hazards-earth-syst-sci.net/11/549/2011/

First level seismic micro zonation map of Chennai city - A GIS approach, Ganapathy, Natural hazards and earth system sciences 11(2) · February 2011

79. Last reported tremor in Chennai was on 12 February 2019 due to earthquake measuring 5.1 Richter (Source: IMD) with epicenter 10 km deep in Bay of Bengal.

80. The known faults and shear zones of the peninsular shield closely follow the pattern of major rivers. The fault details around Chennai city are listed in Table 4.7 which shows that none of them passes through the project site.

Table 4-7: Seismic FaultsTable 1. *The details of faults and seismicity in the vicinity of Chennai city.*

Sl. no.	Name of fault	Fault length <i>L</i> (km)	Distance (km)	Hypocentral distance, <i>R</i> (km)	Moment magnitude (<i>M_w</i>)	PGA (g)
1	Fault 15d	40	10	14	4.0	0.066
2	Fault 24	365	10	14	4.4	0.106
3	Fault 53	137	32	34	4.1	0.029
4	Kilcheri fault	26	33	34	4.0	0.025
5	Fault 15a	105	46	47	4.5	0.032
6	Neotectonic fault	105	48	49	3.8	0.013
7	Palar fault	85	59	60	4.0	0.013
8	Tambaram fault	10	59	60	4.4	0.021
9	Fault 15	96	61	62	3.7	0.009
10	Fault 52	115	67	68	3.6	0.007
11	Fault 15e	50	68	69	4.5	0.020
12	Fault 54	129	70	71	3.8	0.009
13	Mahapalipuram fault	5	75	76	4.0	0.010
14	Kalkulam fault	36	82	83	3.6	0.005
15	Muttukadu fault	11	95	96	3.5	0.004
16	Fault 26d	160	96	97	4.5	0.013
17	Fault 56e	75	97	98	4.5	0.013
18	Fault 26	1000	98	99	4.5	0.013

(Source: Seismic hazard assessment of Chennai city considering local site effects A Boominathan*, G R Dodagoudar, A Suganthi and R Uma Maheswari, *J. Earth Syst. Sci.* 117, S2, November 2008)

4.2.6 Meteorology

4.2.6.1 Temperature

81. Chennai has a tropical wet and dry climate. The city lies on the thermal equator and is also on the coast, which prevents extreme variation in seasonal temperature. Meteorological data like monthly total rainfall, maximum & minimum temperature, wind rose and relative humidity of the Chennai for a period of Jan 2011 to Dec 2017 collected from Indian Meteorological Department (IMD). Table 4.8 and Table 4.9 depicts that the hottest part of the year is in the month of May with maximum temperature varies 41.0°C to 43.0°C. The coolest part of the year is in the month of January, with minimum temperature varies 17.7°C to 20.3°C.

Table 4-8: Monthly Highest Maximum Temperature (Deg C)

YEAR	Jan	Feb	Mar	Apr	May	Jun	Jul	Aug	Sep	Oct	Nov	Dec
2011	31.1	32.6	37.7	35.7	41.7	38.6	38.0	36.9	36.4	35.4	32.6	31.6
2012	31.2	33.6	36.3	35.6	42.5	42.4	38.8	37.3	36.8	36.0	33.6	31.0
2013	30.9	32.5	35.1	37.4	42.7	39.7	38.3	36.9	35.7	35.6	33.6	32.1
2014	30.6	32.3	36.6	38.6	42.8	41.8	39.2	38.5	36.7	36.2	32.5	31.8
2015	31.3	33.1	35.1	36.8	42.2	39.6	41.0	37.6	36.9	35.7	32.6	32.4
2016	33.0	34.0	39.0	41.0	41.0	39.0	37.0	38.0	37.0	37.0	34.0	31.0
2017	31.0	36.0	36.0	41.0	43.0	41.0	39.0	37.0	36.0	36.0	34.0	33.0

Source: Regional Meteorological Centre, Chennai

Table 4-9: Monthly Lowest Minimum Temperature (Deg C)

YEAR	Jan	Feb	Mar	Apr	May	Jun	Jul	Aug	Sep	Oct	Nov	Dec
2011	18.7	17.7	20.1	23.5	23.1	22.7	23.1	20.5	21.6	22.6	18.7	19.0
2012	17.7	19.2	22.4	25.7	27.1	24.2	22.6	23.7	22.0	22.2	17.6	20.7
2013	19.0	19.5	20.4	25.3	24.8	24.7	23.2	23.6	23.0	23.8	22.0	19.1
2014	20.3	19.0	22.1	25.6	24.3	23.0	23.6	22.9	23.7	23.4	21.3	21.0
2015	19.0	20.8	23.2	23.5	25.6	24.6	23.9	23.1	23.5	24.3	22.4	21.5
2016	19.0	20.0	23.0	25.0	25.0	24.0	24.0	24.0	23.0	22.0	19.0	19.0
2017	19.0	19.0	22.0	26.0	27.0	25.0	24.0	24.0	24.0	23.0	23.0	21.0

Source: Regional Meteorological Centre, Chennai

4.2.6.2 Rainfall

82. Chennai gets most of its seasonal rainfall from the North–East monsoon, from October to December. South-West monsoon prevails from June to September. Cyclones in the Bay of Bengal sometimes hit the city. The highest annual rainfall recorded is 1,049.3mm in November 2015, the highest recorded since November 1918 when 1,088 mm of rainfall was recorded. The monthly rainfall is given in Table 4.10.

Table 4-10: Monthly Rainfall (mm)

YEAR	Jan	Feb	Mar	Apr	May	Jun	Jul	Aug	Sep	Oct	Nov	Dec
2011	10.8	88.9	0.0	18.5	12.6	130.2	67.4	368.9	286.2	260	457.2	134.8
2012	16.3	0.0	1.6	0.2	0.0	24.7	79.9	89.5	214.1	422.6	47.0	125.5
2013	Trace	14.3	11.9	3.6	3.6	34.0	146.6	195.1	240.1	157.2	193.7	85.9
2014	0.1	9.9	0.0	0.0	13.5	96.2	69.7	222.6	130.8	405.5	196.9	149.9
2015	2.8	0.0	0.0	12.3	7.9	20.3	205.9	106.5	75.0	159.9	1,049.3	454.7
2017*	0.0	5.0	2.5	0.0	0.5	60.0	55.0	90.0	65.0	160.0	155.0	9.0

Source: Regional Meteorological Centre, Chennai, *www.meteoblue.com

4.2.6.3 Humidity

83. Mean Relative Humidity is presented in Table 4.11 and Table 4.12. It varies 56% to 100% at 08:30 hrs and 57% to 87% at 17:30 hrs. 2016 and 2017 data were collected at different time slots.

Table 4-11: Monthly Mean Relative Humidity at 08:30 hrs (%)

YEAR	Jan	Feb	Mar	Apr	May	Jun	Jul	Aug	Sep	Oct	Nov	Dec
2011	82	81	77	75	64	60	70	79	80	84	85	88
2012	83	77	76	72	65	56	68	73	76	83	80	84
2013	88	84	80	77	73	61	80	83	82	86	86	80
2014	78	79	72	72	67	64	70	78	77	82	82	83
2015	83	81	74	72	69	66	70	77	77	83	91	86
2016*	94	100	94	94	100	100	100	100	100	94	100	100
2017*	100	94	94	94	89	100	100	100	100	100	100	100

Source: Regional Meteorological Centre, Chennai, * at 05.30 hrs (www.timeanddate.com)

Table 4-12: Monthly Mean Relative Humidity at 17:30 hrs (%)

YEAR	Jan	Feb	Mar	Apr	May	Jun	Jul	Aug	Sep	Oct	Nov	Dec
2011	60	61	59	67	65	58	57	69	74	80	76	67
2012	68	61	68	70	65	59	61	70	73	77	73	78
2013	75	72	69	77	74	60	76	76	78	81	81	73

YEAR	Jan	Feb	Mar	Apr	May	Jun	Jul	Aug	Sep	Oct	Nov	Dec
2014	69	67	64	68	68	66	65	74	75	80	77	76
2015	73	71	67	69	69	65	70	71	75	78	87	78
2016*	38	30	29	30	30	37	37	33	37	30	27	27
2017*	35	24	38	23	25	16	33	42	47	36	43	40

Source: Regional Meteorological Centre, Chennai, *at 14.30 hrs(www.timeanddate.com)

4.2.6.4 Wind

84. The wind rose diagram has been prepared based on the daily data for the period of 10/2009 to 08/2016. The prominent direction is NE, ESE and SE. Wind rose diagram for the Chennai is shown in Figure 4.7.

Figure 4-7: Wind Rose Diagram for Chennai

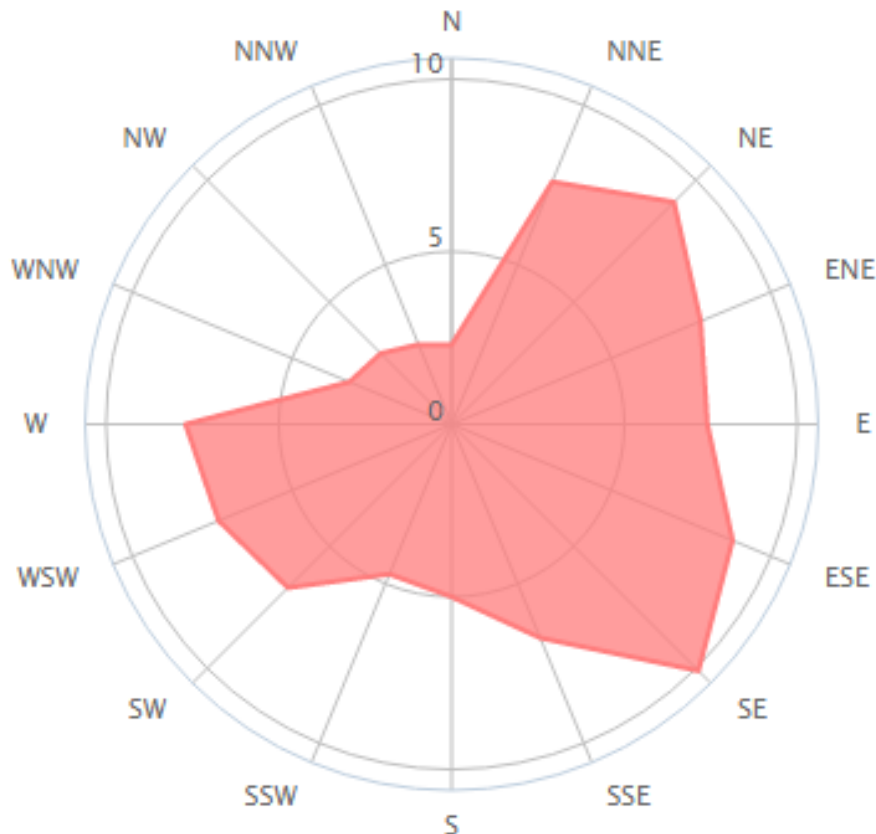

4.3 Ambient Environment

85. In order to assess the impact on existing ambient environment due to Corridor 4, it is necessary to have baseline status of ambient environmental parameters.

4.3.1 Water Resources

86. As the city lacks a perennial water source, catering the water requirements of the population has remained an arduous task. Groundwater levels from 2013 to 2016 were up to 10m below ground in pre-monsoon as well as post-monsoon seasons and rise in water level of up to 4m in 80% to 90% of observation wells in Chennai district between pre-monsoon and post-monsoon months. From May 2016 and January 2017, the groundwater levels were up to 4m in 46% of observation wells (*Groundwater Yearbook of Tamil Nadu and UT Puducherry, Central Groundwater Board*).

87. As per data provided by Chennai water authority, in 2017, the combined water level in the four reservoirs namely Red Hills, Cholavaram, Chembarambakkam and Poondi lakes was 4,365 mcft or 330 MLD. In May 2019 the combined storage level of these reservoirs was about 160 mcft or 8 MLD. On 19 June 2019, Chennai city officials declared that "Day Zero", or the day when almost no water is left, had been reached, as all the four main reservoirs supplying water to the city had run dry. Two years of deficient monsoon rainfall, particularly in late 2017 and throughout much of 2018 had led to this crisis (*India Today 20 June 2019*).

88. Chennai receives about 985 MLD from various sources against the required amount of 1,200 MLD. As of year 2018, 300 million litres of water was estimated to have been sourced from the four reservoirs in Chennai with their storage standing at 40% of their capacity; 180 MLD from the desalination plants in Minjur and Nemmeli and 70 MLD (against the usual 180 MLD) from Veeranam tank. Krishna water of about 400MLD supplements these sources; and other water sources, including abandoned stone quarries, agriculture wells and Neyveli Corporation mines. (*Down to Earth 22 May 2019*).

4.3.2 Drainage

89. Adyar River originates at the confluence (Thiruneermalai) of two streams that drains the upstream area of Chembarambakkam tank. It is a small river of 42 km length and a catchment of 800 Sq. km. The river carries flow all through 365 days of a year with an average discharge of 89.43 MCM/Year at Kathipara cause way. It drains the southern part of the district and remains flooded during monsoon. During the high tides, the backwater from the Bay of Bengal enters inland up to 3 – 4 km.

90. Cooum is the other main river flowing through the central part of the district and carries only drainage water, which is highly polluted. It originates from the surplus waters from the Cooum tank in Tiruvallur taluk and the tanks, which are in enroute, discharge their surplus water into the river during flood season. The flow of Cooum River at Korattur is 40.2 MCM/year for an average duration of 31 days in a year.

91. Otteri Nulla is another small stream flowing in the northern part of the city. Buckingham canal is the man made one for navigation purposes earlier, but now it act as sewerage carrier in the city.

4.3.3 Water Quality

92. The analysis of water samples is presented in Table 4.13. Laboratory analysis of water sample depicts that most of the parameters are well within the prescribed permissible limits as per the Bureau of Indian Standards except some parameters viz Turbidity at 4A, and 5C, Total Dissolved Solids, Calcium, Total Hardness, and Chloride at 4G, Lead at 4E exceed the permissible limit. Bacteriological contamination found at 4A, 4B, 4C, 4D and 4H. Total Dissolved Solids (TDS) and Total Hardness at Santhome Church sampling location are higher than limits, this could be due to higher mineral content in the groundwater especially Calcium and Magnesium. Laboratory analysis of water sample depicts at most locations that TDS, hardness and coliform are more than prescribed desirable limits for drinking water.

Table 4-13: Results of Laboratory Analysis of Water Sample

S. N	Parameter	Unit	Corridor 4									Acceptable/Permissible Limit for drinking water IS 10500
			4A	4B	4C	5C	4D	4E	4F	4G	4H	
1	pH at 25°C	-	6.87	6.77	6.62	7.13	7.21	7.49	6.56	7.31	7.45	6.5-8.5/no relaxation
2	Turbidity	NTU	59.2	<0.1	<0.1	67.3	<0.1	5.5	<1	<1	<1	1/5 max
3	Total Dissolved Solids	mg/L	1186	1104	675	1826	612	1412	56	4510	418	500/2000 max
4	Aluminium as Al	mg/L	BDL	BDL	BDL	BDL	BDL	0.05	BDL	BDL	BDL	0.03/0.2 max
5	Free Ammonia (as NH ₃)	mg/L	<0.1	>0.1	<0.1	<1	<0.1	<0.1	<0.1	<0.1	<0.1	-
6	Barium (as Ba)	mg/L	BDL	BDL	BDL	0.13	BDL	0.058	BDL	0.099	BDL	0.7 max/ no relaxation
7	Boran (as B)	mg/L	BDL	BDL	BDL	0.004	BDL	BDL	BDL	BDL	BDL	0.5/1
8	Calcium as Ca	mg/L	100.2	116.2	76.2	82.6	48.1	57.8	2.1	289	32.1	75/200
9	Chloride as Cl	mg/L	207	182.3	123.2	670.1	98.6	409	14.8	2118.8	113.3	250/1000
10	Copper as Cu	mg/L	0.0021	0.0023	BDL	BDL	0.0021	BDL	BDL	0.007	BDL	0.05/1.5
11	Fluoride as F	mg/L	>1	>1	>1	>1	>1	>1	<0.1	>1	<1	1.0/1.5
12	Iron as Fe	mg/L	BDL	BDL	BDL	0.15	BDL	BDL	BDL	BDL	BDL	0.3/ no relaxation
13	Magnesium (as Mg)	mg/L	58.4	31.7	19.5	52.7	17	42.6	1.3	95.3	14.6	30/100
14	Manganese as Mn	mg/L	1.16	0.003	BDL	0.54	0.002	0.35	BDL	0.137	0.003	0.1/0.3
15	Nitrate as NO ₃	mg/L	BDL	70.8	21.6	BDL	1.2	5	BDL	11.3	BDL	45/ no relaxation
16	Phenolic Compounds	mg/L	BDL	BDL	BDL	BDL	BDL	BDL	BDL	BDL	BDL	0.001/0.002
17	Seleniem (as Se)	mg/L	BDL	BDL	BDL	BDL	BDL	BDL	BDL	BDL	BDL	0.01/ no relaxation
18	Silver (as Ag)	mg/L	BDL	BDL	BDL	BDL	BDL	BDL	BDL	BDL	BDL	0.01/ no relaxation
19	Sulphate as SO ₄	mg/L	312.7	196	50.8	46.1	85	61.7	BDL	224.2	BDL	200/400
20	Sulphide (as S)	mg/L	BDL	BDL	BDL	BDL	BDL	BDL	BDL	BDL	27.4	0.05/ no relaxation
21	Total Alkalinity as CaCO ₃	mg/L	223.3	396	310	460.6	467	539	9.8	372.4	BDL	200/600
22	Total Hardness as CaCO ₃	mg/L	490	420	270	422.3	190	319.3	10.3	1112.4	152.3	200/600
23	Zinc as Zn	mg/L	BDL	BDL	BDL	BDL	BDL	0.027	0.14	0.034	140	5/15
24	Cadmium (as Cd)	mg/L	BDL	BDL	BDL	BDL	BDL	BDL	BDL	BDL	BDL	0.003/ no relaxation

S. N	Parameter	Unit	Corridor 4									Acceptable/Permissible Limit for drinking water IS 10500	
			4A	4B	4C	5C	4D	4E	4F	4G	4H		
25	Cyanide (as CN)	mg/L	BDL	BDL	BDL	BDL	BDL	BDL	BDL	BDL	BDL	BDL	0.05/ no relaxation
26	Lead as Pb	mg/L	BDL	BDL	BDL	BDL	BDL	BDL	0.045	BDL	BDL	BDL	0.01/ no relaxation
27	Mercury (as Hg)	mg/L	BDL	0.0008	0.00093	0.006	0.00025	BDL	BDL	0.00045	BDL	BDL	0.001/ no relaxation
28	Nickel	mg/L	BDL	BDL	BDL	BDL	BDL	0.0025	BDL	BDL	BDL	BDL	0.02/ no relaxation
29	Total Arsenic as As	mg/L	BDL	BDL	BDL	BDL	BDL	BDL	BDL	0.004	BDL	BDL	0.01/0.05
30	Total Chromium (as Cr)	mg/L	BDL	BDL	BDL	BDL	BDL	BDL	BDL	BDL	BDL	BDL	0.05 max/no relaxation
31	Total Suspended Solids	mg/L	29.0	9	7	21	7	9	3	8	8	-	-
32	Vanadium (as V)	mg/L	BDL	BDL	BDL	BDL	BDL	BDL	BDL	BDL	BDL	BDL	-
33	Amonical Nitrogen (as N)	mg/L	<0.1	>0.1	<0.1	<1	<0.1	<0.1	<0.1	<0.1	<0.1	<0.1	0.5/No relaxation
34	Total Kjeldahl Nitrogen (as N)	mg/L	BDL	89	27.8	0.2	1.5	11.6	0.1	14.2	1.12	-	-
35	Chromium (as Hexavalent Cromium)	mg/L	BDL	BDL	BDL	BDL	BDL	BDL	BDL	BDL	BDL	BDL	-
36	Oil and Grease	mg/L	<5	<5	<5	<1	<5	<1	<1	<1	<5	-	-
37	Dissolved Oxygen	mg/L	6	6.8	6.6	4.6	6.7	4.4	6.1	4.9	5.7	-	-
38	Chemical Oxygen Demand	mg/L	32	24	16	64	20	64	Nil	52	56	-	-
39	Biochemical Oxygen Demand (3 day 27°C)	mg/L	13	9	6	23	8	20	Nil	19	20	-	-
40	Total Phosphate as P	mg/L	0.1	3.3	1.3	0.9	2.4	1.2	BDL	1.4	0.18	-	-
41	Dissolved Phosphate (as P)	mg/L	0.1	3.3	1.3	0.9	2.4	1.2	BDL	1.4	0.18	-	-
42	Sodium as Na	mg/L	135	137.5	110	575	165	455	10.9	925	75	-	-
43	Potassium as K	mg/L	5.8	47	24.3	15	24.8	29	BDL	61	12	-	-
44	Nitrate Nitrogen	mg/L	BDL	16	4.9	BDL	0.27	1.13	BDL	2.6	BDL	-	-
45	Total Nitrogen	mg/L	BDL	89	27.8	0.2	1.5	11.6	0.1	14.2	1.12	-	-

S. N	Parameter	Unit	Corridor 4									Acceptable/Permissible Limit for drinking water IS 10500
			4A	4B	4C	5C	4D	4E	4F	4G	4H	
46	Organic Phosphorus	mg/L	BDL	BDL	BDL	BDL	BDL	BDL	BDL	BDL	BDL	0.002 max
47	Coliform Count	MPN/100 ml	160	20	40	<1	90	<1	<1	<1	90	Absent
48	Fecal Coliform	MPN/100 ml	50	10	10	<1	30	<1	<1	<1	20	Absent
49	Total Coliform Organism	MPN/100 ml	250	69	80	<1	230	<1	<1	<1	200	Absent

4.3.4 Air Quality

93. The air pollutants emitted by point and non-point sources are transported, dispersed or concentrated by meteorological and topographical conditions. The monitoring results for ambient air quality are presented in Table 4.14. 24-hour air quality monitoring results indicates that the air quality was moderate, while the parameters of Sulphur dioxide (SO₂) and Nitrogen dioxide (NO₂) were within the permissible level of National Ambient Air Quality Standards (NAAQS) and World Health Organization (WHO) guideline. Particulate Matter was within NAAQS but exceeded WHO guideline. Concentration of Carbon Monoxide (CO) exceeded the permissible level of NAAQS in all the monitoring locations but was generally within WHO guideline. CO exceeded prescribed limits on Corridor 4. The NAAQS laid down by CPCB and WHO guideline are given in Table 4.15.

Table 4-14: Ambient Air Quality

Sl No	Parameter	Unit	Pollution							
			Corridor-4							
			4A	4B	4C	5C	4D	4E	4F	4G
1	Sulphur Dioxide (SO ₂)	µg/m ₃	5.52	12.16	10.47	9.58	8.48	9.43	8.82	10.50
2	Nitrogen Dioxide (NO ₂)	µg/m ₃	11.52	18.03	17.53	13.60	23.64	17.53	12.17	17.71
3	Particulate matter (PM ₁₀)	µg/m ₃	68.90	82.87	62.68	84.12	58.85	74.14	56.61	47.62
4	Particulate Matter (PM _{2.5})	µg/m ₃	36.67	48.75	38.33	41.67	34.64	24.74	29.28	33.33
5	Carbon Monoxide (CO)	mg/m ₃	6.0	7.0	6.0	6.0	5.0	8.5	5.8	8.0

Table 4-15: National Ambient Air Quality Standards

Pollutant	Time weighted Average	Concentration in Ambient Air*		WHO Guideline
		Industrial, Residential, Rural & Other Area	Ecological Sensitive Area	
Sulphur Dioxide (SO ₂) µg/ m ³	Annual	50	20	-
	24 Hours	80	80	-
Oxides of Nitrogen (NO ₂) µg/ m ³	Annual	40	30	40
	24 Hours	80	80	-
Particulate Matter (size less than 10µm) or PM ₁₀ µg/ m ³	Annual	60	60	20
	24 Hours	100	100	50
Particulate Matter (size less than 2.5µm) or PM _{2.5} µg/m ³	Annual	40	40	10
	24 Hours	60	60	25
Carbon Monoxide (CO) mg/ m ³	24 Hours	-	-	7
	8 Hours	02	02	10
	1 Hour	04	04	30
Ozone (O ₃) µg/m ³	8 Hours	100	100	100
	1 Hour	180	180	-
Lead (Pb) µg/m ³	Annual	0.5	0.5	-
	24 Hours	1.0	1.0	-
Ammonia (NH ₃) µg/m ³	Annual	100	100	-
	24 Hours	400	400	-

*Source: CPCB guidelines for AAQM

4.3.5 Noise

94. The noise data was collected at 8 noise monitoring stations at hourly interval during morning, afternoon and evening such that peak and off-peak hours are covered. Most of the stretch is along the existing road. Later in 2019, monitoring of noise was conducted at 30 sample locations with sensitive receptors which are located within 200 m on either side of the alignment of Corridor 4, as listed in Table 4.19 and shown in Figure 4.8. The noise monitoring results are given in Table 4.16 and Table 4.17.

Figure 4-8: Locations of noise monitoring at sensitive receptors on Corridor 4



Field Survey: Nov/Dec 2019

Table 4-16: Ambient Noise Level Monitoring Results (by land use)

Location	Land Use	Leq	L10	L50	L90	Lmax	Lmin	Lday	Lnight	LDN
Corridor-4 Light House to Poonamallee Bypass										
4A	Commercial	72.45	74.90	72.03	69.88	75.98	68.23	72.92	70.85	71.89
4B	Residential	62.90	66.22	61.12	55.87	67.06	52.36	62.79	57.32	60.06
4C	Residential	72.07	76.63	66.81	58.87	77.20	57.66	70.80	59.90	65.35
5C	Residential	81.19	80.55	76.27	63.35	81.60	61.26	77.66	66.61	72.13
4D	Residential	78.44	78.82	75.13	64.72	78.94	63.03	76.11	68.14	72.12
4E	Commercial	75.07	75.21	74.99	73.08	75.35	72.62	75.02	74.00	74.51
4F	Silence Zone (educational)	73.19	76.01	72.73	70.76	76.27	69.84	73.65	71.37	72.51
4G	Silence Zone (religious)	84.34	81.45	78.97	63.49	82.54	58.91	79.42	66.57	73.00

4E to 4G in July 2016, 4A,4B,4C,4D in May 2017

Table 4-17: Ambient Noise Level Monitoring Results (at sensitive receptors)

No	Name of the Sensitive Receptor	Locations on Corridor 4	Type of Sensitive Receptor	Distance from the outer most proposed tracks (m)	Leq (Day) 50 dB(A)	Leq (Night) 40 dB(A)
1	Queens Mary College	Light House Station - Fore shore Estate Road	College	94.57	53.5	35.1
2	St. Thomas church	Light House Station - Fore shore Estate Road	Church	1.0	46.4	31.6
3	St. Bede's Anglo Indian Hr. Sec. School	Light House Station - Fore shore Estate Road	School	71.16	56.8	35.2
4	Santhome church	Foreshore Estate Road - Kutchery Road	Church	6.32	47.5	32.7

No	Name of the Sensitive Receptor	Locations on Corridor 4	Type of Sensitive Receptor	Distance from the outer most proposed tracks (m)	L _{eq} (Day) 50 dB(A)	L _{eq} (Night) 40 dB(A)
5	Rosary Church	Foreshore Estate Road - Kutchery Road	Church	1.0	44.3	30.4
6	St. Raphael's Girls Hr. Sec. School	Foreshore Estate Road - Kutchery Road	School	6.07	59.6	33.9
7	Majood Jamal	Kutchery Road - Thirumayilai Metro	Mosque	5.5	46.2	33.5
8	Jumma Mosque	Kutchery Road - Thirumayilai Metro	Mosque	11.87	43.7	34.6
9	Luz Church	Thirumayilai Metro - Alwarpet	Church	76.43	45.2	31.3
10	Anjaneyar Temple	Alwarpet - Bharathidasan Road	Temple	9.66	43.6	32.5
11	Trinity Hospital	Alwarpet - Bharathidasan Road	Hospital	7.58	52.8	38.2
12	AVT Hospital	Alwarpet - Bharathidasan Road	Hospital	28.9	55.1	36.8
13	SIET College	Adyar Gate Junction to Nandanam	College	31.17	57.3	35.3
14	Venkateshwara Hospital	Nandanam to Natesan Park	Hospital	38.23	51.6	37.9
15	Government Arts College	Adyar Gate Junction to Nandanam	College	18.48	56.9	33.4
16	Little Oxford Matriculation Higher Sec School	Nandanam to Natesan Park	School	73.81	50.4	34.7
17	Thyagarayar Higher Secondary School	Nandanam to Natesan Park	School	22.45	49.8	31.9
18	Thirumala Tirupathi Devasthanam	Nandanam to Natesan Park	Temple	25.6	54.6	49.6
19	Rose of Sharon Ac Church	Kodambakkam Metro to Meenakshi	Church	180.34	48.9	37.2
20	Meenakshi College for Women	Meenakshi College to Power House	College	120.9	52.9	35.7
21	Chennai Higher Secondary School	Power House to Vadapalani	School	19.00	56.2	34.3
22	Saraswathi Vidyalaya Sr. Sec. School	Power House to Vadapalani	School	12.79	54.7	33.3
23	Vijaya Hospital	Vadapalani to Saligramam	Hospital	15.70	51.1	39.1
24	Karthikeyan Matric School	Vadapalani to Saligramam	School	35.96	49.8	34.7
25	Narayanan E-Tecno School	Alwar thiru nagar to Valasarwakkam	School	14.17	47.3	36.5
26	The Holy Cross Matric Hr. Sec. School	Valasaravakkam to Karambakkam	School	87.30	52.6	38.1

No	Name of the Sensitive Receptor	Locations on Corridor 4	Type of Sensitive Receptor	Distance from the outer most proposed tracks (m)	L _{eq} (Day) 50 dB(A)	L _{eq} (Night) 40 dB(A)
27	Parvathy Hospital	Alapakkam Junction- Porur Junction	Hospital	57.56	48.3	36.7
28	Lakshmi Hospital	Ramchandra Hospital- Iyappanthangal Bus Depot	Hospital	38.38	52.7	37.6
29	Mangalam Hospital	Mullai Thottam to Poonamallee Bus Terminus	Hospital	23.85	54.1	35.3
30	Government Hospital	Mullai Thottam to Poonamallee Bus Terminus	Hospital	18.01	59.3	41.5

Field survey: Nov/Dec 2019

95. The Ambient Noise limits laid down by CPCB and WHO have been given in Table 4.18. The noise levels monitored at 8 locations along the alignment were above the national and international permissible limits. Noise levels was also monitored at 30 sensitive locations belonging to the silence zone, with 60% slightly exceeding the noise limits of 50dB the daytime limit (23.3% per WHO guideline of 55dB), and 1 out of 30 exceeding 40 dB the night-time limit. The predominant source of ambient noise at the monitored locations are from road traffic (urban arterials and regional highways).

Table 4-18: Ambient Noise Limits

Area Code	Category of Area	CPCB Limits in dB (A) Leq		WHO Guideline	
		Day time*	Night time	Day time	Night time
A	Industrial area	75	70	70	
B	Commercial area	65	55	70	
C	Residential area	55	45	55	45
D	Silence Zone**	50	40		

Source: CPCB guideline (as per The Noise Pollution (Regulation and Control) Rules, 2000)

* CPCB day time is from 6.00 AM to 9.00 PM, WHO defines day time as 7.00 AM to 10 PM.

****Silence Zone** is defined as an area up to 100m around premises of Hospitals, Educational Institutions, Courts of law and religious places or any others declared as such.

4.3.6 Vibration

96. Vibration consists of rapidly fluctuating motions of the particles without any net movement. Objects can vibrate differently in three mutually independent directions which are vertical, horizontal and lateral. It is common to describe vibration levels in terms of velocity, which represents the instantaneous speed at a point on the object that is displaced. Vibrations are transmitted from the source to the ground and propagate through the ground to the receiver.

97. The triaxial transducers are placed at proposed survey location. The signals obtained from all three axes are in horizontal, transverse and vertical directions viz. X- Easting, Y- Northing and Z-Vertical direction. The standard measurable units for velocity are in mm/s. Measuring the peak particle velocity (PPV) is mostly used for representation of vibrating

situation when the pressure wave passes through the particles. Soil conditions have a strong influence on the level of ground-borne vibration. The PPVs are usually expressed in terms of m/s or mm/s.

98. The dynamic analysis and seismic response have been studied for 13 identified sensitive receptors on Corridor 4 comprising educational institutions and hospitals which are located near by the project corridors as shown in Figure 4.9 & 4.10. Of these locations, 2 are heritage assets namely Rosary Church and Our Lady of Light Shrine; permission to conduct vibration study at the third heritage asset Santhome Church was not available.

Figure 4-9: Locations of vibration measurement at sensitive receptors Part 1

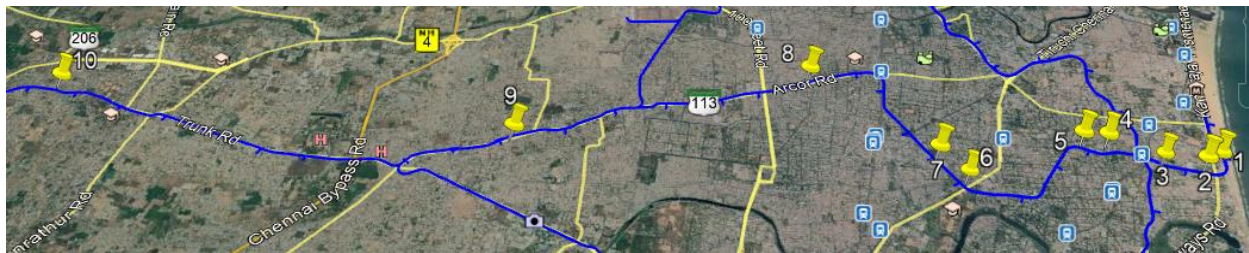

Field Survey: Nov 2019

Figure 4-10: Locations of vibration measurement at sensitive receptors Part 2

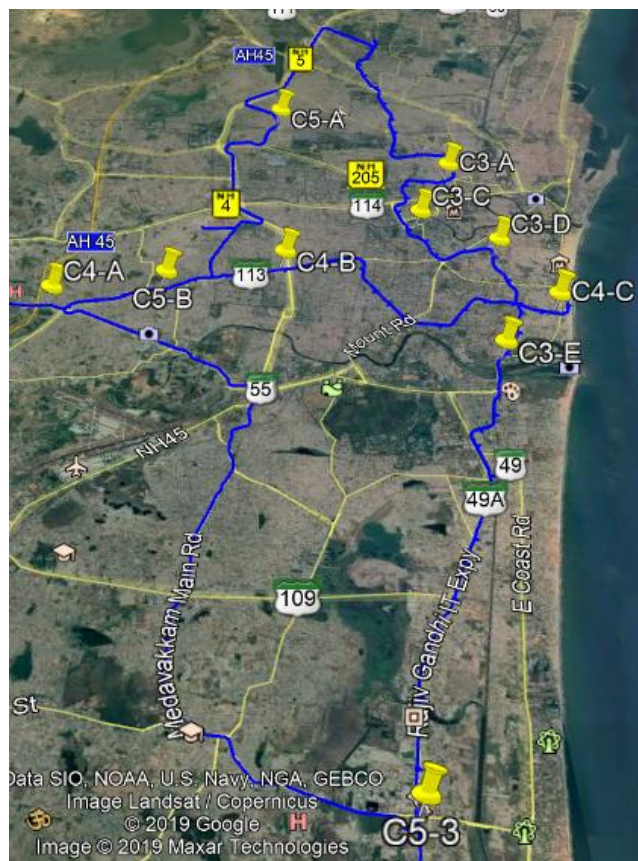

99. The induced ground vibration level is summarized in Table 4.21 and monitoring schedule is shown in Table 4.19.

100. All the measurements are characterized on ground level i.e., pickup point is on ground level. Peak VdB vibration level at 11 out of 13 monitored locations is found to exceed acceptable criteria for ground borne vibration prescribed by the Federal Transit Administration (FTA) USA

and Railway Design & Standards Organisation (RDSO) (**Annexure 3**). However the observed levels at all 13 locations are well below the construction vibration damage criteria for blasting as per Directorate General of Mines Safety (DGMS) and Central Institute of Mining and Fuel Research (CMFRI or CMRI) which are relevant only if blasting is undertaken during construction (Table 4.20).

Table 4-19: Monitoring Schedule

No	Location	Monitoring schedule	Duration (hrs)	Date of Commencement
Part 1				
1	C4-D-St.Bede's Anglo Indian School	10:35 AM – 6:52 PM	08	22/11/2019
2	C4-E-Aashraya Hospital	08:52 AM -5:00 PM	08	24/11/2019
3	C4-F- Jain Temple	11:47 AM - 7:59 PM	08	19/11/2019
4	C4-G- Luz Church	10:42 AM – 6:47 PM	08	17/11/2019
5	C4-H-Anjaneyar Temple	10:28 AM -6:37 PM	08	23/11/2019
6	C4-I – SIET College	11:16 AM - 7:24 PM	08	20/11/2019
7	C4-J-Thirupathi Thirumala Devasthanam Temple	8:43 AM – 5:01 PM	08	21/11/2019
8	C4-K-Koncept Hospital	10:34 AM - 6:38 PM	08	25/11/2019
9	C4-L-The Holy Cross Matric Hl. Sec School	10:19 AM - 6:28 PM	08	26/11/2019
10	C4-M- Government Hospital	09:46 AM – 5:47 PM	08	27/11/2019
Part 2				
C4-A	Near Porur Lake	7:45 PM -7:40 PM	24	20/07/2019 to 21/07/2019
C4-B	Vadapalani Junction	1:03 PM - 12:55 PM	24	19-07-2019 to 20-07-2019
C4-C	Santhome Church	9:57 AM - 10:03 AM	24	16-07-2019 to 17-07-2019

Table 4-20: Standards for Vibration

Type of structure	Vibration (mm/s) for dominant excitation frequency, Hz		
	< 8Hz	8-25Hz	>25Hz
DGMS			
(A) Buildings/structures not belonging to the owner			
Domestic houses/structures (kuccha, bricks & cement)	5	10	15
Industrial building	10	20	25
Objects of historical importance & sensitive Structures	2	5	10
(B) Buildings belonging to the owner with limited span of life			
Domestic houses/structures	10	15	20
Industrial buildings	15	25	50

After CMRI Standard (Dhar et al, 1993)

Type of structures	PPV (mm/s)	
	<24 Hz	>24 Hz
Domestic houses, dry well interior, construction Structures with Cemented, bridge	5.0	10.0
Industrial buildings, steel or reinforced concrete structures	12.5	25.5
Object of historical importance, very sensitive Structures, more than 50 years old construction and Structures in poor state condition	2.0	5.0
IS 14881:2001		
Soil, weathered or soft conditions: 70mm/s		
Hard rock conditions: 100mm/s		

Source: DGMS (Tech) (S&T) Circular No. 7 of 1997

Table 4-21: Baseline Vibration

S N	Name of location	Surface Type	PPV (Maximum) mm/sec			VdB (Maximum)			VdB (Average)			VdB RMS	
			East	North	Up	East	North	Up	East	North	Up	Max.	Time
Part 1													
1	C4-D-St. Bede's Anglo Indian School *	Marble	0.231	0.141	0.497	79.176	74.888	85.830	68.43	65.82	68.56	82.82 (Up)	02:26 PM
2	C4-E- Aashraya Hospital **	Cemented Floor	0.089	0.082	0.187	70.85	70.18	77.34	66.09	66.08	63.86	74.33 (Up)	3:19 PM
3	C4-F- Jain Temple ***	Marble	0.303	0.096	0.103	81.53	71.54	72.16	73.86	65.78	65.48	78.52 (East)	12:34 PM
4	C4-G- Luz Church	Cemented Floor	1.840	0.324	0.474	97.20	82.11	85.42	72.70	69.95	69.98	94.19 (East)	6:30 PM
5	C4-H- Anjaneyar Temple	Marble	1.110	0.504	0.833	92.81	85.95	90.32	75.64	68.62	75.55	89.80 (East)	02:25 PM
6	C4-I – SIET College	Marble	0.261	0.170	0.251	80.24	76.51	79.90	68.27	68.16	67.45	77.22 (East)	07:16 PM
7	C4-J- Thirupathi Thirumala Devasthanam Temple	Marble	1.420	0.499	0.792	94.95	85.87	89.88	79.25	69.78	75.51	91.94 (East)	11:54 AM
8	C4-K- Konzept Hospital ****	Marble	0.894	0.200	0.502	90.93	77.92	85.92	74.01	68.73	70.80	87.92 (East)	01:57 PM
9	C4-L-The Holy Cross Matric Hr. Sec School	Tiles	0.439	0.099	0.237	84.75	71.81	79.40	72.32	66.66	69.50	81.74 (East)	11:46 AM
10	C4-M- Government Hospital	Marble	0.311	0.250	0.266	81.76	79.86	80.40	69.31	66.37	69.08	78.75 (East)	10:23 AM
Part 2													
C4-A	Near Porur Lake	Soil	0.207	0.356	0.325	78.22	82.93	82.14	64.34	66.77	72.20	79.92 (North)	04:34 AM
C4-B	Vadapalani Junction	Soil	0.210	0.430	0.788	78.34	84.57	89.83	67.58	75.22	79.29	86.82 (Up)	06:36 AM
C4-C	Santhome Church	Soil	0.456	0.356	0.094	85.08	82.93	71.39	65.49	62.95	62.59	82.07 (East)	12:05 PM

Note: Representing locations of* C4-D- Queens Mary's College ** C4-E- Rosary Church *** C4-F- Jumma Mosque **** C4-K- Meenakshi College for Women

4.4 Ecological Environment

4.4.1 Ecologically Sensitive Areas in CMA

Figure 4-11: Ecologically Sensitive Areas in CMA

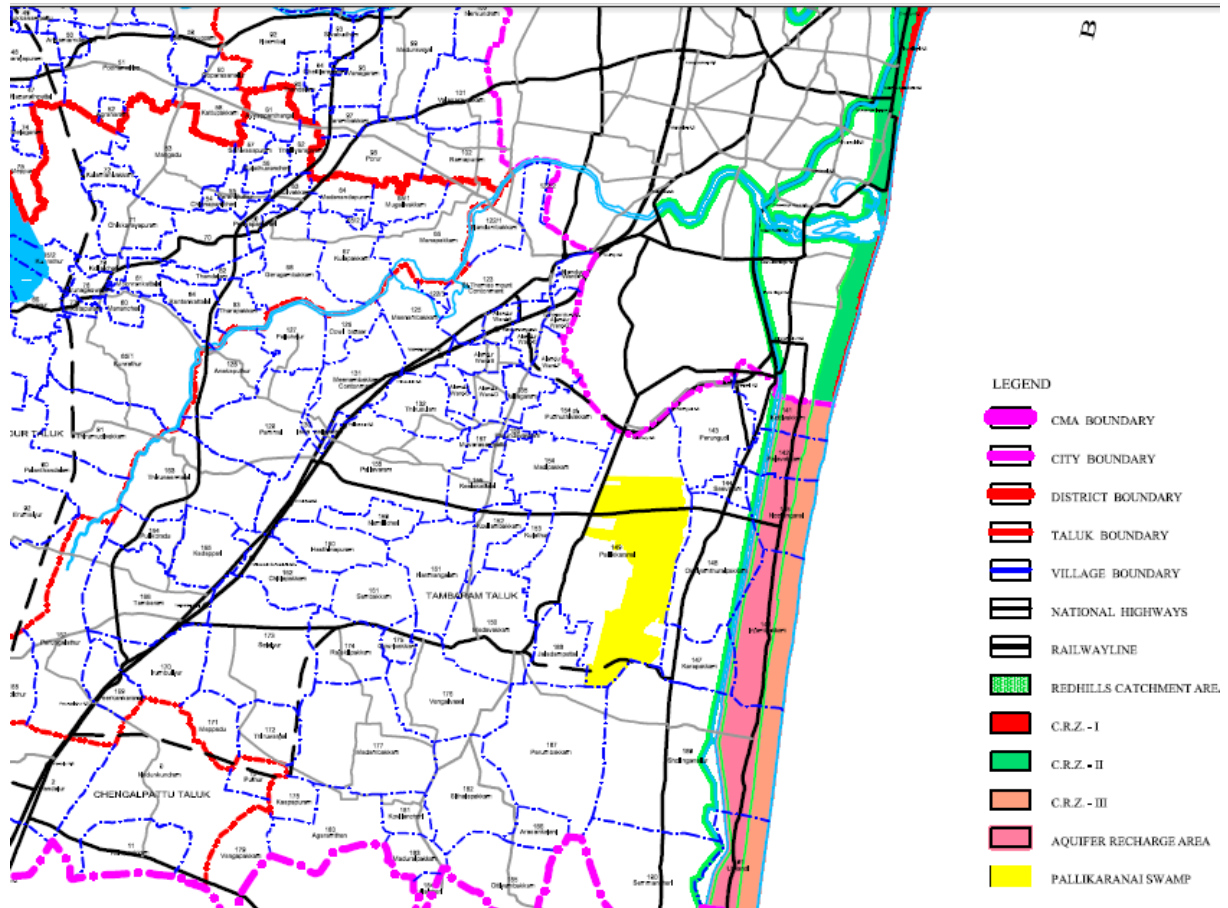

Source: Second Master Plan for Chennai Metropolitan Area, 2026

101. The ecologically sensitive areas in Chennai Metropolitan Area (CMA) are depicted in Figure 4.11.

102. The section of alignment from Lighthouse to Thirumayilai with a length of 2449 m along Corridor 4 falls in CRZ. The DPR alignment (shown in violet colour in Figure 4.11) from Lighthouse station to Kutchery Road is located in CRZ II category. And the other section between Kutchery Road and Thirumayilai Metro is identified as CRZ IV-B due to the alignment passes through the tidal influenced water bodies (shown in blue colour in Figure 4.12).

103. In the alignment (shown in brown in Figure 4.12) which is revised post-DPR, length of about 932m is located in CRZ II and a length of 50 m is located in CRZ IV-B.

104. However, the Foreshore Estate Road and Kutchery Road is a busy area. Figure 4.13 shows location of settlement constructed by Tamil Nadu Slum Clearance Board at location Nochikuppam. This development at Nochikuppam and Domminkuppam located west of Foreshore Road and South of Office of IG Police is executed under Emergency Tsunami Reconstruction Project funded by the World Bank. The sample photograph shows the Foreshore Estate Road and ETRP buildings where Foreshore Estate Road is congested with running traffic and fish market.

Figure 4-12: Alignment in Ecologically Sensitive Area

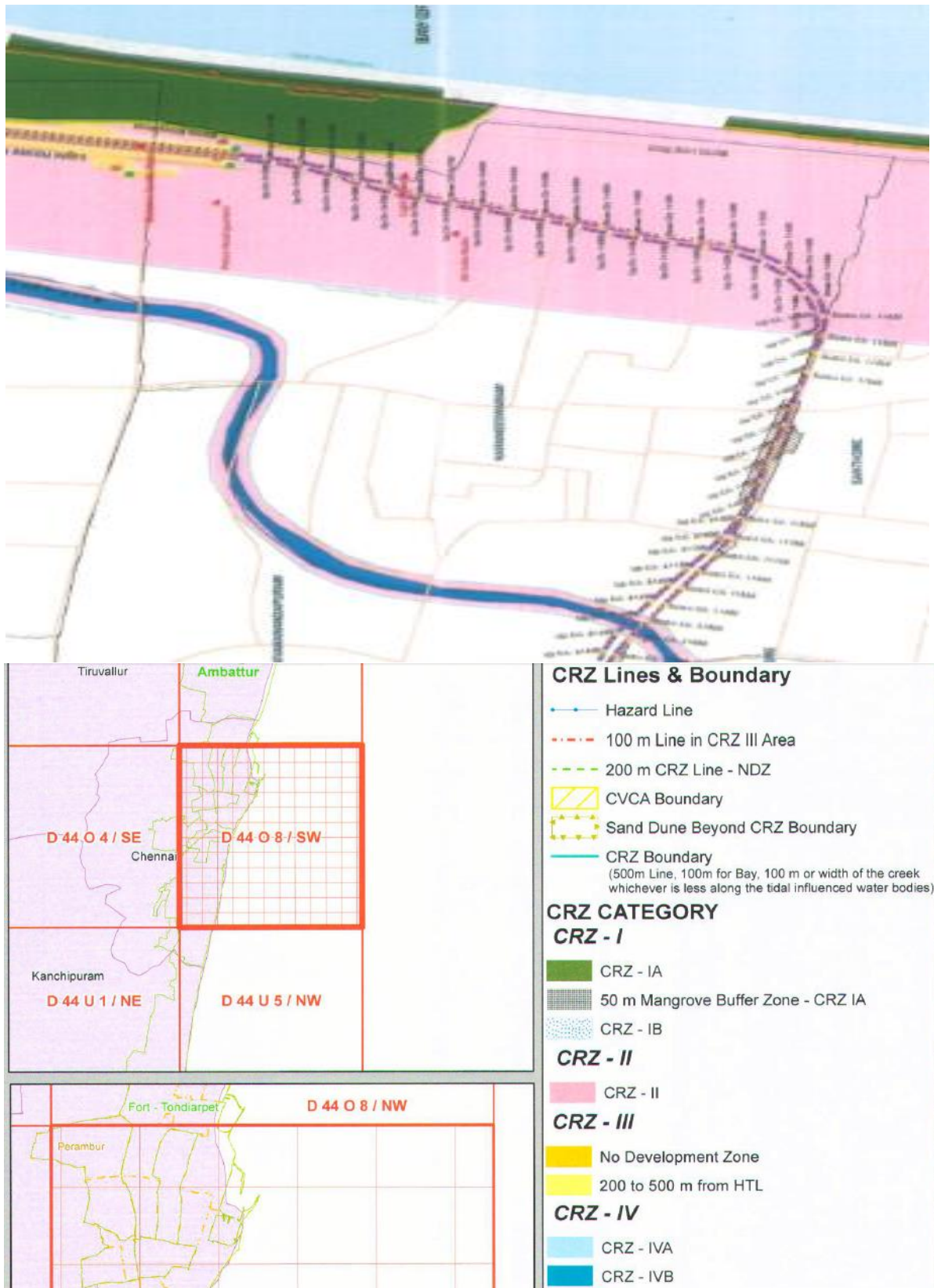

Source: Coastal Zone Management Plan Tamil Nadu Sheet No. D 44 O 8 /SW, NCSCM 2017-18

Figure 4-13: Emergency Tsunami Reconstruction Project on Foreshore Road

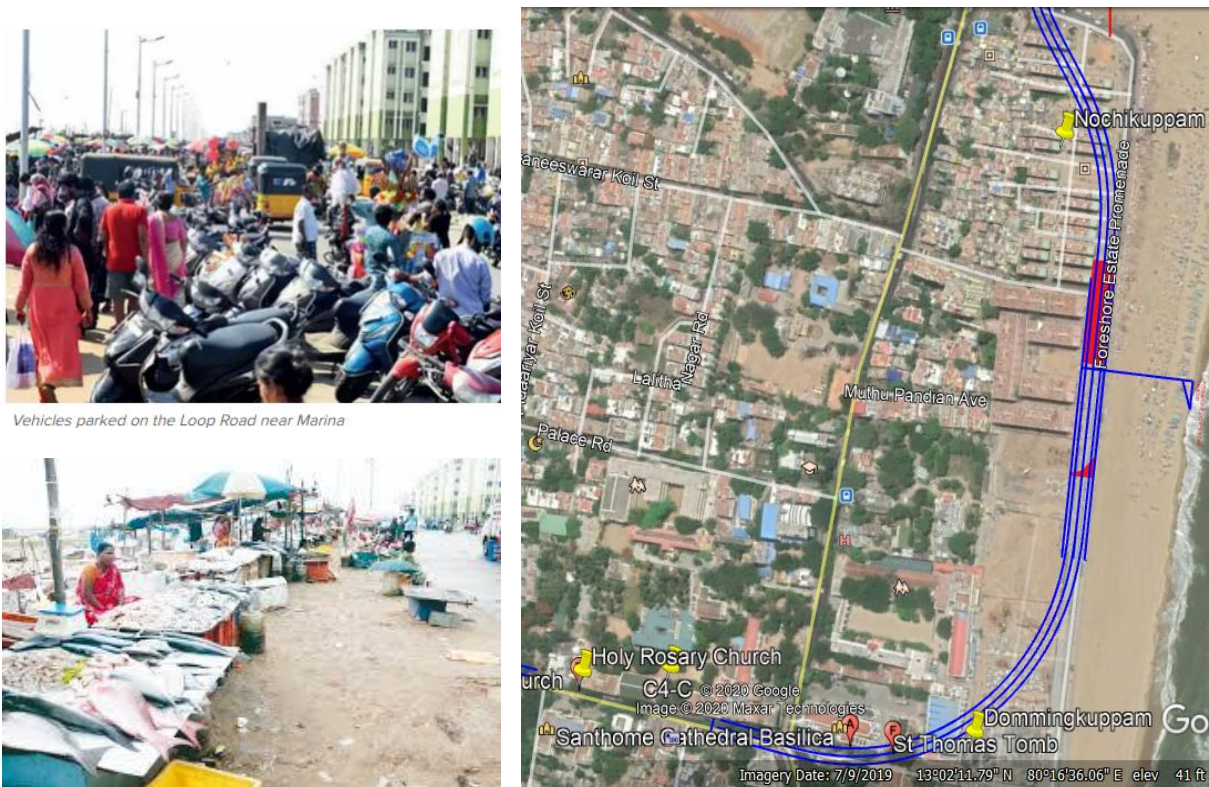

Source: Times of India, Feb 2, 2020

105. The elevated alignment of Corridor 4 is proposed to pass across Porur lake, which is located on the fringes of the suburb of Porur in south-west Chennai. Porur Lake functions as a source of water for the people residing in Chennai. It also acts as a drainage area that is connected with the Chembarambakkam Lake. As shown in Figure 4.13, Porur Lake is located at 13.034223 degrees north and 80.15065 degrees east. It occupies a water spread area of 250 acres with a capacity of 46 million cubic feet.

106. Since 1995, the government has prohibited activities like swimming, bathing and washing clothes in Porur Lake. In the year 2012, another initiative was taken by the Water Resources Department, not only to restore the lake, but also to meet the city's growing demands for drinking water. This project was aimed at increasing the capacity of the tank to 70 mcf. Many uncontrolled and illegal activities also termed as encroachment are responsible for disturbing the ecology of any setting or area. Porur Lake also acquired the ill fate of many other lakes in India in terms of degradation of water quality. This is evident from the observations of the residents of Porur. According to these residents, Porur Lake has turned into a dumping ground for garbage and the release of sewage. They have even emphasized on the fact that when this lake's bund would be breached, flooding of several localities around the lake would be its consequence. This troublesome event would take place every year during the monsoon season.

Figure 4-14: Porur Lake

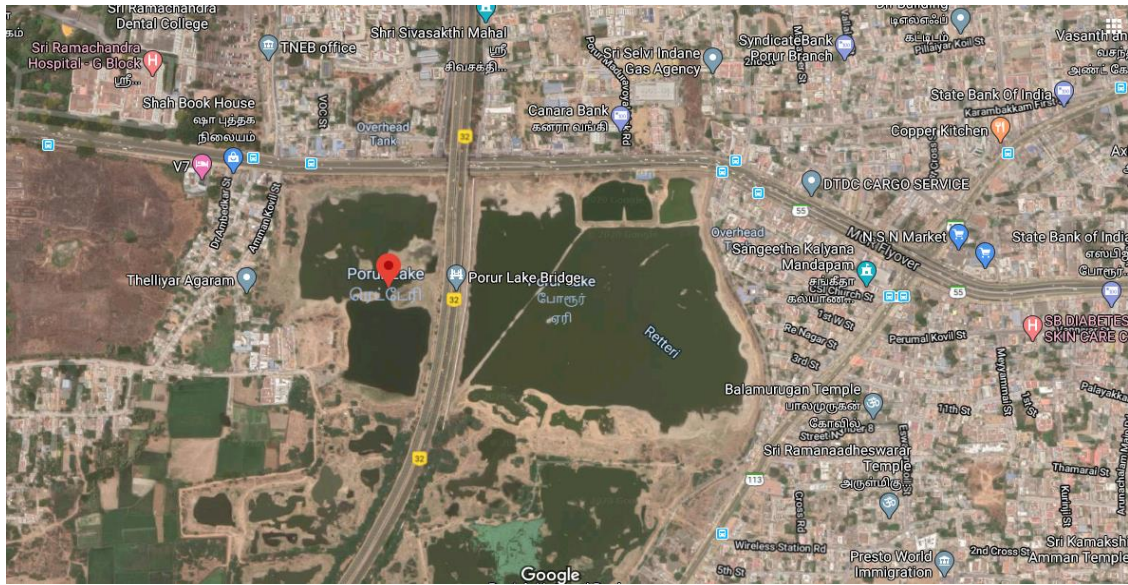

107. No mangroves are located near the project alignment. The nearest mangroves are those planted after flood of 2015 in Adyar river islands 2.2 km away and natural mangrove forest at Pichavaram 185 km away from Chennai. No forest area falls along Corridor 4. Forest cover map of Chennai district is shown in Figure 4.15.

Figure 4-15: Forest Cover Map of Chennai District



108. The following Table 4.22 lists the bird-watching areas in Chennai. (Source: Madras Naturalists' Society)

Table 4-22: Bird Watching Areas in Chennai

S.no	Location
1	Indian Institute of Technology, Adyar – tropical dry evergreen forest with exotic plantation
2	Pallikaranai Marsh – Open water interspersed with reeds and bulrushes
3	Adyar Estuary/creek/Adyar Poonga – Estuary with Mudflats
4	Nanmangalam Forest Reserve – Scrub covered slopes and water covered pools
5	Guindy National Park – Tropical Dry Evergreen Forest
6	Vandalur Hills and Zoo – Undulating terrain with original scrub and planted trees
7	Crocodile Bank – Coastal setting with artificial ponds and tall planted trees being used as a heronry
8	Pallavaram Hills – Original scrub and some trees
9	Manali and Madhavaram Jheel – Lakes
10	Edayanchatram – Open scrub
11	Thiruneermalai, Pammal – Hillock with some scrub
12	Red Hills and Cholavaram – Lakes
13	Ennore Creek – Coastal vegetation
14	Chemmencheri tank – Waterbody
15	Chembarampakkam lake

109. Guindy National Park with an area of 2.70 sq. km, which is under Reserve Forest category is classified as a Protected Area (ENVIS Centre of Wildlife and Protected Areas) and is located at distance of 2.6 km from the project alignment. In terms of density of vegetation cover, the area falls under sparse category.

110. The Guindy National Park is classified under tropical dry evergreen forests of the Coromandal coast and is being used for recreational purposes. The vegetation is mainly of the tropical dry evergreen type, and over 350 species of plants have been found including trees, shrubs, climbers, herbs and grasses. Chital and Blackbuck graze are found in the open grassland on the northern end of the park. Nocturnal animals include the toddy cat, civets, jungle cat, pangolin, and hedgehog. The dense forest, grasslands and water-bodies provide an ideal habitat for a large species of birds. Apart from snakes, certain species of tortoise and turtles, lizards, geckos, chameleons and the common Indian monitor lizard are also found here.

111. Vide letter dated 31 July 2013, MoEF&CC informed States that a default area of 10 km from the boundary will be the Eco-Sensitive Zone (ESZ) of such protected areas for which proposals identifying ESZs were not forwarded by the States to MoEF&CC. Corridor 4 falls in default ESZ of Guindy National Park. Vide MoEF&CC clarification dated 2 July 2012, projects falling in ESZs which are not covered under Notification 2006 and which do not require Environmental Clearance (EC) do not require prior approval of National Board of Wildlife (NBWL). As commercial development equal to or above threshold of 20,000 sqm is not proposed, prior EC need not be sought and hence prior approval of NBWL need not be sought. In accordance with 2011 Guidelines for declaration of ESZ around national parks and wildlife sanctuaries, activities relevant to the project are categorised in Table 4.23.

Table 4-23: Guidelines for ESZ Activities

Activity	Prohibited	Regulated	To be promoted
Discharge of effluents and solid waste in natural water bodies or terrestrial area	Yes	--	--
Felling of trees	---	Yes	---
Commercial use of natural water resources including ground water harvesting	---	Yes	---
Erection of electrical cables	---	Yes	---
Widening of roads	---	Yes	---
Movement of vehicular traffic at night	---	Yes	---
Air and vehicular pollution	---	Yes	---
Sign boards and hoardings	---	Yes	---
Underground cabling	---	---	Yes
Rain water harvesting	---	---	Yes
Renewable energy	---	---	Yes
Green technology for all activities	---	---	Yes

112. Some of the ecologically sensitive areas of Chennai district are shown in Figure 4.16.

Figure 4-16: Ecologically Sensitive Areas of Chennai District

113. The Nanmangalam Reserve Forest is home to 100-125 species of birds in addition to 40 different species of butterflies and close to 20 species of damselflies and dragonflies. 442

different species of flowering plants are found inside the forest alone. The Reserve Forest's most famous inhabitant and star attraction is the great horned owl.

114. Pallikaranai Marsh is a freshwater swamp. It is one of the three wetlands in the state of Tamil Nadu which are included in wetlands identified under National Wetland Conservation and Management Programme. (MoEF&CC Annual report 2006-2007). Biodiversity of Pallikarnai is seen in (*Source: nammapallikarnai.org*) 125 species of birds, 10 mammals, 21 reptiles, 9 amphibians, 49 fishes, 9 molluscans and 7 butterflies and 120 plant species. It is home to some of the most endangered birds such as the Black bellied tern, Great-knot and black -tailed godwit. Pallikarnai known for diverse variety of visitors and resident bird species. It is also home to some of the mostly rare reptiles such as the fan throated lizard, Russel viper and cobra. Other estuarine fauna present at the marsh includes the windowpane oyster, mud crab, mullet, halfbeak and green chromide. Plankton study shows that the water body is Eutrophic in nature.

4.4.2 Flora and Fauna

115. Corridor 4 passes through Panagal Park which is a recreation park; the metro station will be located underground. Tree count was carried out along the proposed alignment and in depot sites in 2018. Most of the trees exist along the sides of road and on median. The predominant tree species along the project corridors are listed below in Table 4.24.

Table 4-24: Predominant Tree Species along the Corridor (Local name- Botanical name)

Species	IUCN status
1. Vembu- <i>Azadirachta indica</i>	LC
2. Vadam- <i>Terminalia catapa</i>	LC
3. Nirkadambai - <i>Neonauclea purpurea</i>	NE
4. Thoongumoonji - <i>Albizia saman</i>	-
5. Panei - <i>Borassus flabellifer</i>	NE
6. Pungam - <i>Pongamia pinnata</i>	LC
7. MayirKonnai - <i>Delonix regia</i>	LC
8. Nettiingam- <i>Polyalthia longifolia</i>	NE
9. Vagai - <i>Albizia lebbbeck</i>	NE
10. Thennai - <i>Cocos nucifera</i>	NE
11. Shevaga - <i>Morinda tinctoria</i>	-
12. Nuna - <i>Bombax malabarica</i>	NE
13. Arasu - <i>Ficus religiosa</i>	NE
14. Al - <i>Ficus benghalensis</i>	NE
15. Ma - <i>Mangifera indica</i>	DD

Note: LC Least Concern; NE Not evaluated; DD Data Deficient; - Not known

116. The number of trees likely to be cut is presented in Table 4.25. No rare or endangered species of trees were noticed during field studies. To minimize tree cutting it is proposed to transplant young trees to the extent possible. Local forestry officials will be consulted to transplant the trees at suitable locations.

117. Common birds observed in the project area are pigeons, parrot, crows, and doves. The predominant mammals observed in the project area are mongoose, bat, Squirrel, monkey and mice etc. No rare or endangered species were noticed.

Table 4-25: Tree Cutting

S. No	Description	Number of Trees*
Corridor-4 (Light House to Poonamallee Bypass)		
1	Alignment	140
2	Poonamallee Bypass Depot	396
Sub-Total		536

**This figure will be confirmed upon completion of socio-economic survey, preparation of land plan and impact micro plan*

4.5 Socioeconomic Environment

4.5.1 Utilities

118. Corridor 4 is planned to run through the urban area above the ground i.e. elevated in less densely populated and underground in populated and sensitive areas. The alignment will cross drains, large number of sub-surface, surface and utility services, viz. sewer, water mains, storm water drains, telephone cables, overhead electrical transmission lines, electric pipes, traffic signals, roadside lights etc.

119. These utility services are essential and have to be maintained in working order during different stages of construction, by temporary/permanent diversions and relocation or by supporting in position. Any interruption to these will have serious repercussions on the most sensitive suburban services and direct impact on the public besides set back in construction and project implementation schedule & costs. Therefore, meticulous detailed survey and planning will be required to protect/divert the utility services. The utility maps and network information are attached in **Annexure 4**.

4.5.2 Physical Cultural Resources

120. No archaeological monuments/sites are located on or along the proposed corridors. Three draft lists of heritage assets in CMA are available (CMDA website). Phase I list which was sent in year 2013 comprised 20 assets in Grade I, 43 in Grade II and 3 in Grade III; Phase II list which was sent in year 2014 comprised 38 assets in Grade I, 3 in Grade II and none in Grade III; Phase III list which was sent in year 2016 comprised 29 assets in Grade I, 28 in Grade II and none in Grade III. In Grade I assets no interventions are permitted except to strengthen their life. In Grade II assets, internal changes and adaptive reuse will be generally allowed, but external changes will be subject to scrutiny; ensure the conservation of all special aspects. In Grade III assets, external and internal changes, and adaptive reuse would generally be allowed. Of these the following three are located close to the proposed alignment. These 3 heritage assets in Table 4.26 are as shown in photographs placed below.



Santhome Church



Rosary Church



Our Lady of Light Shrine

Table 4-26: Heritage Assets near the Alignment

S.no	Name of Heritage asset	Approx. distance from road Centre line followed by the C4 alignment (m)	Grade
1	National Shrine of Santhome Church, Santhome High Road, Santhome	1	I
2	Rosary Church, Rosary Church Road	1*	I
3	Our Lady of Light Shrine, Luz Church Road	73	I

Note: * Distance up to boundary is 1m, distance up to building is 17m.

4.5.3 Demographic Features

121. The Project will improve passenger transportation in Chennai Metropolitan Area which is projected to support resident population of 125.82 lakh in year 2026. As in year 2014, almost all households in the urban parts of the 3 districts contributing to CMA are supported by at least one employed person. In the project affected households, about 50% of are working on salary or daily wages or contract or job works, 40% are business owners; 17% of households are in vulnerable category comprising those below income poverty line (about 4%), socially weak communities and women headed households. The other socioeconomic baseline is described in the standalone Social Impact Assessment.

5. ANTICIPATED IMPACTS AND MITIGATION MEASURES

122. The potential impacts and risks were analyzed in the confines of Corridor 4 alignment's direct impact area, which is defined in this study as a strip of 15m, however, sensitive receptors located within 200m on either side of the alignment were identified. Influence area where most of the socio-economic and cumulative impacts will occur is defined as the entire confine of the area in Chennai city.

123. There are no environmentally sensitive areas along the alignment of the corridor 4 except about 932m length passing through CRZ II and length of 50 m passing through IV-B between Lighthouse station and Thirumayilai. The CRZ II stretch is defined as areas that have already been developed up to or close to the shore-line, and shows no record of sensitive aqua fauna. The negative environmental impacts will mainly occur during construction work and noise impacts during operation phase. The significant impacts screened are:

- Loss of about 536 trees for construction of metro rail alignment as well as depot area.
- Subsidence, noise and vibration due to tunnelling boring machine (TBM), excavation machines, and materials hauling.
- Safety risks, inconvenience of traffic nuisance and poor accessibility due to road closures and diversions, noisy conditions etc. will also be created due to plying of large number of heavy trucks transporting construction material, equipment and machinery in and around the project area.
- Increased noise and air pollution resulting from traffic volume during construction.
- Increased local air pollution due to rock crushing, cutting and filling works, and chemicals from asphalt processing.
- Risks for damage to structures from vibration during construction and operation stages.
- Risks and vulnerabilities related to occupational health and safety due to physical, chemical, biological, and radiological hazards during project construction and operation.
- Dislocation or involuntary resettlement of people as there will be a need for land acquisition for elevated as well as underground sections and also for depot.

5.1 Impacts Screening

124. Adverse impacts that are likely to result from Corridor 4 development have been listed in Table 5.1 under the following headings:

- Impacts and Mitigation Measures during Project Location and Design;
- Impacts and Mitigation Measures during Construction;
- Impacts and Mitigation Measures during Project Operation; and
- Impact and Mitigation Measures due to Depot.

Table 5-1: Impacts Screening

S.No	Parameter	Adverse Impacts											
		Duration			Extent			Intensity / Risk			Likelihood		
		Temporary	Permanent	Onsite	Local	CMA	Negligible	Low	Medium	High	Unlikely	Likely	Definite
A.	Impacts due to Location and Design (Pre-Construction)												
1	Social Impact		*		*					*			*
2	Loss of trees and Impact on ecosystems		*		*				*				*
3	Impact on utilities		*		*				*				*
4	Impact on Heritage assets	*		*				*					*
5	Flooding of project due to sea level rise resulting from climate change		*	*						*		*	
6	Flooding of project due to anomalous heavy rainfall	*			*					*	*		
7	Earthquake Risk		*	*					*			*	
8	Right of way		*	*					*				*
9	Alignment, Architecture and Station Planning		*	*						*			*
10	Use of Energy, Water and materials		*	*					*				*
11	Impacts due to Associated Facilities		*	*					*				*

S.No	Parameter	Adverse Impacts											
		Duration			Extent			Intensity / Risk			Likelihood		
		Temporary	Permanent	Onsite	Local	CMA	Negligible	Low	Medium	High	Unlikely	Likely	Definite
12	Location of construction yards	*		*					*				*
13	Location of muck disposal sites		*		*			*					*
B.	Impacts due to Project Construction												
1	Ambient Air Pollution	*			*				*				*
2	Noise and Vibration	*			*				*				*
3	Muck disposal		*			*			*				*
4	Waste disposal		*			*			*				*
5	Impacts due to labour camp	*			*			*				*	
6	Labour Safety	*		*					*			*	
7	Increased energy demand	*			*			*					*
8	Increased water demand	*			*				*				*
9	Impact on water Quality and soil quality	*			*			*				*	
10	Ground subsidence		*		*					*		*	
11	Dewatering	*		*				*					*
12	Storm water drainage and Soil Erosion	*		*				*				*	
13	Supply of Construction Material		*			*				*			*
14	Traffic and utility diversion	*			*					*			*

S.No	Parameter	Adverse Impacts											
		Duration			Extent			Intensity / Risk			Likelihood		
		Temporary	Permanent	Onsite	Local	CMA	Negligible	Low	Medium	High	Unlikely	Likely	Definite
C.	Impact due to Project Operation												
1	Noise		*		*				*				*
2	Vibration		*		*				*				*
3	Energy Consumption at stations		*		*				*				*
4	Water supply and Sanitation at Stations		*		*			*					*
5	Ground subsidence		*		*					*		*	
6	Electromagnetic interference		*	*				*					*
7	Depot • Water supply • Sewage and Effluent • Oil Pollution • Noise • Surface Drainage • Solid waste • Loss of trees		*	*				*					*
POSITIVE IMPACTS													
8	Employment Opportunities		*			*				*			*
9	Benefits to Economy		*			*				*			*
10	Direct benefits to passengers		*			*				*			*
11	Reduced fuel consumption		*			*				*			*

S.No	Parameter	Adverse Impacts											
		Duration			Extent			Intensity / Risk			Likelihood		
		Temporary	Permanent	Onsite	Local	CMA	Negligible	Low	Medium	High	Unlikely	Likely	Definite
12	Reduced air pollution		*			*				*			*

125. For each of these headings, potential impacts are evaluated and mitigating measures have been proposed.

5.2 Impacts and Mitigation Measures during Project Location and Design Phase

126. During this phase, those impacts, which are likely to take place due to the layout of the project, have been assessed. These impacts are:

- Change of Land use and Socio-economic impacts
- Loss of trees
- Loss of biodiversity
- Impacts on Utilities
- Impact on Physical Cultural Resources (PCRs)
- Climate Vulnerability
- Operational Noise and Vibration

5.2.1 Land Use and Socio-economic Impacts

127. The proposed project will require transfer of 34.23ha government land out of which 31.34ha is for Poonamallee depot and acquisition of 15.09ha private land out of which 7.64ha is for depot. 1,072 families comprising title holders, tenants and non-title holders who are residents physically displaced and business owners economically displaced due to acquisition of land and buildings will be affected by the project. These families comprise 1,565 persons. These figures will be revised upon completion of field socio-economic survey of affected families, revision of detailed drawings, preparation of land plan and micro plan of impacts.

128. The land acquisition, resettlement and socio-economic impacts are assessed in the SIA report.

5.2.2 Tree cutting

129. The construction of Corridor 4 will require cutting of about 536 public trees in total. None of trees to be cut are rare or endangered species. With removal of these trees, the process for CO₂ conversion will get affected and the losses are reported below:

- | | | | |
|------|--|---|---------------|
| i. | Total number of Trees | : | 536 |
| ii. | Decrease in CO ₂ absorption due to loss of trees: | | 1,608 kg/year |
| iii. | Decrease in Oxygen production due to tree loss: | | 5,896 kg/year |

130. Amount of oxygen produced per tree per year for urban forests was adopted as 11 kg (Oxygen Production by Urban Trees in the United States, David J. Nowak, Robert Hoehn, and Daniel E. Crane, Arboriculture & Urban Forestry 2007). Based on model for tropical trees (Tree allometry and improved estimation of carbon stocks and balance in tropical forests, J.Chave et al, Oecologia 2005) and wood density for Asian species as per Food Agriculture Organization (FAO), CO₂ sequestered per year per tree has been estimated for this report as 3 kg for typical tree of 30 cm girth.

131. Location for compensatory plantation will be decided by CMRL in consultation with owner of the land as well Forest Department such that displacement does not become necessary. Tamil Nadu Forest Department, Government of Tamil Nadu is responsible for the conservation and management of the trees. It is found that about 536 trees are likely to be lost in the project under line, stations and maintenance/stabling depot. It is proposed to plant twelve saplings for each tree to be cut. Hence 6,432 trees shall be planted. The native plant species and miscellaneous indigenous tree species are recommended for plantation.

132. At Panagal Park, an ecological restoration plan is required with a process of assisting the recovery of the ecosystem that will have been degraded, damaged or destroyed due to the construction of Corridor 4. Passive restoration actions may include fencing and signing sensitive areas during construction, which will minimize construction impacts. Active restoration actions include soil decompaction, revegetation, removal formal or informal trails out of sensitive area. These actions will accelerate ecosystem recovery and promote the health and longevity of the Panagal Park.

133. In addition to the compensatory plantation, green belt area can be developed for the total length of elevated corridor using native shrubs, herbs and grasses. A central ribbon area will be planted with small tree species which grows up to height of 4-5 m. The peripheral ribbons will be planted with grasses and perennial herbs interspersed with medicinal plants like Tulasi, Vinca, Evolvulus, Hemidiscus etc. Appropriate shade loving and light loving trees could be preferred depending on the location. In a case study of green belt in cement industry in India, ambient concentrations of SO₂ was found to reduce by 39%, NO_x by 40%, SPM by 37%, THC by 86%, CO by 93%, VOCs by 87.1% across the green belt and the overall air pollutant removal efficiency was calculated as 63% (Assessment of Carbon Sequestration Ability of Trees for Adopting in Green Belt of Cement Industries in Karnataka, March 2016, Central Pollution Control Board Zonal Office South). Thus the green belt will provide aesthetic view of elevated track and also helps to serve as dust and noise absorbent barrier.

134. Efforts will be made to minimize the cutting of trees by transplantation of the young trees. Transplantation will be done in coordination with the forest department.

5.2.3 Loss of Biodiversity

135. CMRL will obtain the CRZ clearance from TNCZMA prior to contractor's mobilization. CMRL will ensure the compliance of the general conditions and specific conditions set forth in the CRZ clearance.

136. Corridor 4 passes through Panagal Park which is a community park; underground station is proposed underneath with access on roads at its periphery. The station will be constructed by cut and cover, loss of trees and birds and animals dependent on trees will be dislocated. Lighting at Panagal Park Metro station will be kept to the minimum and of frequencies and brightness which do not affect bird behavior. Construction and operation of the metro viaduct on these sections could disturb nesting and breeding due to noise.

137. Artificial Light at Night (ALAN) has been linked to important maladies such as cancer incidence and reduced skeletal muscle function. Effects of ALAN on wildlife have been recorded: influences on nest site selection by sea turtles, changes in the diversity and behavior of nocturnal moths, and alterations to ecological interactions of insects. Trees in close proximity to sources of artificial lights budburst earlier than trees away from lights. In birds, a positive phototaxis effect (attraction to lights) resulting in high mortality due to collision with illuminated buildings and windows. More subtle effects of light pollution on birds are also known, such as disorientation, alterations in reproductive physiology, disruption of circadian rhythms, and changes of flight behavior (Light pollution is greatest within migration passage areas for nocturnally-migrating birds around the world, Sergio A. Cabrera-Cruzetal, Scientific Reports volume 8, Nature). Independently the elevated structure could impede flight of birds.

5.2.4 Impacts on Utilities

138. Corridor 4 is planned to run through the urban area above the ground i.e. elevated in less densely populated and underground in populated and sensitive areas. The alignment will cross drains, large number of sub-surface, surface and utility services, viz. sewer, water mains, storm water drains, telephone cables, overhead electrical transmission lines, electric pipes,

traffic signals, roadside lights etc. These utilities/ services are essential and have to be maintained in working order during different stages of construction by temporary/permanent diversions or by supporting in position.

139. The Organizations / Departments responsible for concerned utility services are reported in Table 5.2.

Table 5-2: Organizations Responsible for Utilities and Services

S.no	Organization/ Department	Utility/Services
1.	PWD / Chennai Municipal Corporation	Road
2.	Chennai Municipal Corporation/ Chennai Metro Water Supply and Sewerage Board (CMWSSB)	Sewerage and drainage lines. Water mains and their service lines, including hydrants and fountains etc., water treatment plants, pumping stations, Roads, surface water drains, nallahs, sewer lines, streetlights, high mast lights etc.
3.	NHAI	National Highways
4.	TNHD	State Highways
5.		
6.		
7.	BSNL (OFC and Telephone Cables)	Tele cables, junction boxes, telephone posts, O.H lines
8.	Airtel, Vodafone, Idea, Jio	Telecommunications cables, junction boxes, telephone posts, etc.
9.	Power Grid Corporation of India Ltd.	HT towers, cables
10.	Irrigation Dept.	Canal
11.	BPCL	Gas pipelines
12.	Gas Authority of India (GAIL)	Gas pipelines
13.	Chennai Corporation and Tamil Nadu Generation and Distribution Corporation Limited (TANGEDCO)	HT/other overhead Power lines

140. During construction phase there will be great amount of issues encountered for the utility system/infrastructure facilities already existing within the alignment. The most important and hazardous aspect will be pipelines network running along the alignment. A decision has to be taken regarding encasing these pipelines as shifting/relocating will be of great inconvenience to the residential areas. Also it is a hazardous operation of relocation and therefore a proper HAZOP study (& risk analysis) has to be conducted by contractor and CMRL during pre-construction period for any kind of handling of this issue in concurrence with gas supply agency. The similar study has to be conducted for water supply and high tension lines with the concurrence with concern agencies.

141. The alignment of the metro will negotiate a number of utilities which will have to be maintained in working order during construction. They may require temporary or permanent diversion subject to their depth, details such as piling configuration or span of viaduct, utility protection measures, etc. Utility lengths to be diverted are as follows: sewer and water supply lines (depth 2.5m below ground) 3,420m and 15,000m between Lighthouse and Meenakshi College, and Power House and Poonamallee Bypass respectively; telecom cables (depth 1m to 4m below ground) 40,919m and 185,990m respectively; above ground HT/LT electric cables 22,888m Power House and Poonamallee Bypass.

142. Delayed approvals and diversion of utilities can affect construction schedule while damage to utilities can cause disruption to essential services to the citizens. Ahead of start of construction on the respective sections, diversion plans will have to be prepared based on

updated location drawings and concurrence of respective agencies. Preferably they will have to be diverted by the agencies themselves.

143. Span and pile arrangement of the viaduct may be suitably adjusted to ensure that pier foundations do not foul with major underground utilities. They will be diverted either temporarily or permanently before or during construction in those sections where the alignment cannot be fine-tuned to avoid conflict with utilities

5.2.5 Impacts on PCRs

144. No archaeological monuments / sites are located on the project corridor. The following three assets are located within 75m from the alignment.

Table 5-3: Heritage assets near the alignment

No	Name of heritage asset	Approx. distance from road followed by the alignment (m)
1	National Shrine of St. Thomas Basilica, Santhome High Road, Santhome	1
2	Rosary Church, Rosary Church Road	1
3	Our Lady of Light Shrine, Luz Church Road	73

145. The alignment will be fine-tuned, if feasible, to steer away from heritage assets on Corridor 4.

146. Since the project involves cut & cover, and piling for piers there are possibilities that contractor may encounter artifacts during piling operation. Chance find measures are included in the EMP to minimize the impacts on historical / archeological artifacts, in case found during excavation work. CMRL will inform and coordinate with Archaeological Survey of India if any ancient remains are encountered during construction work.

147. In locations where alignment is within 75m (as per the reference distance of acceptable vibration impacts) to historical/heritage structures, the contractor shall prepare a monitoring scheme prior to construction at such locations. This scheme for monitoring subsidence and vibration level at such historical / heritage sites shall be submitted to CMRL for approval. The scheme shall include:

- Monitoring requirements for vibrations at regular intervals throughout the construction period.
- Pre-construction structural integrity inspections of historical / heritage / sensitive structures in the project area, especially for any buildings the TBM will pass nearby.
- Information dissemination about the construction method, probable effects, quality control measures, and precautions to be used.

148. The vibration level limits at work sites adjacent to the alignment shall conform to the permitted values of PPV.

5.2.6 Climate Vulnerability

5.2.6.1 Sea level rise due to climate change

149. Vulnerability of project to rise in mean sea level (submergence) and high tide level (degradation) on the project is indicated in Figures 5.1 and 5.2. Belt of width approx. 0.5 km of beach and developed area on alignment between Lighthouse and Kutchery Road is underground and can be subject to flooding disrupting operations. On Corridor 4, flooding gates and other adequate facilities will be made in terms of evacuation of flood water using pumps in Lighthouse, Foreshore Road stations. Disaster management plan will pay special attention to flooding.

Figure 5-1: Predicted MSL and HTL in Chennai Sector

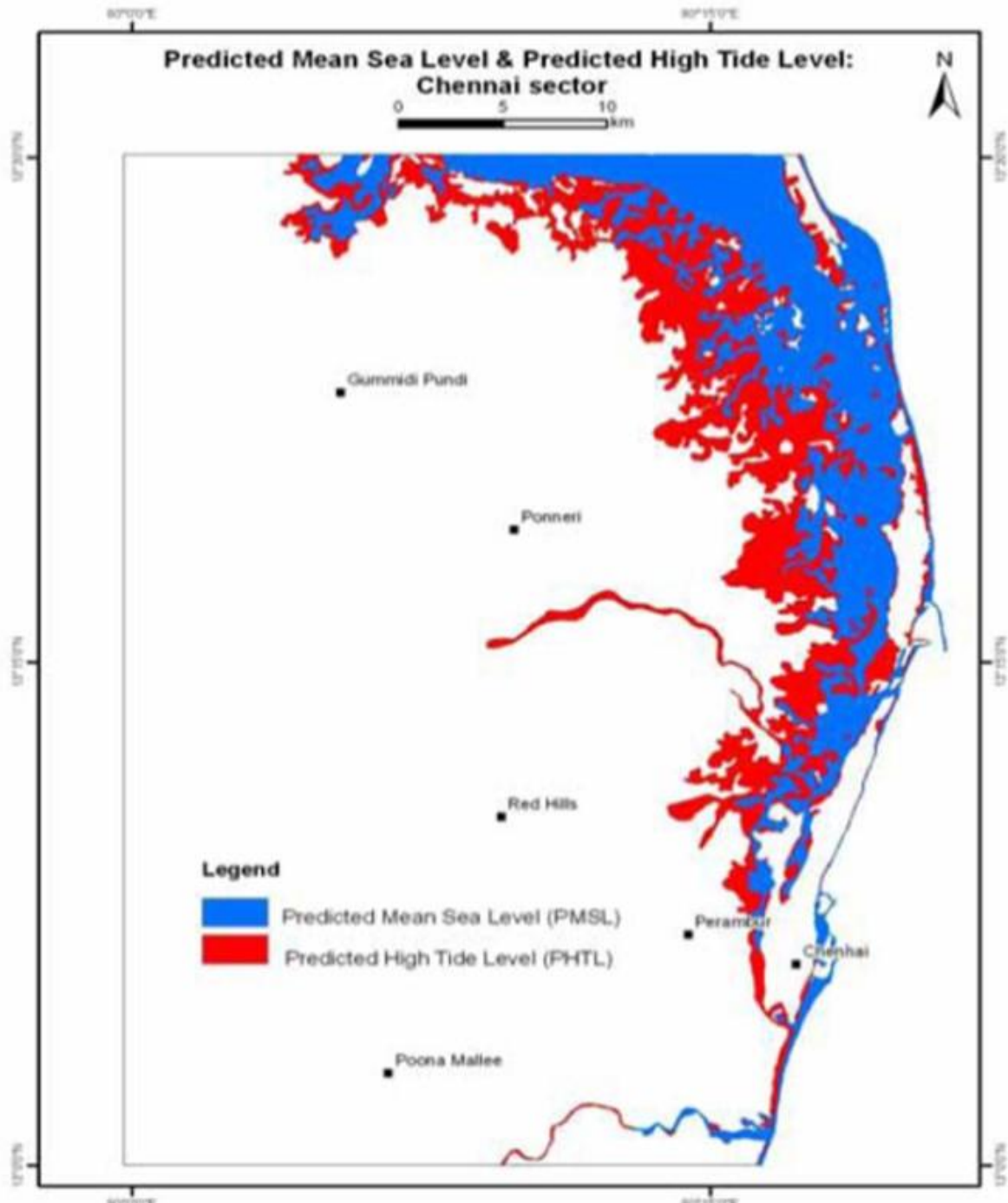

Source: Coastal Zones of India, SAC ISRO- MoEF&CC, 2012

5.2.6.2 Flooding resulting from Anomalous Heavy Rainfall

150. In year 2015 Chennai was flooded due to exceptionally heavy rainfall. Flooding was observed in areas adjoining Adyar river though lesser along Cooum river. Most of the alignment of Corridor 4 is not located near these rivers¹⁷ and therefore flooding is not a likely impact. Figure 5.2 depicts the inundated areas.

¹⁷Proposed Adyar gate Junction station is about 600 meters away from Adyar River, according to figure 5.2 that area had up to 3.5 feet of water during the 2015 floods.

Figure 5-2: Chennai Flood map 2015

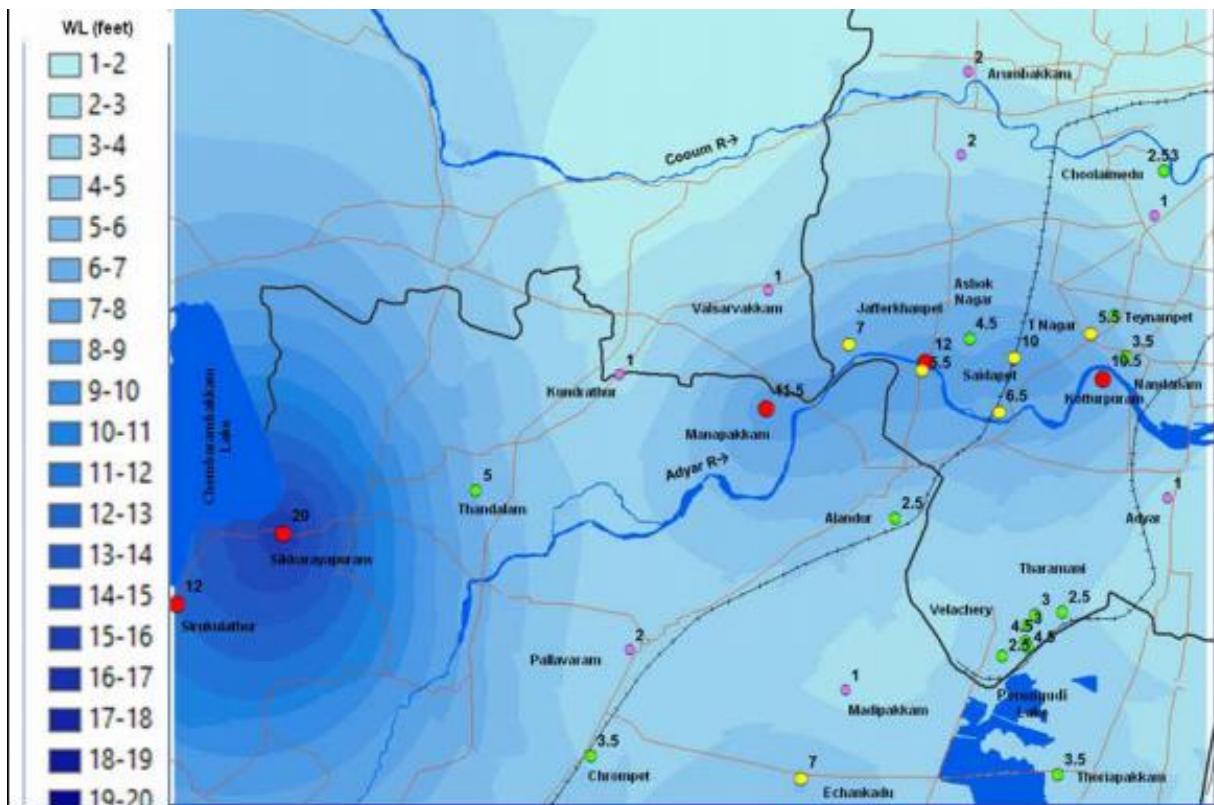

Source: Chennai Floods, 2015 A Satellite and Field Based Assessment Study, Disaster Management Support (DMS) Division National Remote Sensing Centre (NRSC / ISRO) Hyderabad, India

5.2.6.3 Risk Due to Earthquake

151. Although Chennai is located in Moderate Seismic Zone, different parts of Chennai have variable potential for seismic hazard. Corridor 4 is located in moderately to above moderately vulnerable seismic micro zones.

152. Design of line structures – tunnel and viaduct – and station shall be done to facilitate robust safety and quicker evacuation. Stipulation of Bureau of Indian Standards engineering codes shall be met while designing the structures while taking into account micro zonation of Chennai in terms of seismic risk.

5.2.7 Operational Noise and Vibration

153. As part of the detailed design a noise and vibration modeling and assessment along the alignment should be conducted prior to start of construction by CMRL and contractor. At sensitive receptor locations within 50 m along the alignment (where operational stage noise level is expected to be higher than permissible limits). Appropriate mitigation measures including possibilities of installing noise barriers at sensitive receptor locations shall be determined by CMRL and contractor and agreed by MDBs.

5.3 Impacts and Mitigation Measures During Construction Phase

154. Although environmental hazards related to construction works are mostly of temporary nature. Appropriate measures should be included in the work plan and budgeted for. The most likely negative impacts related to the construction works are:

- Storm water drainage and topsoil erosion
- Traffic diversion and risk to existing building

- Air pollution due to dust generation
- Noise and vibrations
- Increased energy demand and impacts on Water
- Impact due to supply of construction material
- Disposal of construction and demolition waste
- Disposal of Hazardous Waste
- Dewatering of Excavations
- Ground subsidence
- Dewatering
- Impacts due to batching plant and casting yard
- Impacts of labour camps
- Health and Safety

5.3.1 Soil Erosion Impact

155. Change in land use and excavation of soil will lead to soil erosion. Every care has to be taken to avoid damage to the topsoil (more specific) from median, and depot site topsoil. It has to be preserved and utilized. Problems could arise from dumping of construction spoils (concrete, bricks) waste materials (from contractor camps) etc. causing surface and groundwater pollution.

156. Corridor 4 will have elevated track and there are 12 elevated stations. Soil excavation will be required for piling activities for metro piers. Muck from tunneling containing Bentonite would also be generated in the project.

157. Mitigation measures: The excavated soil would be used for refilling at station site but muck from piling work will be disposed at locations/sites approved by Tamil Nadu Pollution Control Board. Responsibility of disposal of this soil will lie with contractor and will be regulated by TNPCB rules. Disposal of Bentonite would be at designated landfill site.

158. The construction activities will cause soil erosion during excavation. This can be mitigated by utilizing around 35 % of excavated soil for land filling purposes. The excavated top fertile soil is suggested to be preserved and used later for gardening and lawn establishment. Soil erosion by runoff will be controlled by installing proper drainage systems using contour information.

159. Subject to specifications issued by CMRL in the works contracts, the earth excavated during cut and cover and tunneling and displaced during piling will be used as backfill on the project. Such backfill will result in estimated surplus quantity of 0.94 million cum from Corridor 4. If this muck is not contaminated by hazardous substances such as heavy metals or POPs¹⁸, the contractor will be permitted to sell it as fill for activities outside the project; in case of hazardous contamination it will be disposed at permitted sites by licensed vendors.

160. Sites for muck disposal will be decided by CMRL before start of construction in consultation with TNPCB, Municipal Corporation/Municipalities and CMDA. The sites will be located away from residential areas, water bodies and ecologically sensitive locations as to avoid disrupting natural drainage.

161. Material will be stabilised by watering or other accepted dust suppression techniques. The muck shall be filled in the dumping site in layers and compacted mechanically. Suitable slopes will be maintained on the stockpile. Once the filling is complete, it will be protected by

¹⁸Methods Manual of Soil Testing in India from Ministry of Agriculture or any other internationally recommended guideline/standards will be used for the soil investigation.

low walls, provided with a layer of good earth on the top and covered with vegetation. A muck disposal plan will be prepared by Contractor, which will be approved by CMRL.

5.3.2 Traffic Diversion and Risk to Existing Buildings

162. During construction period, complete/partial traffic diversions on road will be required, as most of the construction activities are along the road. In order to retain satisfactory levels of traffic flow during the construction period, traffic management and engineering measures need to be taken. They can be road widening, traffic segregation, one-way movements, traffic diversions, acquisition of service lanes, etc.

163. Preparation of Traffic management Plan and maintenance of diverted roads in good working condition to avoid slow down and congestion shall be a prerequisite during construction period.

164. Various construction technologies are in place to ensure that traffic impedance is done at the minimum. They are:

- The requirement would be mainly along the central verge/ side of the road
- As regards to the alignment cutting across a major traffic corridor, 'Box Girder Construction Technology' would be applied to prevent traffic hold-ups or diversions of any kind
- Cut and cover at underground stations will be employed to ensure that traffic impedance is minimized

165. **Traffic Management Guidelines:** The basic objective of the following guidelines is to lay down procedures to be adopted by contractor to ensure the safe and efficient movement of traffic and also to ensure the safety of workmen at construction sites. The Contractor shall develop detailed and robust traffic management plans consistent with the Indian Roads Congress (IRC) on Traffic Management in work zones (IRC:SP:55-2014), prior to mobilization for respective sections with site- or station-specific plans and measures to minimize the overall impact on traffic throughout the construction and operation periods.

- All construction workers should be provided with high visibility jackets with reflective tapes as most of viaduct and station works are on the right-of-way. The conspicuity of workmen at all times shall be increased so as to protect from speeding vehicular traffic.
- Warn the road user clearly and sufficiently in advance.
- Provide safe and clearly marked lanes for guiding road users.
- Provide safe and clearly marked buffer and work zones
- Provide adequate measures that control driver behaviour through construction zones.
- The primary traffic control devices used in work zones shall include signs, delineators, barricades, cones, pylons, pavement markings and flashing lights.
- Advance traffic updates/ information on communication systems for users of affected roads.
- Efforts will be given to divert traffic to roads wide enough to accommodate extra traffic.
- Incorporation of community safety considerations into plan design, especially at locations such as Kutchery Road where buildings are close to the construction site.

166. Corridor 4 does not pose any serious risk to existing buildings since there is safe distance between buildings and proposed alignment except at a few shops the alignment is passing over the temporary shops. Here special care has to be taken for safety of the structures during construction when they will be shifted for short duration.

5.3.3 Air Pollution

167. The major sources of ambient air pollution are demolition of structures to be removed; operation of construction equipment; installation of earth retaining structures, pile driving where cast-in-situ is not feasible, blasting in rock; movement of vehicles transporting construction materials, muck and waste. The pollution is in terms of fugitive dust and emissions from trucks.

168. Trucks are required to transport raw material to casting yards and Ready Mix Concrete (RMC) plants; from pre-cast yards and batching plants to construction site and between construction site and muck/waste disposal site. Vehicular emission is estimated as in Table 5.4.

Table 5-4: Emissions due to truck movement during demolition and construction

Pollutant	Emission (ton)
Carbon Monoxide (CO)	63.00
PM _{2.5}	2.0
Hydro-Carbons (HC)	2.0
Nitrogen Oxide (NO _x)	131.0
VOC	20.0
Carbon dioxide (CO ₂)	8145

169. Emissions from DG sets, pollution at sites of waste disposal and muck disposal during unloading and stacking, emissions from fuel and other hazardous chemicals are among other sources of air pollution.

170. Air pollution from road based vehicles especially particulate is found to cause diseases of brain, heart, lungs and kidneys.

171. Mitigation measures which will be adopted to reduce the air pollution are listed below:

- Contractor's transport vehicles and other equipment shall conform to emission standards. The Contractor shall carry out periodical checks and undertake remedial measures including replacement, if required, so as to operate within permissible norms.
- Procedure for truck maintenance, including selection of service providers considering environmental aspects, application of low-Sulphur fuel, no idling of trucks, routine maintenance (including assurance of proper engine operations related to emissions and noise), and disposal of used oil and other fluids, batteries, and tires etc.
- DG sets compliant with emission standards will be used
- The following dust protection methods will be used:
 - Dust screens during excavation and demolition near sensitive receptors
 - Dust filters atop cement silos
 - Wet suppression for aggregate crushing and screening
 - Good quality project roads with added petroleum emulsions and adhesives, speed control, traffic control.
 - Material of specifications as per contract will be procured by Contractor from Government-approved quarries
- The Contractor will ensure that trucks carrying loads of sand and aggregate required in construction being transported to construction yards are covered and loaded with sufficient free - board to avoid spills--within the largest compartment of tanker truck. Transportation will be scheduled by time and route to minimize air pollution in habitat areas.
- The Contractor will ensure that the authorized vendor covers loads of construction and demolition (C&D) waste and hazardous waste being transported from construction sites. All trucks carrying loose material should be covered and loaded with sufficient free -

board to avoid spills through the tailboard or sideboards. Containers carrying hazardous waste are loaded onto trucks with due care to avoid escape of fumes or spillage enroute. Transportation of muck and waste will be scheduled by time and route to minimize air pollution in habitat areas. The contractor will implement similar safeguards while transporting muck.

- The temporary muck storage areas will be maintained by the Contractor at all times until the excavate is re-utilized for backfilling or as directed by GC. Dust control activities will continue even during any work stoppage. Soil erosion by runoff will be controlled by installing proper drainage systems using contour information. It is suggested to avoid bringing soil from outside the project boundary and to use the excavated mounds for filling low lying area where it is necessary.
- The Contractor will provide a wash pit or a wheel washing and/or vehicle cleaning facility at the exits from construction depots and batching plants. At such facility, high-pressure water jets will be directed at the wheels of vehicles to remove all spoil and dirt.
- Construction yards with aggregate crushing and screening, pre-casting, material and fuel storage and GC plants will be located away from habituated or ecologically sensitive areas.
- Labour residing in camps will be provided with LPG fuel for cooking.

5.3.4 Noise and Vibrations

172. Noise is a contributing factor to degradation of human health. The noise pollution will be generated by construction activities, mainly due to demolition of structures to be removed; installation of earth retaining structures; pile driving where cast-in-situ is not feasible; blasting in rock etc., and also due to the construction equipment if they are not in maintained condition. Also during such activities if existing vehicular traffic is not properly diverted then congestion and then continuous honking habits will also lead to incremental noise levels which are of indirect nature. This will also pave way for vehicular air pollution which is also to be minimized effectively. Corridor 4 construction is equipment intensive.

5.3.4.1 Noise Due to Operation of Construction Equipment

173. The major sources of noise during construction phase are due to operation of various construction equipment. Permitted number of impacts (example piling) at various noise levels is prescribed under Model Rules of the Factories Act, 1948. Actual noise from construction equipment (Lmax) measured at 50 feet distance (*Construction Noise Handbook August 2006, FHWA, USA*) ranged from 76 dB(A) to 84 dB(A); vibratory pile driver at 101 dB(A). The noise levels generated by various construction equipment are given in Table 5.5.

Table 5-5: Average Noise Levels Generated by Operation of Various Construction Equipment

Equipment	Typical Noise Level (dBA) at 50 ft from source
Air Compressor	81
Backhoe	80
Ballast Equalizer	82
Ballast Tamper	83
Compactor	82
Concrete Mixer	85
Concrete Pump	82
Concrete Vibrator	76
Crane Derrick	88
Crane Mobile	83
Dozer	85

Equipment	Typical Noise Level (dBA) at 50 ft from source
Generator	81
Grader	85
Impact Wrench	85
Jack Hammer	88
Loader	85
Paver	89
Pile Driver (Sonic)	96
Pneumatic Tool	85
Pump	76
Rock Drill	98
Roller	74
Scraper	89
Shovel	82
Truck	88

Source: FTA Transit Noise and Vibration Guidance Handbook, May 2006

Equipment	Actual Lmax Noise Level (dBA) at 50 ft from source
Auger drill rig *	84
Compressor *	78
Dump truck *	76
Excavator *	81
Flatbed truck *	74
Front end loader *	79
Vibratory Pile driver *	101
Press Pile	70
Batching Plant	90
Booster pump	80

* Source: Construction Noise Handbook, US FHWA, Aug 2006

5.3.4.2 Noise due to increased vehicular movement

174. During construction phase, there will be significant increase in vehicular movement for transportation of construction material. In addition to the noise mentioned above, there will also be background noise of the usual traffic resulting due to traffic congestion. Efforts should be made to keep the noise levels under control by appropriate noise attenuation and adopting employee safety measures. Temporary route direction markings will be placed in appropriate locations. During construction phase, the increase in vehicular movement is expected to increase up to a maximum of 5 to 6 trucks/hour. Table 5.6 presents the typical increase in ambient noise level due to increased vehicular movement if the background noise level is at 36dB(A),

Table 5-6: Increase in Noise Levels Due to Increased Vehicular Movement

Distance (m)	Ambient noise level dB (A)	Increase in noise level due to increased vehicular movement dB (A)
10	36	72
20	36	67
50	36	61
100	36	57
200	36	52

500	36	46
1000	36	42

5.3.4.3 Impacts of Noise on Labour

175. The effect of high noise levels on the operating personnel has to be considered as this may be particularly harmful. It is known that continuous exposures to high noise levels above 90 dB(A) affects the hearing acuity of the workers/operators and hence, should be avoided. To prevent these effects, it has been recommended by Occupational Safety and Health Administration (OSHA) that the exposure period of affected persons is limited (Table 5.7).

Table 5-7: Maximum Exposure Periods Specified By OSHA

Maximum equivalent continuous Noise level dB(A)	Unprotected exposure period per day for 8 hrs/day and 5 days/week
90	8
95	4
100	2
105	1
110	½
115	¼
120	No exposure permitted at or above this level

176. To reduce the harmful effects, personnel working at high noise levels would be provided with noise protective gears such as ear mufflers, sound barriers etc. Vehicles used for transportation of construction materials would be equipped with silencers. Careful planning has been made to operate the construction equipment to have minimal disturbances. The construction equipments will be in use during the daytime and their noise levels would be monitored as per CPCB standards. Besides other measures such as use of low-noise equipment and ensuring good maintenance, trying to avoid using high-noise equipment simultaneously at the same section etc. will also be implemented to minimize construction noise.

177. Exposure of workers to high noise levels will be minimized by measures such as the following:

- Personal protective equipment such as passive or active ear-muffs
- Use of electric instead of diesel powered equipment
- Use of hydraulic tools instead of pneumatic tools
- Acoustic enclosures for noise generating construction equipment like DG sets
- Scheduling work to avoid simultaneous activities that generates high noise levels
- Job rotation
- Sound-proof control rooms
- Automation of equipment and machineries, wherever possible.

5.3.4.4 Predicted Noise Level during Construction Stage

178. Noise modelling during construction phase was carried out using CPCB/ MoEF&CC approved noise model “DHWANI” assuming that all the equipment emit noise simultaneously considering as worst-case scenario. The spatial variation of the predicted noise levels at an interval of 5 dB(A) without control around the project site on the area of 1 km x 1 km are shown in Figure 5.3. Modelling result shows that noise level meets the Ambient Noise Quality Standards (ANQS) 55 dB(A) (average between 6 am to 10 pm) at a distance of about 900m.

Figure 5-3: Spatial Variation of Construction Equipment Noise Levels dB(A)

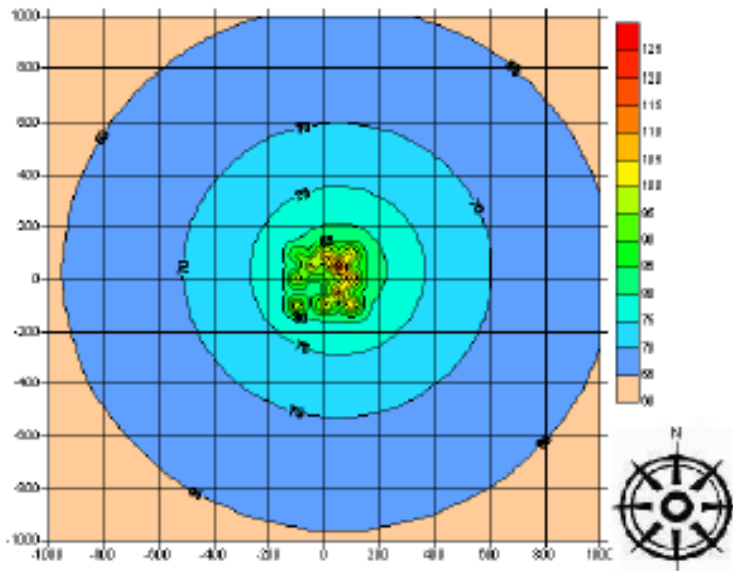

Uncontrolled noise levels generated from construction equipment, in the range of 94-124 dB(A) have been considered for prediction purpose. However, the CPCB standards specify to limit the construction equipment to ensure that noise emission specifications for such equipment should not exceed 75 dB(A). The noise levels predicted here is without mitigation measures. It is assumed that with the adoption of the mitigation measures noise levels will be further restricted within very short distances from the source. With respect to occupational exposure, the permissible threshold is 90 dB(A) (continuous exposure over 8

hours). Thus, based on the modelling results it can be concluded that all sensitive receptors (i.e. labour colonies) should be located beyond 125 meters from the noise generating source location during construction activities.

179. Further noise modelling will be conducted, based on the detailed engineering design to inform the incremental impacts and suggest the mitigations accordingly.

5.3.4.5 Vibration during Construction Stage

180. Pile driving for viaduct piers and buildings and tunnel driving generate vibrations. Apart from distance from the alignment, age and condition of buildings adjacent to the alignment determines extent of damage to such buildings due to vibration. Continuous effect of vibration on the buildings can cause damage to buildings. Buildings subjected to the vibration of more than 150 VdB might be subjected to structural damage. Historic buildings are more susceptible to vibration effect due to type of building material and design. Corridor 4 is located in moderately to above moderately vulnerable seismic micro zones.

181. In order to evaluate the construction stage vibration levels from the project construction activities, the Construction Vibration Damage Criteria set by FTA for different building category is referred in Table 5.8 below.

Table 5-8: Construction Vibration Damage Criteria as per FTA guidelines

Building Category	PPV (in/s)	PPV (mm/s)	Approximate Lv, RMS velocity in decibels (VdB) re 1 µin/s.
I. Reinforced-concrete, steel or timber (no plaster)	0.5	12	102
II. Engineered concrete and masonry (no plaster)	0.3	7.6	98

III. Nonengineered timber and masonry buildings	0.2	5	94
IV. Buildings extremely susceptible to vibration damage	0.12	3	90

182. During construction of the underground section, TBM will be used. With a tunnel depth of approximately 25 m (vertical distance between tunnel top and floor of building above ground), the expected vibration level during operation of the TBM is approximately 99VdB in conditions of sandy and clay soil which is dominant in the project area. Attenuation of vibration is expected to be about 16 VdB resulting in a net vibration at the ground floor of the building above ground to be about 83 VdB.

183. According to the FTA manual the threshold level of vibration for beginning to cause annoyance to human beings is about 75VdB and for causing damages to extremely fragile structure is about 90 VdB. Given that the expected vibration level at the ground floor is about 83 VdB, people living in the ground floor of houses located immediately above the tunnel will feel the vibration and may get annoyed when the TBM is operational. However, it is unlikely that any structural damages will take place.

184. In the case of vibrations from road traffic and pile driving, very deep barriers (in excess of 10 m) were found to reduce vibration. In-ground barriers are trenches that are either left open or filled with a material (such as bentonite or concrete) that has stiffness or density significantly different from that of the surrounding soil. However, trenches may be too costly for situations involving houses. They could perhaps be justified for larger buildings with strict vibration limits, such as operating theatres of hospitals or high-tech factories with sensitive processes. An economical alternative to trenches in a residential area could be a row of lime or cement piles of diameter 0.5 m to 1 m and a depth of 15 m in the right-of-way adjacent to the road. However, the effectiveness of such pile-walls has not yet been demonstrated¹⁹. Cast-in-situ piling will be deployed at locations with sensitive receptors so as to reduce vibration. At locations where the alignment is close to sensitive receptors, the contractor shall implement:

- The detailed noise and vibration analysis (mathematical modelling) at sensitive receptors based on final engineering designs should be carried out, based on which, a set of mitigations should be prepared and shared with all lenders for review, prior to commencement of construction
- Pre-construction structural integrity inspections, including visual inspections of buildings of cultural or historical significance
- The sensitive receptors have to be isolated from heavy construction noise generated. This is possible by erecting reinforced 2 m tall GI sheet barrier around the area where heavy construction works is undertaken
- Information dissemination about the construction method, probable effects, quality control measures and precautions
- Monitoring during construction

185. Further vibration modelling will be conducted, based on the detailed engineering design to inform the incremental impacts and suggest the mitigations accordingly.

5.3.5 Increased Energy Demand and Impacts on Water

5.3.5.1 Increased Energy Demand

¹⁹NRC-CNRC Construction Technology Update No. 39, 2000, Vibrations in Buildings by Osama Hunaidi and A review on the effects of earth borne vibrations and the mitigation measures, BOO Hyun Nam et al, IJR International Journal of Railway, Sept 2013.

186. Construction employs energy intensive equipment round the clock. High illumination lighting and minor tools and equipment impose increased demand on energy consumption due to construction.

187. The contractor shall use and maintain equipment so as to conserve energy and shall be able to demonstrate the abovementioned upon request of CMRL. Measures to conserve energy include maintenance of energy efficient tools, plant and equipment of; lamps and DG sets to comply with TNPCB norms; Promoting awareness through energy saving trainings.

5.3.5.2 Increased Water Resource and Quality

188. The water demand will increase during construction phase for meeting out drinking and domestic water requirement of workers. Sufficient water for construction purpose would be made available from CMWSSB supply, or treated effluent from ETPs located nearby or seawater or surface run off in view of the quality requirements of construction based contractor-defined estimated volumes. Water consumption during construction is of the order of 433 KLD for Corridor 4.

189. Construction materials, oils and greases from construction sites; used water from the RMC plant; water used for dust suppression at aggregate crushers are sources of pollution of surface water bodies or groundwater. Sewage from labour camp can also pollute surface water bodies or groundwater. Groundwater which seeps into excavations can get contaminated by chemicals used in construction and consequently pollute groundwater outside the excavations upon dewatering. This water will be treated to meet CPCB standards and added to groundwater to recharge.

190. Wastewater from labour camps, construction sites and construction yards will be treated by means including precipitation chambers before disposal into sewage system. Dewatered water will be used for dust suppression purpose, and the remaining will be suitably treated before recharging groundwater or discharging into storm water drain.

5.3.6 Impact Due to Supply of Construction Material

191. Corridor 4 construction is a material intensive activity. Huge quantity of different construction materials will be required for construction of elevated section and stations. These shall be sourced from the nearest source. Quarry operations are independently regulated activities and outside the purview of the project proponent. It is, nonetheless, appropriate to give consideration to the environmental implications in selection of quarry sources since poorly run operations create dust problems, contribute noise pollution, ignore safety of their employees, or cause the loss of natural resources. So, the construction material shall be sourced only from legalized and approved quarries.

5.3.7 Disposal of Construction and Demolition Waste

192. Waste construction material, demolition waste and hazardous waste from construction equipment and construction vehicles can pollute air, water and soil. The procedure of demolition will be conducted as per the demolition plan prepared by the Contractor in consultation with CMRL. The existing structures should be demolished one after another cautiously.

193. C&D waste is part of solid waste that results from land clearing, excavation, construction, demolition, remodeling and repair of structures, roads and utilities. C&D waste has the potential to save natural resources (stone, river sand, soil etc.) and energy, its bulk which is carried over long distances for just dumping, its occupying significant space at landfill sites and its presence impedes processing of bio-degradable waste as well as recyclable waste. C&D waste generated from metro construction has potential use after processing and grading. The

contractor will segregate and temporarily store the C&D waste till the vendor takes it away for recycling and disposal at authorized facilities.

194. Mitigation Measures: The C&D waste would be handled and disposed of to waste processing facility or for back filling of low lying areas only if the area is covered afterwards with a good quality layer of topsoil of sufficient thickness, leaving no significant impact on environment. Bentonite slurries used in diaphragm wall construction should be reconditioned and reused wherever practicable. The disposal of residual used bentonite slurry should follow the international good practice.

5.3.8 Disposal of Hazardous Waste

195. Hazardous waste would mainly arise from the maintenance of equipment which may include used engine oils, hydraulic fluids, waste fuel, spent mineral oil/cleaning fluids from mechanical machinery, scrap batteries or spent acid/alkali, spent solvents etc.

196. The disposal of the hazardous waste should be as per the requirements given in the Hazardous Waste Management Rules 2016. The contractor will ensure that hazardous wastes from construction activity and equipment are labeled, recorded, stored in impermeable containment and for periods not exceeding mandated periods and in a manner suitable for handling storage and transport. The contractor shall maintain a record of sale, transfer, storage of such waste and make these records available for inspection. The contractor shall get Authorized Recyclers to transport and dispose Hazardous Waste, under intimation to the Project Authority.

5.3.9 Ground Subsidence

197. Tunnel roof caving could cause ground subsidence above the tunnel resulting in settlement damage to structures on ground.

198. Proposed track depth is 18m to 20m; water table is between 1m to 10m; rock is available deeper than 20m between Kutchery Road and Thirumayilai stations, Adyar gate to Alwarpet, Kodambakkam suburban and Vadapalani and less than 20m depth at other locations on Corridor 4; soil is pervious (*source: geotechnical investigations along Corridor 4 in year 2016 and scheduled groundwater monitoring by Central Groundwater Board in years 2014 to 2016*).

199. During tunneling, material under pressure might come out of open borewells in the vicinity of the tunnel site resulting in ground subsidence beneath nearby structures (in case of Phase 1 Metro those within 16.5 m on either side of centerline of tunnel): therefore artesian wells and borewells in path of tunnel will be sealed. They will be permitted at least 3m on either side of the tunnel width, as in case of Phase 1 Chennai Metro.

200. Ground subsidence around tunnel sections could occur during tunneling due to ground water seeping into tunnel resulting in groundwater drawdown around the tunnel zone: such seepage along with existing water in tunnel will be removed ('dewatering'). Similar groundwater loss could occur during construction of underground stations by cut and cover. Groundwater drawdown will also temporarily reduce availability of groundwater for domestic consumption.

201. Groundwater extraction adjacent the metro project could lead to subsidence under non-metro structures as well as settlement of metro tunnel and stations between Kutchery Road and Thirumayilai stations, Adyar gate to Alwarpet, Kodambakkam suburban (rock deeper than track level). Therefore, it is recommended that locations of boreholes need to be rationalized to avoid groundwater extraction near tunnel.

202. Groundwater drawdown can be minimized by sealing joints in tunnel lining. In addition, where required adjacent structures will be given additional supports. Sides of deep excavations at stations will be supported by walls which minimize water seepage. In open areas where side support walls in excavations are feasible, such walls will help prevent caving and thereby settlement of adjacent structures; in built up areas where side walls are not feasible, adjacent structures will be provided additional supports.

203. Subsidence under nearby structures could occur due to strata disturbance and loss of bearing capacity of soil under foundations of nearby buildings: this shall be monitored and where required the structures will be provided additional support.

204. Caving of tunnel will be prevented by placing pre-cast concrete segments in soft soils and rock bolts or arch ribs in rock. Subsidence above tunnel due to removal of material and water beneath will be prevented by such tunnel supports

5.3.10 Dewatering of Excavations

205. Table 5.9 shows groundwater levels up to 10m below ground in pre-monsoon as well as post-monsoon seasons and rise in water level of up to 4m in 80% to 90% of observation wells in Chennai district between pre-monsoon and post-monsoon months. It indicates that significant dewatering of excavations might be required.

Table 5-9: Ground water level in Chennai District

Month/year	% of observation wells in each range of water level (m) below ground level			Rise (m) in water level	Fall (m) in water level
	0 to 2	2 to 5	5 to 10		
May 2013	8	54	38	60% wells <2m, 30% wells 2m to 4m	100% wells <2m
January 2014	36	36	29		
May 2014	14	33	53	50% wells <2m, 30% wells 2m to 4m, 20% wells >4m	Zero
January 2015	56	25	19		
May 2015	14	50	36	60% wells <2m, 30% wells 2m to 4m, 10% wells >4m	Nil
January 2016	41	47	12		
May 2016	24	59	17	83% wells <2m	86% wells <2m
January 2017	14	79	7		

(CGWB Yearbooks for Tamil Nadu and Puduchery)

206. The dewatering of tunnel muck will be conducted prior to transportation to the muck disposal site. The muck disposal plan will contain detailed requirements of such activity.

207. Chemicals used in tunneling could result in pollution of seepage water and further contaminate the groundwater or surface water into which this water is discharged: polyurethane resin used to seal water leaks through tunnel segments is toxic to aquatic life with long lasting effects (ECHA). Bentonite used to seal infiltration of water through soil is not classified as harmful. Polymers are used to facilitate tunneling in clayey soils. This water will be treated and added to groundwater to recharge.

5.3.11 Impacts Due to Batching Plant and Casting Yard

208. During construction phase there would be establishment and operation of Batching Plant and Casting Yard which would be located in an area designated and allotted by CMRL away

from habitation. If possible, these facilities will be located at least 500 m away from habitations and at least 1 km away from environmentally or ecologically sensitive area.

209. There would be significant movement of men, material and machinery in batching plant and casting yard. It is expected that both batching and casting yard would be located at same complex. Huge quantity of cement, aggregates and other construction materials would be used in batching plant and casting yard. There would be generation of dust, noise, flue gases and other contaminants from the working of heavy machinery for handling and transporting the construction materials. The mitigation measures for different aspects, such as the soil and groundwater quality baseline shall be collected by contractor prior to mobilization and shall be monitored during construction, have been elaborated in EMP.

5.3.12 Impacts of Labour Camps

210. During the progress of the work, the construction contractors work activities provides the erection and to maintain the necessary (temporary) living habitats and allied facilities for the workforce up to their living standards and scales up to be approved by CMRL. Improper disposal of municipal solid waste generated by labour camps can pollute surface water bodies and groundwater. Burning of waste can cause air pollution. Construction workers are more prone to infectious diseases due to unsafe sexual activity and lack of sanitation facilities (water supply and human waste disposal) and insect vectors. Problems could arise due to cultural differences between workers from outside and local residents.

211. Per Building & Other Construction Workers (BOCW Regulation of Employment and Conditions of Service) Act, 1996 the employer (contractor) is liable to arrange for sanitation, health care facilities of labours, free of charge. Labour camps will be in full compliance of BOCW Act.

212. It is estimated that about 4,284 persons will work during peak construction activity on 50% sections of the corridors on site, in casting yards and depots. Estimated total population in the labour camps will be 4,284. The water requirement at camps will be 578 KLD, wastewater generation 492 KLD & municipal solid waste generation 1.3 ton per day. This is tentative and will vary depending on the construction schedule during construction.

- **Water supply:** Uncontaminated water for drinking, cooking and washing, health care.
- **Sanitation Facilities:** Construction sites and camps shall be provided sanitary latrines and urinals. Sewerage drains should be provided for the flow of used water outside the camp. Drains and ditches should be treated with bleaching powder on a regular basis. The sewerage system for the camp must be properly designed by providing septic tanks, built and operated so that no health hazard occurs and no pollution to the air, ground or adjacent watercourses takes place. Garbage bins must be provided in the camp and regularly emptied and the garbage disposed in a hygienic manner. Labour camps should also be provided with proper ventilations and air cooling system.
- **Solid Waste Management:** Solid waste generated will have to be disposed in compliance with Municipal Solid Waste (Management & Handling) Rules, 2000, as amended to date. Municipal solid waste will be collected and taken away and disposed by municipality. Solid waste management facilities will be arranged by the construction contractors.

5.3.13 Health and Safety (H&S)

5.3.13.1 Occupational H&S

213. The construction works shall be undertaken in accordance with all applicable legislation and Indian statutory requirements and guidelines-OHSAS 18001-2007: Occupational Health

and Safety Management System/ ISO 45001:2018 and ISO 14001-2015: Environmental Management Systems.

214. Construction works shall be executed as laid down in the Environment, Social, Health and Safety (ESHS) Requirements applicable to Chennai Metro Phase 2. (**Annexure 5**)

215. While complying with this ESHS Requirements, site-specific and construction work-specific procedures for occupational health, safety and environment shall be prepared by the Contractor and approved by CMRL.

216. The mandatory requirements are as follows:

217. Legal requirements; Contractor's organisation and interfaces with CMRL; procedures to identify hazards and estimate risk, hazard mitigation measures; emergency response plan; arrangements for training, inspection, communication, compliance, reporting, documentation and audit; complaint address.

218. Guidance on occupational health, safety and environmental practices involved in construction on elevated, at-grade and underground works, with special focus as below,

- **Health care awareness and clinics:** Construction workers are more prone to Infectious diseases such as HIV/AIDS. It should be prevented by following actions: Counselling, community events, clinic, and coordination with local health authorities.
- **First aid facilities:** At every workplace, a readily available first-aid unit including an adequate supply of sterilized dressing materials and appliances shall be provided. Suitable transport shall be provided to facilitate taking injured and ill persons to the nearest hospital.
- **Day Crèche Facilities:** At every construction site, provision of a day crèche shall be worked out so as to enable women to leave behind their children. At construction sites where 25 or more women are ordinarily employed, at least a hut shall be provided for use of children under the age of 6 years belonging to such women. Huts shall be provided with suitable and sufficient openings for light and ventilation. Size of crèches shall vary according to the number of women workers employed.
- **Shelter at Workplace:** At every workplace, shelter shall be provided free of cost, separately for use of men and women labourers. Sheds shall be maintained in proper hygienic conditions.
- **Canteen Facilities:** A cooked food canteen on a moderate scale shall be provided for the benefit of workers wherever it is considered necessary. The contractor shall conform generally to sanitary requirements of local medical, health and municipal authorities and at all times adopt such precautions as may be necessary to prevent soil pollution of the site. Mobile anaerobic toilets (bio-digester based) will be provided.

5.3.13.2 Community H&S

219. During construction impacts on community H&S due to exposed to traffic, noise, dust and vibration disturbance and the risk of road traffic accidents are anticipated.

220. To prevent community H&S issues during construction, contractor on coordination with implemented measures such as provide the construction camps with facilities such as health care clinics, places of worship, and occasional entertainment, preparation of implementation of traffic management plan during construction, access to buildings, awareness and information sharing, and implementation of CMRL SHE Manual.

221. In case of road closure or traffic diversion, the Contractor will ensure that information on the timing of construction works and notifications of road closure (if any) is provided via local media (radio, TV, newspaper etc.) or through the local community heads.

5.3.13.3 COVID-19 Pandemic

222. WHO has declared COVID-19 as a pandemic which has affected entire world including India. In view of the prevailing COVID-19 pandemic, the Contractor and workers would need to take additional measures to avoid the spread of the disease and shall follow various guidelines/guidance notes issued by the national/state government, WHO, ILO, World Bank/IFC from time to time. As described in these guidelines, the Contractor shall undertake a COVID-19 risk assessment of project area and prepare a COVID-19 Response and Management Plan (C-R&MP) and submit to CMRL and GC for approval. A brief guidance on "To Do" List prepared from these documents is provided in the **Annexure 8**. Furthermore, the Standard Operating Procedures (SOPs) and Guidelines for Construction Sites for COVID-19 Outbreak developed by National Real Estate Development Council will be mandatory for contractors to follow.

5.4 Impacts and Mitigation Measures during Project Operation Phase

223. Positive Impacts: Key positive benefits are i) reduced air pollution, ii) increased employment opportunities, iii) improved economy, iv) mobility safety and reduced accidents, v) traffic congestion reduction, vi) reduced fuel consumption, vii) reduction in number of motorized vehicles, and viii) improvement of quality of life.

224. Negative Environmental Impacts: Along with many positive impacts, the following negative impacts during operation are anticipated:

- Noise and Vibrations
- Water supply and sanitation at stations
- Energy consumption at stations
- Pedestrianization and visual issues
- Health and Safety

5.4.1 Noise and Vibrations

225. Operation phase is extremely important from environmental issue viz. noise levels. The noise will be generated due to friction of the rolling stocks on the tracks which will generate incremental noise levels. The major noise level generating activities includes 1. Approach and breaking of rolling stocks 2. Rolling stock leaving from station, 3. During its travel between two stations and 4. Announcements on the Metro station.

226. The vibration is generally caused from rail-wheel interaction. This can be reduced by minimizing any surface irregularities on the wheel and rail. To minimize the vibration shock absorbing pad has to be provided and there has to be a distance between rail seat assembly and concrete plinth.

227. For elevated corridors, ballast less track structure is supported on two layers of rubber pads to reduce noise and vibrations. In addition, baffle wall as parapets will be constructed up to the rail level so as reduce sound levels. Noise at source will be controlled or reduced by incorporating suitable feature in the design of structures and layout of machines and by use of resilient mounting and dampers etc.

228. These noise generations for metro operation activities have been recorded from past experience from existing metro railways in India as well as project authorities. The following data includes various noise levels in above activities. During the operation phase the main source of noise will be from running of metro trains. Noise radiated from train operations and track structures generally constitute the major noise sources. Airborne noise is radiated from elevated structures. The noise level at 2m distance from the rail alignment is about 73 dB(A) which is higher than the CPCB permissible limit of 65 dB(A), and is much higher than the 50 dB (A) daytime limit for silence zone. The noise level reduces with distance logarithmically. Refer Tables 5.10 and 5.11.

Table 5-10: Exterior Noise Levels in Metro Stations

S. No	Description	Average Noise Levels dB(A)
		Elevated tracks
1	Background Noise Level	64.0± 1.5
2	Train entering the Platform (Max)	84.0± 1.5
3	Train leaving the Platform (Max)	84.0± 0.5
4	Train stopping in Platform	79.0± 0.0
5	Train stationary in Platform	76.0± 0.5
6	Train starting from Platform	78.5± 1.0
7	Train braking	86.0± 0.0
8	Announcement	74.0± 0.5
Overall		76.0± 7.0

Table 5-11: Interior Noise Levels in Metro Trains

S.No	Description	Average Noise Levels dB (A)
		Elevated tracks
1	Train stationary	62.0±1.0
2	Train starting	62.0±1.0
3	Train motoring	70.0±2.5
4	Train coasting	72.0±2.0
5	Train at max. speed	78.0±1.0
6	Train decelerating	69.0±0.5
7	Train stopping	64.4±1.0
8	Train braking	74.5±1.0
9	W/R Noise	75.0±1.5
10	Door operations (max.)	-
Overall		69.0±5.0

Source: Studies carried out by Central Road Research Institute (CRRRI) for metro projects in India

229. Noise barriers are recommended with noise reduction possibilities in Table 5.12.

Table 5-12: Noise Barrier for Noise Reduction

Place of Noise Barrier	Height of noise barrier	Noise reduction
On the viaduct in front of yard	4m (3.5m Absorptive+0.5m transparent) green color	15 dB(A)
On washing yard (s curve)	5m (Aluminium foam noise barrier) yellow color	17 dB(A)
On the back side boundary wall	3m (100% absorptive) blue color)	13 dB(A)
On the both sides of metro yard shade	3m (100% absorptive) blue color)	13 dB(A)

230. The study found that noise reduction is possible from 13-17 dB(A) after installation of noise barrier. Therefore, study suggested that noise barrier is the best option to reduce the instantaneous noise generated by metro; tree plantation is not a scientific option for reduction of noise levels.

231. Furthermore, the noise barriers consisting of 15mm thick UV coated clear transparent polycarbonate sheets meeting the criteria for acoustic performance as per EN 1793 and mechanical and structural performance as per EN 1794 including necessary structural

galvanized steelwork and rubber gasket all around, have been included in the tender document. The sound transmission class rating corresponding to sound attenuation of 30dB or above is required.

232. Elastic pad between seat of the rail and the track slab as well as between track slab and the superstructure beneath it will reduce vibration transmitted from the track and superstructure. Indicative pictures are shown in Figure 5.4.

233. The detailed analysis (computer modeling) of noise and vibration will be conducted based on the detailed engineering design, and will be finalized prior to contractor’s mobilization. The analysis will form the supplementary study of this EIA.

Figure 5-4: Vibration Damping Devices in Track

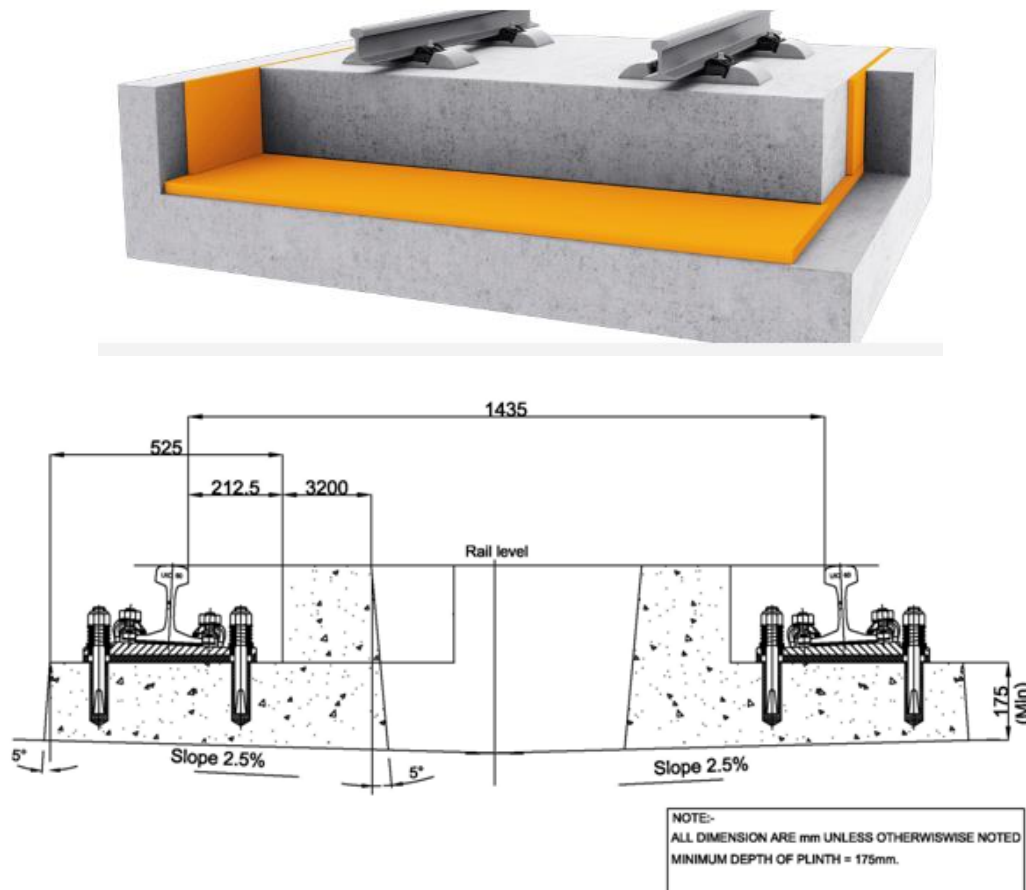

Source: Getzner Werkstoffe

5.4.2 Water and Sanitation Requirements at Stations

234. Public facilities such as water supply, sanitation and washrooms are very much needed at the stations. The water requirement for stations would be for drinking, toilets, cleaning and also for other purpose like Air Conditioning. Water Demand for alignment is calculated and presented in Table 5.13. The water requirement for the stations will be met through the public water supply system.

Table 5-13: Water Demand

S. No.	Particular	Water Demand at Each Station (KLD)	Total Water Demand (KLD)
--------	------------	------------------------------------	--------------------------

1	In Underground stations with softening plant	85.0	1,020
2	In Elevated stations	16.6	298.80
		Total	1,318.80

235. Thus there would be total water requirement of 1,318.8 KLD in 30 stations. Arrangement of water will have to be made at each station separately with proper drainage system for wastewater. CMWSSB water supply will be supplemented by rainwater harvesting along viaduct and rooftop of elevated stations. Sewage of 1,121 KLD will be generated. Wastewater will be led into municipal sewage system.

236. Solid waste generation from passengers at stations is likely to be 342 ton per day. Non-hazardous solid waste generated in stations will be collected and transported to the disposal sites by Chennai municipal corporation.

237. Mitigation Measures: Wastewater generated will be collected and discharged into municipal drains after proper treatment to meet the CPCB standards. Efforts should be made conserve the water by recycling water in the system. Also, as an environmental conservation measure, to conserve and augment the storage of groundwater, it is proposed to construct rainwater harvesting structure of suitable capacity at the elevated stations and in the elevated alignment. Each pillar can have inbuilt downpipes to collect the rainwater from the viaduct and rooftop of elevated stations and then led into underground tanks through layers of sand and gravel. At annual rainfall of 1,541mm, potential for rainwater harvesting is 2.80 lakh cum per year on Corridor 4.

5.4.3 Energy Consumption at Stations

238. Stations impose significant demands on energy. In addition, traction, rolling stock and train control systems also require reliable sources of grid and standby power, high intensity energy, as well as efficient equipment. Table 5.14 presents the power demand of alignment during operation.

Table 5-14: Power Demand

Load	2025		2035		2045		2055	
	Normal	Emergency	Normal	Emergency	Normal	Emergency	Normal	Emergency
3 km from Kilpauk GSS-Panagal Park RSS (Chainage -255 to 7436) 7.691km								
Traction	2.45	8.39	3.62	12.41	4.40	15.10	5.36	18.38
Auxiliary	11.67	19.95	14.58	24.40	16.32	27.46	17.49	29.62
Total	14.12	28.34	18.20	36.81	20.72	42.56	22.85	48.00
3.5 km from Koyambedu GSS-Avichi School RSS (Chainage -7436 to 25829) 18.38km								
Traction	5.94	8.39	8.79	12.41	10.70	15.10	13.02	18.38
Auxiliary	8.28	19.95	9.82	24.40	11.14	27.46	12.13	29.62
Total	14.22	28.34	18.61	36.81	21.84	42.56	25.15	48.00

239. Requirement of electrical energy for climate control, lighting and other facilities at stations will be optimized by proper use of natural day/night light and design of passenger flow inside stations and on streets outside stations. Installations for solar power will be implemented in stations where feasible. Full height platform screen doors will be implemented so as to conserve energy for ventilation and air conditioning in underground stations, which will also ensure passenger safety just as half height screen doors.

240. **Green Buildings.** In accordance with the GRIHA (version 2015) norms, the following measures will be implemented to a feasible degree in the stations and depots.

- Control annual heat gain through favourable orientation and design of facades
- Site planning according to contours
- Site plan designed to preserve existing vegetation/ existing water bodies / other topographical features like boulders etc.

- Manage storm water on site through rainwater harvesting
- Mitigate heat island effect by ensuring that building surface visible to sky is shaded by trees. Ensure zero SWD post-construction by means of ground water recharge and recharge of groundwater aquifers by rainwater. The building shall be designed to incorporate low ODP materials, indoor air quality and comfort, low-VOC paints and adhesives, reduced landscape water demand, sustainable building materials and renewable energy utilization etc.
- For the utilization of renewable energy, wherever feasible, installations for solar power can be implemented on roof of elevated stations. Installation and maintenance of solar power infrastructure is proposed to be awarded to developer along with Power Purchase Agreement (PPA). The power shall be purchased by CMRL on the basis of the unit rate specified by PPA.

241. In conformity to other corridors in Chennai, the following design elements are proposed which increase energy efficiency and safety:

- High voltage electric traction which have ability to carry high traffic at a reduced cost with higher efficiency of operation
- Rolling Stock is of light weight stainless steel / aluminium resulting in energy efficiency and improved life thus improving resource utilization and environmental quality. Standard Gauge rolling stock results in recurring saving in energy consumption during operation as for the same passenger carrying capacity, gross weight of a metro coach is lower.

5.4.4 Visual Issues

242. The introduction of metro system implies a change in streets through which it will operate. An architecturally well designed elevated section can be pleasing to the eyes of beholders. Recent metro rail projects have attempted to incorporate this objective in their designs. Since a low profile would cause the least intrusion, the basic elevated section has been optimized at this stage itself.

243. During design stage, the stakeholder engagement will be conducted to disclose the station designs and to incorporate the feedbacks.

5.4.5 Health and Safety

244. During operation accidents related to train operation like collision, derailment, fire, power outages, or operation stoppage may occur.

245. Detailed specification of equipment e.g. power cables, rectifiers, transformer, E&M equipment etc. shall be framed to reduce conducted or radiated emissions as per appropriate international standards. The Metro system as a complete vehicle (trains, signaling & telecommunication, traction power supply, E&M system etc.) shall comply with the Electromagnetic compatibility (EMC) requirements of international standards viz. EN50121-3-1, EN50123, IEC61000 series etc. EMC requirements of international standards for whole railway system to the outside world shall comply with EN50121-2.

246. Mitigation Measures: In the unlikely event of simultaneous tripping of all the input power sources or grid failure, the power supply to stations as well as to trains will be interrupted. A standby silent type DG set of adequate capacity at underground stations will sustain the following: essential lighting, signaling, and telecommunications, fire-fighting system, lift operation, and tunnel ventilation.

247. To provide a high level of safety with trains running at close headway ensuring continuous safe train separation, eliminate accidents continuous speed monitoring and automatic application of brake in case of disregard of signal / warning by the driver, and provides safety and enforces speed limit on section having permanent and temporary speed restrictions Automatic Train Protection and Automatic Train Supervision sub-systems will be installed.

248. CCTV system will provide video surveillance and recording function for the operations to monitor each station. The monitoring shall be possible both locally at each station and remotely from the operation control center.

249. In view of the potential hazards from system failure resulting to accidents, both on- site and off-site emergency measures will be implemented. All trains will have public address systems to warn the passengers of any emergency situation.

5.5 Impacts and Mitigation Measures Due to Depot

250. One major maintenance depot is planned on Poonamallee Bypass. Impacts and mitigation measures include:

- Water Supply
- Sewage/Effluent Treatment
- Rainwater Harvesting
- Rooftop solar power
- Oil Pollution Control
- Solid waste disposal
- Cutting of trees and Green Belt.

5.5.1 Water Supply

251. Water required for operation of depot shall be sourced from municipal supply. This shall be supplemented by rainwater harvesting. Treated sewage will be used for horticulture and non-drinking purposes in operational facilities and staff quarters if any. Train washing requires 22 KLD by year 2055, generating 19 KLD sewage. Water demand will be 70 KLD for domestic purpose including staff quarters at Poonamallee depot resulting sewage will be 63 KLD.

252. To conserve and augment the storage of groundwater, it has been proposed to construct rainwater harvesting structures in the proposed depots to receive runoff from sloping roof of the depot as well as recharge of ground water in uncovered land area. On Depot potential for rainwater harvesting is 0.77 lakh cum per year from roof of structures in the depots. In addition, estimated quantity of 1.57 lakh cum per year will be available for ground water recharge

5.5.2 Sewage Treatment and Effluent Treatment

253. Sewage will be generated from depot which could be treated up to the level so that it could be used for horticulture and non-drinking purposes in the Depot. For Poonamallee Bypass depot Sewage Treatment Plant (STP) and Effluent Treatment Plant (ETP) are proposed. The wastewater from depot will have oil, heavy metals grease and detergent as main pollutants. This has to be treated as per requirement of Tamil Nadu State Pollution Control Board.

5.5.3 Solar Plant

254. Rooftop solar panels on covered part of depots are proposed. As per Ministry of renewable Energy (MNRE) template, 5% of rooftop area of depot can generate 3.51 lakh kWh per year in Poonamallee Bypass depot.

5.5.4. Oil Pollution Control

255. Oil spillage during change of lubricants, cleaning and repair processes, in the maintenance Depot cum workshop for maintenance of rolling stock, is very common. Oil spilled in Depot should be trapped in oil and grease trap and disposed to authorised collectors so as to avoid any underground/ surface water contamination. Oil that is mixed in water shall be removed in the ETP.

5.5.5 Solid Waste Disposal

256. The solid waste generated from the Depot will be taken by the cleaning contractor weekly and disposed to the municipal waste disposal sites. It is estimated that municipal solid waste of about 0.18 ton per day will be generated from Poonamallee Bypass depot.

5.5.6 Cutting of Trees

257. About 396 trees in Poonamallee Bypass depot are likely to be cut. 4,752 trees will be replanted to offset the tree loss of depot.

5.5.7 Noise and Vibrations

258. The main source of noise from depot is the operation of workshop. The roughness of the contact surfaces of rail and wheels and train speed are the factors which influence the magnitude of rail - wheel noise. The vibration of concrete structures also radiates noise. Due to less activity, no impact on the ambient noise is anticipated.

5.6 Chance Finds

259. Corridor 4 alignment is in urban areas and there may be possibilities that some artifacts could be found during piling and excavation work.

260. Mitigation Measures: before start of civil work the contractor and CMRL will coordinate with State Archeological department to reconfirm that there is presence of buried artifacts along the metro line alignment. No piling or excavation will be allowed unless cleared by the Archeological Department.

261. All workers will undergo a briefing with the Archaeology Department to ensure safeguarding of heritage resource and cultural/religious practices.

262. A proof of compliance to this requirement to include the name of participants and date and location of briefing will form part of the monthly report to CMRL.

263. The contractor will comply with the FIDIC Sec. 4.24 on Fossils. Recording (including chain of custody) will be made by the contractor to be validated by the GC, and expert verification will be made by the Archaeology Department. Temporary work stoppage in the immediate area of the chance find for up to 72 hours to allow for the on-site representative of Archaeology Department to visit the site to make an assessment and provide instructions. Work in the areas adjacent to the chance find will continue as provided in the detailed design.

5.7 Expected Benefits from Corridor 4

264. Metro rail systems have an advantage over other modes of transport because they provide higher carrying capacity, faster, smoother, and safer travel, occupy less space, and are non-polluting and energy-efficient. To summarize the benefits of a metro rail system:

- **Reduced Air Pollution:** Reduction in air pollution level is the single most important indications due to metro rail alignment.
- **Increased Employment Opportunities** During the period of construction manpower will be needed for various project activities. In post-construction phase, about 913 people will be employed for operation and maintenance of the system. In addition, more people would be indirectly employed in allied activities.
- **Improved Economy:** The project will facilitate movement of people from different parts of Chennai. Corridor 4 will yield benefits in terms of growth in economic activity due to better accessibility, savings in fuel consumption, corresponding reduction in cost of road construction and maintenance, reduction in vehicle operating costs, savings in travel time, improvement in quality of life and reduction in loss of productivity due to health disorders resulting from pollution.
- **Mobility Safety and Reduced Accidents:** The metro network increases the mobility of people at faster rate. The proposed corridor will provide more people connectivity to other parts of the city. Metro journey is safe and result in reduced accidents on roads.
- **Reduced Fuel Consumption:** Based on number of daily vehicle kilometre reduction, daily reduction in fuel (diesel and petrol) consumption has been estimated. The reduction has been estimated based on retiral - without addition - of pre-BS VI vehicles from year 2020 onwards; in accordance with the report commissioned by Niti Aayog, 100% of 3 wheelers and buses and 40% of private 2 wheelers and cars have been assumed to be electric from year 2030 onwards. The benefit is an interplay between shift from road modes to Metro and shift from more polluting pre-BS VI road vehicles to less polluting BS VI road vehicles. The estimated daily vehicle-kilometre that will be reduced due to operation of Corridor 4 is given in Table 5.15. Reduction in fuel consumption is reported in Table 5.16. The reduction of air pollution is presented in Table 5.17. Net reduction in CO₂ has been estimated as result of trade-off between ambient reduction due to operation of metro rail and increase due to grid power used to operate the Metro.

Table 5-15: Reduction in Daily Vehicle kilometers

Mode	Daily vehicle km Reduced due to Corridor 4		
	2025	2035	2045
Bus	1,065,268	1,429,592	1,614,089
2 wheeler	225,656	528,539	804,727
Car	135,548	379,296	476,847
3 Wheeler	60,562	137,509	201,331

Source: Detailed Project Report for Corridor 4 Chennai Metro Phase 2, Oct. 2018

Table 5-16: Reduction in Fuel Consumption (million litre per year)

Mode/Year	2025	2035	2045
Diesel	96.30	0.20	0.30
Petrol	2.90	3.50	4.70

Table 5-17: Pollution Reduction (ton/year)

Pollutant	2025	2035	2045
CO	2,581	195	276
PM	57	1	1
HC+NO _x	2,475	32	45

CO ₂ (net)	180,839	71,809	53,834
Treatment cost (Rs million per year)	602	59	59

6. ANALYSIS OF ALTERNATIVES

6.1 Introduction

265. This section presents the symmetrically compared feasible alternatives to Corridor 4. Alternatives such as other sources of transport (road, mono-rail, suburban rail), proposed design etc. have been considered and analyzed for its likely impacts on various environmental parameters. Additionally, an evaluation of potential environmental impacts in terms of 'with' and 'without' project situation has been considered for the justification of the project. This section also presents a discussion on how environmental parameters were assigned due importance and considered in the analysis of alternatives.

6.2 Different Modes of Transport and Need to Increase Public Transport Share

266. The urban transport model was developed as part of Feasibility Study for travel demand assessment and to arrive at influential mass rapid transit corridors. The need for quantum increase in transport capacity of the current network by means of rapid transit along proposed corridors is indicated by inadequacy of road capacity. Major roads along the proposed project alignment are forecast to function beyond respective design service volume in absence of the Corridor. The study estimated Peak Hour Peak Direction Traffic (PHPDT) of 17,200 for Corridor 4 with a daily ridership of 4.1 lakh passengers in horizon year 2035.

267. The Comprehensive Mobility Plan (CMP) for CMA, February 2018 forecasts that these major roads e.g., Venkatanarayana Road, Arcot Road, Kalamman Koil Street, Mt. Poonamallee Road will carry traffic load which is beyond their capacity. The CMP identified 8 mass transport corridors which are forecast to carry peak hour peak direction traffic ranging from 11000 to 35000 which is more than capacity of bus transport in form of discrete buses. One of these 8 corridors is from Lighthouse to Poonamallee via Porur.

268. The development of the two scenario starts with estimating the traffic and the modal share in these scenarios for the system. As per travel demand forecast on revised network in DPR 2018, Corridor 4 will cater daily boarding of 5.5 Lakh in 2025 and 11.4 Lakh in 2055; maximum sectional PHPDT on Corridor 4 will correspondingly increase from 11,707 to 29,940.

6.3 Analysis With and Without Project Scenario

269. In case Corridor 4 is not constructed, the city will be deprived of the following benefits:

- Economic prosperity
- Mobility and access to economic opportunities
- Comfort and Safety, particularly for women and differently abled people
- Traffic Congestion Reduction, Reduction in Number of Buses
- Reduced Fuel Consumption, Reduced Air Pollution
- Carbon Dioxide and Green House Gases (GHG) Reduction
- Optimality in transportations

270. Benefit in terms of reduction in air pollution due to operation of Metro is estimated in Chapter 5. Since the positive impacts are more than a few negative impacts, consideration of 'no development alternative' is a non-starter and has thus not merited any further consideration.

6.4 Comparison of Alternative High Capacity Modes

271. Table 6.1 presents comparison of unit life cycle costs of Metro, Light Rail Transit (LRT) and Bus Rapid Transit (BRT). The costs pertain to traffic demand forecast on MDBs project corridors and are based on data for such systems operating or evaluated for Indian conditions.

Table 6-1: Cost Comparison of urban mass transit systems

S.No	MDB project Corridor	Forecast traffic demand in year 2055 PHPDT (length of section)	Life Cycle Cost (Rs lakh per seat) rounded off		
			Metro elevated	Light Rail elevated	BRT at grade
1	Lighthouse to	Lighthouse to Nandanam Underground 6.18km	>80 to 36 *	>80 to 33 ** 2c	>36 to 25 ** 2b
2	Poonamallee bypass (25.4km)	Nandanam to Meenakshi College Underground 3.08 km, Meenakshi College to Porur Junction elevated 7.97km	>29 to 23 ** 4c	33 to 20 ** 4c	25 to <22 ** 2b
3		Porur Junction to Poonamallee Bypass elevated 8.2km	24 to 18 ** 6c	19 to 15 * 6c	21 to 19 *
Assumed Capacity per coach/bus			270	242	80

* Section 9.3, Life Cycle Cost Analysis of Five Urban Transport Systems, IUT (India), 2012.

** Section 9.4, Life Cycle Cost Analysis of Five Urban Transport Systems, IUT (India), 2012, 4c: 4 car set. Average speed: Metro 35kmph, LRT or BRT 25kmph; average station/stop spacing: Metro 1km, LRT or BRT 0.75km, headway: Metro or LRT 2.5minutes, BRT 0.60 minutes

272. The above tabular statement shows that BRT has significantly lower unit life cycle cost from Lighthouse to Nandanam. LRT shows no significant advantage to Metro on other sections.

273. Road right of way is not adequate to operate BRT. Therefore, it is considered that continuity of Metro on the project corridors is preferable. In terms of reduced air pollution, benefit of Metro on the project corridors is estimated in Chapter 5 of this report; BRT adds to ambient pollution in comparison to Metro.

274. Screening distance recommended for vibration induced by rubber tyred vehicles is 16m against 67m and 50m respectively for rapid rail and light rail (Transit Noise and Vibration Impact Assessment, US FTA, May 2006): this indicates that exposure zone of BRT buses will be smaller than Metro.

275. Screening distance recommended for noise generated by bus on BRT is 70m against 233m and 116m respectively for rapid rail and light rail (Transit Noise and Vibration Impact Assessment, US FTA, May 2006): this indicates that noise exposure zone due to BRT buses will be smaller than Metro.

6.5 Selection of Alignment, Stations and Depot Locations

276. While fixing the alternatives on proposed corridor, following requirements/ constraints have been kept in view:

- To remain on corridor of the existing road or Government premises/land to the extent feasible.
- To utilize the existing road Right of Way to the maximum extent in order to minimise the land acquisition and also length of diversions.
- To avoid dismantling of existing structures/buildings etc. to the extent feasible.
- To avoid private built up areas, villages, habitation and religious structures etc. to the extent feasible.
- To provide adequate clearance from existing Railway/ Highway structures.
- To satisfy the requirements of sound economic engineering practices

- To rationalise the location of proposed stations and underground ramps

7. PUBLIC CONSULTATIONS AND INFORMATION DISCLOSURE

7.1 Consultations

277. MDBs' policies require projects to carry out meaningful public consultation on an ongoing basis. Public consultation will: (i) begin early and carry on throughout the project cycle; (ii) provide timely disclosure of relevant information, understandable and accessible to people; (iii) ensure a free and un-intimidated atmosphere without coercion; (iv) ensure gender inclusiveness tailored to the needs of disadvantaged and vulnerable groups; and (v) enable the incorporation of all relevant views of affected people, and stakeholders into project decision making, mitigation measures, the sharing of development benefits and opportunities, and implementation issues.

278. Public consultation and participation are a continuous two way process, involving, promoting of public understanding of the processes and mechanisms through which developmental problems and needs are investigated and solved. The public consultation, as an integral part of environmental and social assessment process throughout the project preparation stage not only minimizes the risks and manages the expectation of the project but also abridges the gap between the community and the project formulators, which leads to timely completion of the project and making the project people friendly.

279. Public consultation/information is an integral part of the Chennai metro project cycle. Public consultations with the people of different sections of the society along the project alignment, shopkeepers, and influential persons of the project area were made. Potential vulnerable people like, squatters, encroachers, schedule caste, and other backward section of society were consulted to make them aware and identify adverse impacts of the project.

280. The consultation process started early in 2017. CMRL held extensive consultation with the local community to share information of potential impacts and mitigation measures etc.

7.2 Identification of Stakeholders

281. Key stakeholders at central, state, district and local level will be consulted as part of the consultation process. This will be documented in the updated EIA prior to the contractors' mobilization.

- Ministry of Environment, Forests and Climate Change,
- Central Pollution Control Board,
- Tamil Nadu State Pollution Control Board,
- State Environmental Impact Assessment Authority
- Tamil Nadu Coastal Zone Management Authority
- State Traffic Police Department
- Municipal Corporation
- State Archaeology Department
- Central Ground Water Authority
- District Forest Office
- Indian Meteorological Department
- Non-government organizations
- Women groups
- Shopkeepers associations

7.3 Public Consultations

282. In order to enhance public understanding about the project and address the concerns of the community pertaining to mitigation of adverse impacts due to the Corridor, meetings with groups of persons comprising likely PAPs and other stakeholders in the community were conducted during the field survey that was carried out during preparation of the detailed project report. These consultations are summarized in Table 7.1.

Table 7-1: Summary of Public Consultations Part 1

Location	Date	Number of participants	Suggestion/Opinion
Thirumayilai	29.05.2017	8	Underground track may not be suitable for Mylapore as it is a very old area with heritage buildings- temples, church etc. Many buildings/ residents are century old; therefore there is a great risk of collapse
			If construction activities go long more than expected, then it incurred loss to commercial/ shops.
			Metro will reduce the traffic jam. The long distance travel will be easy and metro will increase the connectivity
Poonamalle Depot	20.11.2018	8	It will become easier for them to have convenient and easy transport system
			There is a possibility to have pollution and traffic problem during construction of the metro project
			Loss of trees is another major concern according to the respondents. Tree transplanted shall be taken care of.
			The lady respondents said that the proposed metro project will be helpful for her because metro offers special a special compartment for ladies only
Vadapalani	11.11.2016	13	Being a small shop owner, our livelihoods will totally loss. There has to be adequate provision of compensation
			Metro will reduce the existing traffic load and reduce the level of pollution
			Metro will reduce the traffic and reduced in road accidents
Stella Maries College	30.05.2017	10	Construction activity will result traffic jam. As this place is fully commercial, metro construction may disrupt the traffic flow
			In Chennai city, the greenery is as it is low and further infrastructure development will further reduce the green cover and need to take care of it.
			Metro will reduce pollution and speedy up transportation
			The traffic is huge due to nearby colleges and commercial area nearby. Metro train will be helpful to reduce the traffic load

Location	Date	Number of participants	Suggestion/Opinion
Poonamalle Bus Terminus	03.07.2018	12	Construction activity will result traffic jam. As this place is fully commercial, metro construction may disrupt the traffic flow
			The existing transportation charges are too high unless it is lessening metro will not be successful. Fares must be reasonable
			The metro train might reduce the green cover and it needs to be taken care of
			The respondents reported that they do not want metro rather they would like to have highways and over bridges
			Metro will reduce the traffic and road accidents.
Iyappanthanagal Bus depot	03.07.2018	12	The metro train facility will save time to reach the destinations in comparison with other means
			Proposed metro project will reduce the travel time
			It would be easy to reach to the destinations due to the proposed metro project
Total participants		63	

Source: Comprehensive DPR for Chennai Metro Phase II, December 2018

283. The second round of public consultations was conducted in 2018/2019. The summary of the consultations is placed in Table 7.2. Participation by locations is summarized in Table 7.3.

284. For instance, in Thirumayilai, it was reported that the underground track may not be suitable for Mylapore as it is a very old area with heritage buildings -temples, church etc. Many buildings /residents are century old. Therefore, there is a high risk of collapse of old structures. Similarly many of the places participants raised the concern that construction activity may affect their livelihood as well as structures/buildings. The issue of compensation was raised in Kodambakkam. As reported by participants, metro trains will surely argument infrastructure and other facilities, but participants strongly suggested that the affected families /people should get adequate compensation in order to reinstate the life of people. Participants from Adyar Gate highlighted their concern regarding air pollution and suggested that the green cover in the city of Chennai is less and metro project should not affect the existing level of greenery. Similarly the participants of Vadapalani, Nandanam and Porur raised the concern regarding affairs of travelling in metro rail. Participants suggested that metro fares should be moderate.

285. At many places participants highly appreciated the upcoming phase- 2 metro projects as it will increase connectivity, reduce the traffic load and reduce existing level of pollution. Women felt that the proposed project will provide (i) better access to higher levels of education, health services (especially in emergencies), and social interactions; (ii) better transport option; and (iii) increase in leisure time.

Table 7-2: Summary of Public Consultations Part 2

S.no	Issues Discussed	Important opinions and views	CMRL reply
1	Overall Project	What are the advantages & disadvantages of this project	<ul style="list-style-type: none"> Associated Environmental (positive & adverse) impacts with this project were explained in detail.

S.no	Issues Discussed	Important opinions and views	CMRL reply
			<ul style="list-style-type: none"> R&R plan and the possibility of new Employment opportunity for the aspirant PAPs was explained in detail.
2	Land	What is the basis of compensation of land?	Compensation for land is calculated on the basis of circle rate. In addition to the circle rate, 100% solatium will also be paid.
3	Land Acquisition	Why few lands were shifted even though stations were not at that particular area?	<ul style="list-style-type: none"> CMRL assured that the land is being temporarily acquired for safety reasons. They are not permanently shifted because it is an old and large settlement and only 18 affected families. Sufficient time will be given for vacating the premises. CMRL will provide rent to the affected families for the acquisition period. The amount is being worked out and will be informed shortly.
4	Compensation	What will be the compensation for acquisition of buildings?	Cost of Building is based on valuation. In addition, 100% solatium will also be paid.

Source: SIA for CMRL-II, Corridor 4, Final 2019

Table 7-3: Participation in Public Consultations by Location Part 2

SN	Date of public consultation	Location	Number of participants
1	06.12.2018	Kutchery Road	45
2	07.12.2018	Thirumayilai Metro	7
3	11.12.2018	Alwarpet	33
4	13.12.2018	Bharathidasan Road	91
5	14.12.2018	Adyar Gate Junction	49
6	18.12.2018	Nandanam	6
7		Natesan Park	30
8		Panagal Park	9
9	21.12.2018	Kodambakkam Metro	112
10	19.12.2018	Meenakshi College	4
11	02.04.2019	Power House	5
12		Vadapalani	11
13		Saligramam	12
14		Avichi School	26
15		Alwarthiru Nagar	36
16	01.04.2019	Valasaravakkam	17
17		Karambakkam	5
18		Alapakkam Junction	44
19		Porur Junction	31
20	03.04.2019	Ramachandra Hospital	-
21		Iyappanthangal Bus Depot	1
22	02.04.2019	Kattupakkam	-
23		Kumanan chavadi	-
24		Karayan chavadi	-
25		Poonamallee Bus Terminus	-
26		Poonamallee Bypass	-

SN	Date of public consultation	Location	Number of participants
27		Depot-Poonamallee	17
28	09.01.2019	Meenakshi College MS	2
29		Thirumylai MS	-
30		Alwarpet	-
31		Adyar Gate Junction	-
Total Participants			593

Source: SIA for CMRL-II, Corridor 4, Final 2019

286. Public consultations during construction and operation will form part of semi-annual monitoring reports sent by CMRL to MDBs. These consultations will focus on the impact mitigation measures being implemented and their efficacy.

7.4 Information Disclosure

287. Information disclosure will follow the procedure and disclosure requirements of MDBs' policies for category A projects. As per ADB's SPS 2009, the EIA shall be disclosed 120 days prior to ADB's Board Approval.

288. All environmental documents are subject to public disclosure, and therefore, will be made available to the public. This EIA and the Executive Summary (in both English and Tamil) will be disclosed on CMRL and MDBs' websites. The hard copies of EIA will be made available at CMRL office as well as at other locations accessible to stakeholders. CMRL will ensure that meaningful public consultations, particularly with project affected persons' are undertaken throughout the design, construction and operation stages.

8. GRIEVANCE REDRESS MECHANISM

289. Grievance Redress Mechanism (GRM) is an integral and important mechanism for addressing/resolving the concern and grievances in a transparent and swift manner. Grievances related to the implementation of the project, particularly regarding the environmental management plan, rehabilitation and resettlement, compensation etc. will be acknowledged, evaluated, and responded to the complainant with corrective action proposed using understandable and transparent processes that are gender responsive, culturally appropriate, and readily accessible to all segments of the affected people. Records of grievances received, corrective actions taken, and their outcomes will be properly maintained and form part of the bi-annually environmental monitoring report to MDBs.

290. Many minor concerns of peoples are addressed during public consultation process initiated at the beginning of the project. However the most common reason for delay in implementation of projects in urban areas is grievances of people losing their land and residential and commercial structures. Resolving such cases in the Court of Law will be a very time consuming process. Considering this and based on CMRL's past experiences of dealing with PAP grievances, a GRM has already been put in place in order to address the grievances of project affected persons. Such a redress mechanism available at the project level itself will mean that the complainants do not necessarily have to directly approach a Court of Law although availability of Grievance Redress Committee (GRC) mechanism will not bar them from doing so.

291. GRM will be in two layers: a) executing engineer from Project Implementation Unit (PIU) and b) GRC. The first level of interaction of GRM with the stakeholders will be the Executing Engineers from PIU to resolve ground level grievances including construction nuisances with support from contractor GRM focal. Issues should be resolved within 14 days. Those that cannot be resolved by PIU will be escalated to be examined by the GRC. Alternately complainants aggrieved by inadequacy of actions taken by the executing engineer can escalate to the GRC.

292. The Environmental Health and Safety Expert on the CMRL PIU who is an environmental engineer will coordinate the GRC which will report to MD, CMRL and Director Projects, CMRL. The other members of the GRC will be,

- CMRL Project Manager of the package/section
- EMP implementation teams from CMRL and GC
- EMP Manager from construction contractor
- Assisting NGO
- PAPs and representatives
- With a view to Affirmative Action to enhance women inclusivity, one-woman representative of local community from each 5km section of the alignment will be members of the Environmental and Social Grievance Redressal Committee. The representative(s) from the location(s) to which the grievance(s) pertain(s) shall be invited to deliberations of the Committee.

293. Records of the following stages will be maintained on website of CMRL throughout the life of the project:

- Complaints received
- Acknowledgement of receipt of complaint by executing engineer PIU
- Actions taken by executing engineer and their efficacy
- Escalation by executing engineer or by aggrieved parties
- Records of further action and closure of complaints.

294. Complaints and escalation by aggrieved parties can be done by paper mode as well as through email. The GRC will deliberate upon time limits for each of the above stages; the time limits will be placed on website of CMRL.

295. The flow chart of GRM is presented in Figure 8.1.

Figure 8-1: Grievance Redress Mechanism

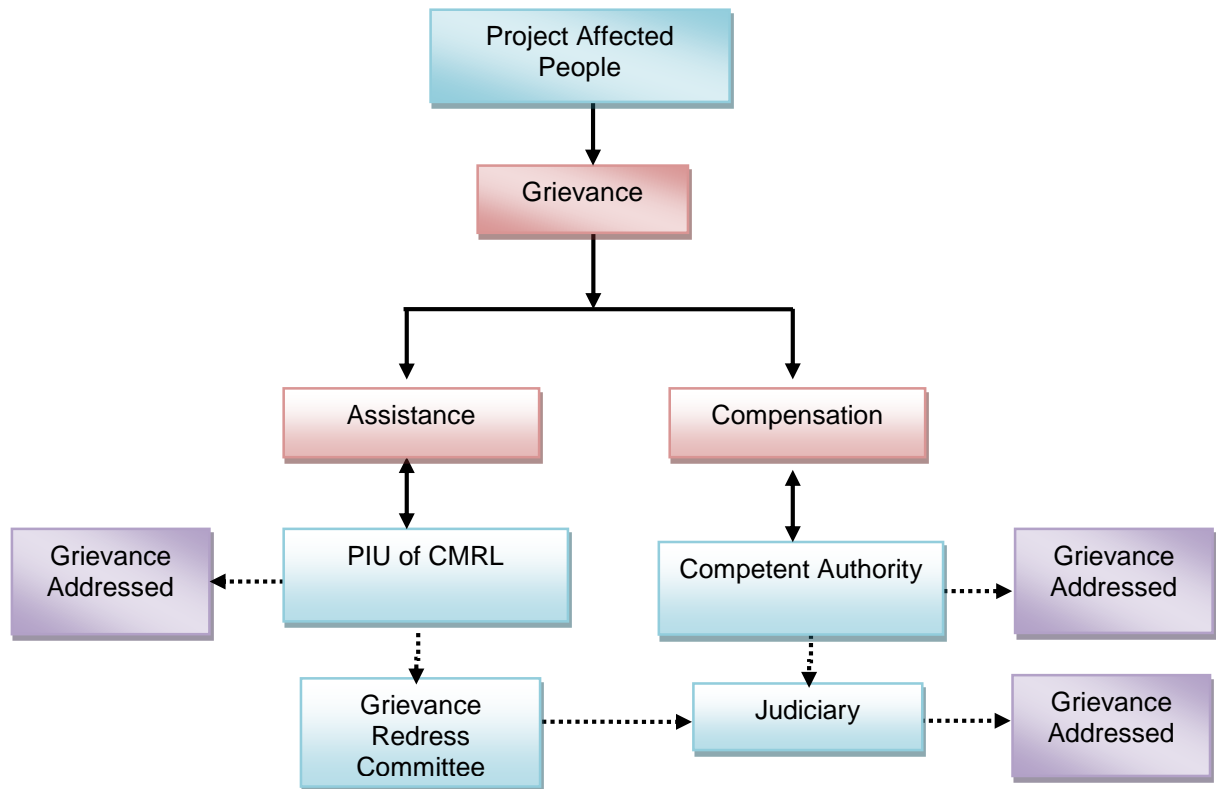

296. The following process is followed for consideration of various cases by GRC:

- GRC function independently
- All grievances are received in written form by GRCs and a separate record of the same, including contact details, is maintained
- A separate file / processing document is created for each case, based on its category (project, location etc.) and all observations and documents related to the case are maintained in such file
- Cases related to environment pollution, noise, eligibility, entitlements, disputes etc. are promptly handled after consultation with relevant authorities
- GRCs can seek necessary record / information (such as survey details, past written communication etc.)
- Written notices are sent to the aggrieved persons and respondents to appear for hearing along with documents, and further dates are provided in case of genuine inconvenience to the party about the appointed date
- Multiple hearings are conducted as per the requirements of cases and aggrieved persons (including their representatives) and respondents are heard and are provided opportunities to submit further documents / proofs
- Site visit documents submitted by the parties are verified from appropriate sources, as may be considered necessary

- In normal circumstances (excluding those requiring information from external agencies) the entire process is carried out in a time bound manner (On an average, it takes about 1-2 months for disposal of each case in GRC)
- After due consideration of the cases, written and reasoned orders are passed under the signature of Head of concerned GRC
- Any fatality accident should be reported to GRC and MDBs immediately

297. In addition to the above GRM for addressing complaints from the local community, a separate GRM will be constituted by contractor for addressing the issues of the workers, forming part of the bidding document for CMRL to review and clear. The clauses in the tender include the followings,

- Enquiries, complaints and requests for information can be expected from a wide range of individuals and organisations both private and government. The majority of complaints is likely to be received by CMRL, although the site offices are also likely to be contacted.
- The objective of complaint process is to ensure that public and agency complaints are addressed and resolved consistently and expeditiously.
- The Contractor's Project Manager will be notified immediately on receipt of complaint that may relate to environmental impacts. The Project Manager will immediately inform the Employer's Representative.
- Field investigation should determine whether the complaint has merit, and if so action should be taken to address the impact.
- The outcome of the investigation and the action taken shall be documented on a complaint Performa prepared by the Contractor and submitted for notice by the Employer's Representative in advance of the works.
- Where possible, a formal response to each complaint received shall be prepared by the Contractor within seven days in order to notify the concerned person(s) that action has been taken.
- Grievance log should be prepared and documented in the monitoring report with the resolution details.
- GRM for workers shall be established as early as possible to function no later than construction commencement.
- The GRM information and focal should be disseminated to public.

9. ENVIRONMENTAL MANAGEMENT PLAN

9.1 Introduction

298. The Environmental Management Plan (EMP) consists of a set of mitigation, monitoring and institutional measures to be taken for Corridor 4 to avoid, minimize and mitigate adverse environmental and social impacts and enhance positive impacts. The plan also includes the actions needed for the implementation of these measures. The major components of the EMP are:

- Mitigation of potentially adverse impacts;
- Environmental monitoring;
- Emergency response procedures;
- Institutional arrangements and reporting mechanism;
- Implementation Schedule;
- Training and capacity building; and
- Cost estimates.

9.2 Objectives of Environmental Management Plan

299. The main objectives of this EMP are:

- To ensure compliance with MDBs' applicable policies, and regulatory requirements of GoTN and Gol;
- To formulate avoidance, mitigation measures for anticipated adverse environmental impacts during construction and operation, and ensure that socially acceptable, environmentally sound, sustainable and good practices are adopted; and
- To stipulate monitoring and institutional requirements for ensuring safeguard compliance.

9.3 Institutional Arrangement

9.3.1 Executing Agency

300. GoTN created a SPV for implementing the Chennai Metro Rail Project. This SPV named as "Chennai Metro Rail Limited" was incorporated on December 03, 2007 under the Companies Act. It has now been converted into a Joint Venture of Gol and GoTN with equal equity holding.

301. GoTN and Gol will be the Executing Agency (EA) of the proposed Corridor 4 (Phase-II).

9.3.2 Implementing Agency

302. CMRL will be the Implementing Agency responsible for implementation of the metro rail project. Managing Director, CMRL will be in charge of the overall project activities. CMRL will be accountable to the GoTN (i.e. the EA).

303. PIU, CMRL headed by the Project Director (PD) is responsible for the overall execution of the project and implementation of the EMP. The PIU will be assisted by General Consultant (GC). The safeguard role of GC is to assist CMRL in review of documentation and monitoring of implementation of EMP and monitoring plan during construction and operation by means of scheduled inspections, meetings and reports submitted to CMRL. The terms of reference are attached as **Annexure 6**.

9.3.3 Implementation of EMP

304. CMRL: EMP will be committed by CMRL as part of its agreement with MDBs. The responsibility to implement the EMP including Grievance Redressal rests with CMRL. Environment clearances related to locations and design of the project will be secured before start of construction. Permissions/certifications required during operation of the project. Environment monitoring during operation.

305. Contractors: Permits required during construction and those directly related to construction. The EMP will be implemented by the contractors of different packages based on the contract agreement. The contractor environmental team will be headed by senior Manager assisted by qualified and trained safety professionals and environment engineers along with onsite junior field personnel. This team will be assisted by:

- electrical and mechanical engineers qualified in safety evaluation;
- environment engineer;
- traffic engineer; and
- professionals in occupational health and labour welfare.

306. The Employer Requirements for ESHS have been prepared for Corridor 4; they will be issued to the Contractor as part of the contract documentation for construction.

307. CMRL and GC: Supervision and review of implementation will be the responsibility of GC. With assistance from GC, CMRL will also be responsible for reviewing and approving any specific documents/plans that have to be provided by contractors (traffic management plan, waste management plan, muck disposal plan etc.). Implementation of EMP will be continuously monitored by the ESHS team of GC and CMRL. The CMRL-GC team will be common for all sections of the project with a view to facilitate unified approach and knowledge enhancement.

308. The CMRL's ESHS team will be headed by senior Manager assisted by qualified and trained mid-level safety professionals, environment engineers, traffic engineer, labour welfare officer. The Manager ESHS for the project in CMRL will report directly to Director (Works) and Managing Director, CMRL.

309. GC will contribute,

- Specialists from fields of safety, environment, traffic engineering, occupational and community health, ecology, noise and vibration
- Onsite junior field personnel, at least one site each.
- The visits and review meetings will comprise:
 - Weekly site visits independently by CMRL and jointly with contractor;
 - Weekly review meetings by CMRL and contractor;
 - Quarterly monitoring reports to CMRL;
 - Bi-annual monitoring reports to MDBs.
- Orientation and training of CMRL team in implementation of EMP and environmental monitoring will be undertaken at the beginning of the project.

310. MDBs: Disclosure of all latest safeguard documents on their websites. Implementation of the EMP will be monitored half yearly by MDBs through their specialists.

311. External Monitor: An external monitor will be engaged by CMRL in consultation with MDBs to evaluate the environmental performance of abovementioned parties with the listed responsibilities as below. The agency will report to CMRL who in turn report it to MDBs. The terms of reference are attached as **Annexure 7**.

- To conduct third party monitoring of environmental compliance under the project;
- To ensure that the Project will be implemented in conformity with the policies of Gol, GoTN, as well as MDBs’ policies;
- To Identify any safeguard related implementation issues and necessary corrective actions and reflect these in a time-bound corrective action plan for CMRL to implement;
- Capturing social, environmental and economic benefits and particular potential benefits to the poor and vulnerable groups in the corridor;
- Involving users and stakeholders in the monitoring process; and
- Strengthening the capacity of the CMRL to manage and replicate third-party monitoring with rail users and stakeholders.

312. The reporting line of all relevant parties is, Contractor → PIU → CMRL and GC → MDBs. The external monitor will conduct independent monitor to inform CMRL any remediation actions to ensure the safeguard compliance.

313. An EMP Matrix is presented in Table 9.2.

9.4 Environmental Monitoring and Reporting Program

314. Environmental Monitoring Plan (EMoP) is a companion document of the EMP. EMoP contain parameters, location, sampling and analysis methods, frequency, and compared to standards or agreed actions that will indicate non-compliances and trigger necessary corrective actions. More specifically, the objectives of the EMoP are:

- Ensure that impacts do not exceed the established legal standards
- Check the implementation of mitigation measures in the manner described in the EIA report
- Monitor implementation of the EMP
- Provide an early warning of potential environmental damage
- Check whether the proposed mitigation measures have been achieved the intended results, and or/ other environmental impacts occurred

315. The monitoring plan will be used for performance monitoring of the project. A monitoring plan defining all parameters to be monitored, with tentative location, project stages for measurements, implementation and institutional responsibility for different environmental components is prepared for all stages of project and presented in Table 9.3.

316. Monitoring and Reporting Frequency for implementation of the EMP is shown in Table 9.1.

Table 9-1: Monitoring and Reporting for EMP and EMoP

Particulars	Frequency of reporting	Reporting by / Reporting to	Review by/ Monitoring by
Starting from deployment of construction contractor from site selection period	Monthly till completion of construction	a) Contractor / GC b) GC / CMRL SH&E team, CMRL SH&E team/MD, CMRL c) CMRL SH&E team/MD, CMRL	CMRL
a) Implementation of EMP and EMoP			
b) Monitoring of implementation of EMP and EMoP			
c) Grievance Redressal			

Particulars	Frequency of reporting	Reporting by / Reporting to	Review by/ Monitoring by
a) Implementation of EMP, EMoP and Grievance Redressal and their internal (CMRL) monitoring b) Outcome of continuing public consultations	Bi-annually till completion of construction	All by CMRL / MDBs	<ul style="list-style-type: none"> • MDBs • TNPCB
Evaluate implementation and internal monitoring of EMP, EMoP, Grievance Redressal and their efficacy	Semiannually during construction	External Expert / CMRL	MDBs
a) Implementation of EMP by CMRL and EMoP by external agency b) Monitoring of EMoP c) Grievance Redressal	Semiannually during first 2 years of operation & maintenance	a) and b) <ul style="list-style-type: none"> • EMoP Agency / GC • GC / CMRL SH&E team • CMRL SH&E team/MD, CMRL c) CMRL SH&E team/MD, CMRL	CMRL
a) Implementation of EMP, EMoP and Grievance Redressal and Internal (CMRL) monitoring b) Outcome of continuing public consultations	Semiannually during first 2 years of operation & maintenance	CMRL / MDBs	<ul style="list-style-type: none"> • MDBs • TNPCB
Evaluate implementation and EMP, EMoP, Grievance Redressal and their efficacy	Annually during first 2 years of operation & maintenance	External Expert / CMRL	MDBs

Table 9-2: Environmental Management Plan Matrix

Note: This EMP Matrix will form part of the contract document together with CMRL's SHE Manual for all contractors. This EMP has been aligned with the SHE Manual wherever possible, and in places, cross referencing has been resorted to.

Sl. No.	Activity	Aspect / Parameter affected	Impact	Mitigation measures	Responsibility	
					Implementation	Supervision
Planning and Design Phase						
1.	Land Acquisition	Social	As per DPR October 2018, permanent acquisition of 5.7 ha private land. The final size of land to acquired will be updated based on the optimization of project design.	<ol style="list-style-type: none"> 1. Compensation and Resettlement benefits as well as livelihood restoration measures are under approval, governed by the following general principles, which are based on The Right to Fair Compensation and Transparency in Land Acquisition, Rehabilitation and Resettlement Act, 2013. 2. Land Acquisition is being carried out as per the provision of GoTN and GoI policies. The affected people will be compensated and assisted as per the provisions of Resettlement Action Plan. 	CMRL	GoTN
2.	Change in Land use	Land	Land use will be slightly changed	<ol style="list-style-type: none"> 1. CMRL developed the Comprehensive Mobility Plan for CMA in 2015 to identify the present and future mobility patterns of Chennai Metropolitan Area, including development of Corridor 4. 2. Proper clearance/permission/consents will be sought from competent authority before construction. 	CMRL	GoTN
3.	Contractor Management	EHS	EHS accidents Reputational Risk	<ol style="list-style-type: none"> 1. Integration of EHS contractor management into broader project management, procurement, human resources, legal, and financial management. 2. "Prevention through design": assessment of what prime contractor does versus what subcontractors do; contractor prequalification (when, if, and for what); use of information technology tools (identification cards and tracking and reporting systems for personnel and training). 3. Prime contractor will be responsible for EHS practices of the subcontractor including human resource policy which complies with applicable labour legislations, including 	GC	CMRL

Sl. No.	Activity	Aspect / Parameter affected	Impact	Mitigation measures	Responsibility	
					Implementation	Supervision
				<p>decisions on material supplies and equipment given environmentally friendly priorities, and prepare subcontract agreements accordingly.</p> <p>4. Contractor management incorporates “adaptive management” to monitor and adapt over time; integration with sustainable procurement approach or concepts.</p> <p>5. Building culture and commitment by demonstrating the importance of EHS management to the president or director of project-implementing agency and president or director of subcontractor; including EHS aspects in routine senior management project contractor meetings and reports, reflecting both criticisms or suggestions and praise; designating responsibilities of EHS staff (for example, work stoppage); requiring strong and consistent training and participation of managers; acknowledging managers’ participation in on-site supervision and resolution of issues; and providing awards, recognition, and incentives.</p> <p>6. Training and quality control plans.</p>		
4.	Contractor Preparatory Works (Upon issuance of Notice to Proceed)	EHS	Non-compliance with contract conditions and regulatory requirements.	<p>1. The Contractor shall complete the following activities no later than 30 days upon issuance of Notice to proceed, (a) appoint contractor’s Safety, Health and Environmental Officer (SHEO); (b) SHEO will engage GC-Environment Specialist to discuss EMP, seek clarification and recommend corresponding revisions if necessary; (c) SHEO will agree with GC the monthly monitoring template and deadlines for submission; (d) SHEO will submit for GC’s approval an work plan to secure all permits and approvals needed to be secured during construction stage which include but not limited to: i) operation of crushers and hot mix plants, ii) transport and storage of hazardous materials (e.g. fuel, lubricants, explosives), iii) waste disposal sites and disposal management plan, iv) temporary storage location, iv) water use, and v) emission compliance of all vehicles. Arrangements to link with</p>	Contractor / GC	CMRL

Sl. No.	Activity	Aspect / Parameter affected	Impact	Mitigation measures	Responsibility	
					Implementation	Supervision
				government health programs on hygiene, sanitation, and prevention of communicable diseases will also be included in the action plan; (e) SHEO will submit for GC's approval of the construction camp layout and management plan before its establishment; and(f) SHEO will update EIA (in consultation with GC, in case of design changes) and also prepare site-specific EMPs.		
5.	Labour Management	Labour	Labour right	<ol style="list-style-type: none"> 1. Compliance with GoI labor legislation, ratified International Labour Organization conventions. 2. Prohibition of child labor, including prohibition of persons under 18 years old from working in hazardous conditions (which includes construction activities) and from working at night; medical examinations required to determine that persons above 18 years old are fit to work. 3. Elimination of discrimination with respect to employment and occupation, to be defined as any distinction, exclusion, or preference based on race, gender, religion, political opinion, trade union affiliation, national extraction, or social origin. 4. Human resource policy or plans that establish (a) the rights and responsibilities of project company employees and any contractor employee working in the project regarding remuneration, working conditions, benefits, disciplinary and termination procedures, occupational safety and health, promotion procedures, and training and (b) the rights, responsibilities, and requirements in contractor or subcontractor agreements related to worker rights. 5. Grievance Redress Mechanism for workers should be established as early as possible to function no later than construction commencement. 6. There will be provision for group accidental insurance for the workers. 	Contractor	CMRL / GC

Sl. No.	Activity	Aspect / Parameter affected	Impact	Mitigation measures	Responsibility	
					Implementation	Supervision
		Health and Safety	Accidents	<ol style="list-style-type: none"> 1. Prepare the Health and Safety Plan for each site and assign a safety officer to monitor the compliance. 2. Make mandatory the use of safety gears (helmets, safety belts, masks, gloves, Ear plugs/ muffs and boot) by workers depending on nature of work. 3. Necessary planning and safety approach will be made for rescue during emergency. 4. Use of dust controls (exhaust ventilation) for dust control 5. Workers will be provided with first aid and health facilities at the site. 6. There should have facility to deal with medical aspects of HIV/AIDS treatment with specialized services. 7. GC to conduct Health and Safety Audit. 	Contractor	CMRL / GC
			COVID-19 response	<ol style="list-style-type: none"> 1. Taking cognizance of situation at time of mobilisation, the Contractor shall undertake a COVID-19 risk assessment of project area and prepare a COVID-19 Response and Management Plan (C-R&MP) and submit to CMRL and GC for approval. 2. The preparation of C-R&MP shall consider guidance of GoI, especially the Standard Operating Procedures and Guidelines for Construction Sites for COVID-19 Outbreak, other guidelines of WHO, International Labour Organisation, International Financial Corporation and World Bank's interim guidance note etc. The key points on COVID-19 Response and Management measures is at Annexure 8. 3. The contractor shall submit a weekly monitoring and progress report to CMRL and GC. 	Contractor	CMRL / GC
6.	Obtaining Clearance, Permission and Consents	Regulatory Compliance	Delay of obtaining CRZ clearance, Tree felling permission, Consents to establish labour camps, pre-casting and material yards, depots, establish and	<ol style="list-style-type: none"> 1. Consultation and coordination with relevant authorities to prepare the documents to obtain clearance, permission and consents. 2. Conditions set in CRZ clearance, other permission and consents to be incorporated into the site-specific EMPs, 	CMRL / Contractor	GoTN / TNCRZMA / TNPCB

Sl. No.	Activity	Aspect / Parameter affected	Impact	Mitigation measures	Responsibility	
					Implementation	Supervision
			operate hot mix plant, crushers, batching plant, DG sets etc. muck/waste disposal.	with dedicated officers to maintain the regulatory compliance tracker.		
7.	Site Clearance and Demolition	Tree felling	About 536 trees will be affected at alignments, stations and depot area. Additionally, in some areas, pruning will be required. Ecological Impacts on Panagal park	<ol style="list-style-type: none"> 1. CMRL and Contractor need to conduct a final tree inventory survey(number, type, height) with the final designs of alignment and station. Trees with conservation value should be transplanted. Plan to avoid cutting patrimonial trees, including adjustments in project design to minimize effect on such trees. 2. Revisit the works in public parks or green spaces and potential tree removal, especially involving patrimonial trees of special significance, so minimize the impacts as much as possible. 3. If unavoidable, implementation of acceptable plans for transplanting (to the extent technically and economically viable) or replacing such trees and for their short-term maintenance and care. 4. Adequate coordination with applicable government regulatory authorities. As alignment passes through built land use, green belt development along elevated section is not feasible. Compensatory plantation of 12 saplings for every tree felled will be done in sites to be identified. CMRL to allocate sufficient tree replantation budget. 5. Stakeholder communication to avoid or minimize public concerns or protests. 6. Exploration of restoration options for Panagal park enhancements, to offset negative impacts, accelerate ecosystem recovery and promote the health and longevity of the Panagal Park. Contractor and CMRL will work out an ecological restoration plan with a process of assisting the recovery of the ecosystem that will have been degraded, damaged or destroyed due to the construction of Corridor 4. Passive restoration actions may include fencing and signing sensitive areas during construction, 	CMRL / Contractor	GoTN

Sl. No.	Activity	Aspect / Parameter affected	Impact	Mitigation measures	Responsibility	
					Implementation	Supervision
				<p>which will minimize construction impacts. Active restoration actions include soil decompaction, revegetation, removal formal or informal trails out of sensitive area.</p> <p>7. Definition of adequate budget and contingencies as well as financial resources to cover all related costs. This will be finalized before work on relevant section is commenced between CMRL and Contractor.</p>		
		Noise	Noise will be generated the use of hand tools such as jackhammers, sledgehammers and picks etc.	<ol style="list-style-type: none"> 1. The procedure of demolition will be conducted as per the demolition plan prepared by the Contractor in consultation with CMRL. 2. The existing structures should be demolished one after another cautiously. 	Contractor	GC / CMRL / TNPCB
		Physical Cultural Resources	Historic and Cultural Value Loss	<ol style="list-style-type: none"> 1. Contractor to conduct pre-construction structural integrity inspections if there are known or a significant likelihood of archeological and/or culturally valuable sites or finds in the project's direct area of influence. 2. Prepare a monitoring scheme prior to construction based on the above inspections, with a focus at locations where Tunnel Boring Machine will pass close to or under, to prevent the construction delay in case structural damage occurs during tunneling. 3. Compliance with applicable legislation (permits and procedures) and good international practice. 4. Adaptive management in site-specific EMP during final design, including site locations (stations, emergency exits, ventilation shafts, and construction staging areas). 5. Chance finds procedure to be prepared by Contractor and reviewed by GC/CMRL before submitting to all lenders. 	Contractor	GC / CMRL / GoTN
		Olive Ridley Turtle	Potential Habitat Loss	<ol style="list-style-type: none"> 1. CMRL engaging an ecologist to conduct a turtle nesting ground survey prior to mobilization. 2. Consultation with TNCRZMA to prepare the turtle conservation and monitoring plan during construction. 	Contractor / GC/ CMRL	TNCRZMA

Sl. No.	Activity	Aspect / Parameter affected	Impact	Mitigation measures	Responsibility	
					Implementation	Supervision
				<p>3. GoI legislation, IFC/WB guidelines and international best practices should be integratedly followed.</p> <p>4. Assessment of actual and potential disturbance effects of project activities and develop the Biodiversity Management Plan (BMP) to ensure no net loss of any target species including Olive Ridley Turtle. The BMP will outline the actions required by the contractor to conserve or enhance biodiversity during site works particularly during piling and construction work. The BMP will be reviewed by lenders prior to contractor's mobilization.</p>		
8.	Severance of utilities	Social EHS	The proposed alignments will cross drains and utility services such as sewer, storm water drains, water and wastewater pipes, roadside lights, telephone cables, electricity power lines, electric poles, natural gas lines and traffic signals etc.	<p>1. Assets and utilities will be maintained without affecting and damages by shifting temporary/ permanently where it is necessary.</p> <p>2. Based on utility maps and network information, CMRL and Contractor in collaboration with utility owners oversees an investigation of existing utility supply infrastructure using trial pits or mix of 3D imaging and trial pits where pits pose safety hazards in built areas. CMRL and Contractor to conduct on-site inspections and a topographic survey. Even when utilities are far enough below the surface, to avoid damage from construction, they may need to be diverted so that their maintenance will not affect the safe and efficient operations of the train system once construction is completed. Utility owners will be involved in providing any new utilities needed for the rail system and in designing the necessary diversions and protection measures to minimize the risk to existing utilities from ground movement and surface settlement.</p> <p>3. For gas pipeline, Contractor will conduct the hazardous operation study to ensure the smooth and safe shifting.</p> <p>4. Utility shifting plan will be developed by CMRL and Contractor in coordination with concern authorities and shifting of utilities will be done as per agreed utility shifting plan prior to construction commenced. The plan will include required EHS management measures,</p>	CMRL Contractor /	GoTN

Sl. No.	Activity	Aspect / Parameter affected	Impact	Mitigation measures	Responsibility	
					Implementation	Supervision
				supervision and monitoring of implementation, and final report and confirmation that construction works will be properly closed (for example, all waste will be removed or re-pavement will be completed as required).		
9.	Noise and Vibration Impacts Related Design	Environmental Nuisance	Noise and vibration from construction and train operation	<ol style="list-style-type: none"> 1. The detailed noise and vibration analysis (mathematical modeling) at sensitive receptors based on final engineering designs should be carried out, based on which, a set of mitigations should be prepared and shared with all lenders for review, prior to commencement of construction. 2. Additional assessments of vibration, such as visual inspections of buildings and baseline monitoring in areas with sensitive buildings of cultural or historical significance. 3. Ballast less track structure is supported on two layers of rubber pads to reduce noise and vibrations. In addition, baffle wall as parapets will be constructed up to the rail level so as reduce sound levels. Noise at source will be controlled or reduced by incorporating suitable feature in the design of structures and layout of machines and by use of resilient mounting and dampers etc. 	Contractor	CMRL / GC
10.	Coordinate with the Traffic Department on Traffic Management Plan	Land Occupational safety Community safety	Nuisance from traffic congestion	<ol style="list-style-type: none"> 1. The Contractor shall develop detailed and robust traffic management plans consistent with the Indian Roads Congress (IRC) on Traffic Management in work zones (IRC:SP:55-2014), prior to mobilization for respective sections with site- or station-specific plans and measures to minimize the overall impact on traffic throughout the construction and operation periods. 2. At congested sections, the temporary traffic coordinators will be engaged by CMRL to facilitate the traffic management. 3. At the minimum, the traffic management plan will have the following components: construction traffic, ensuring access to properties, accommodating pedestrians, 	Contractor	GC/ CMRL/ Traffic Police

Sl. No.	Activity	Aspect / Parameter affected	Impact	Mitigation measures	Responsibility	
					Implementation	Supervision
				<p>parking, access by construction vehicles, faulty traffic lights and problem interchanges, use of public roads, parking provision during construction, use of residential streets and traffic diversion due to temporary road closures, and construction and use of temporary access roads.</p> <p>4. Strengthening impact and risk prevention measures, such as establishing construction site works to minimize the entrance and exit of vehicles at stations during peak traffic.</p> <p>5. The logistics should be considered to manage transport materials from storage areas outside of the dense urban core to worksites and to return excavated soil and other materials to disposal locations. If needed, construction traffic may be confined to certain routes (based on infrastructure capacity) or restricted to certain off -peak hours (that is, to reduce noise pollution at night or to avoid commuting and school hours during the day).</p> <p>6. Any diversions of traffic will cause considerable confusion for pedestrians and drivers as they rearrange their itineraries, hence, to minimize the effects of the diversion or reorganization, it is necessary to conduct communication campaigns and disseminate appropriate information to urban residents and taxi and bus drivers in advance of disruptions. Efforts will be given to divert traffic to roads wide enough to accommodate extra traffic. Compliance with scheduled deadlines for the detour is essential. If necessary, bus service and other public and private transport services in the area should be improved to meet residents' transportation needs.</p> <p>7. Incorporation of community safety considerations into plan design, especially at locations such as Kutchery Road where buildings are close to the construction site.</p> <p>8. CMRL and local authorities continue to play an oversight role in approving these plans during construction,</p>		

Sl. No.	Activity	Aspect / Parameter affected	Impact	Mitigation measures	Responsibility	
					Implementation	Supervision
				evaluating their cumulative impact with other infrastructure projects in the region, and ensuring their dissemination to all relevant stakeholders.		
11.	Construction method, construction material and sites selection	Environment	Pollution and nuisance	<ol style="list-style-type: none"> 1. Contractor is committed to use environmentally friendly construction methods and materials, including cement, asphalt, and base materials etc. 2. Construction material shall be sourced from legalized and approved quarries. 3. Energy saving technologies will be embedded into the Project design wherever possible. For instance, solar panels, rainwater harvesting. Bureau of Energy Efficiency (BEE) certified/ Energy efficient LED lights, automatic signaling, etc., 4. Update of plan based on final contractor-defined estimated volumes and timing for groundwater pumping with intension of minimizing the groundwater consumption. The primary objective shall be to avoid extraction of groundwater for construction. However use of groundwater which has been generated by dewatering of excavations can be used in construction activities. In those instances where extraction of groundwater becomes unavoidable, contractor shall, with consent of CMRL, resort to such extraction. In such instances contractor-defined estimated volumes and timing for groundwater pumping with intention of minimizing the groundwater consumption. 5. Procedures for minimizing waste segregation, reuse, temporary storage, recycling, donation, and disposal. 6. Selection of waste disposal service providers (transport, recycling, and disposal) based on EHS criteria (including compliance with all regulatory requirements, no documented EHS issues related to materials at operation or site facilities, and agreement to provide access for site visits to discuss EHS management). 	Contractor CMRL	/ CMRL / GC

Sl. No.	Activity	Aspect / Parameter affected	Impact	Mitigation measures	Responsibility	
					Implementation	Supervision
				<p>7. Final selection of disposal or reuse sites for extracted soils from construction and assessment and determination of truck routes from project sites to disposal or reuse site.</p> <p>8. Focus will be placed on reuse of the extracted soil for enhancement of green space, waste recycle, and storm water runoff.</p> <p>9. Construction yards with aggregate crushing and screening, pre-casting, material and fuel storage and ready-mix concrete plants will be located away from habituated or ecologically sensitive areas. Locations will be decided by CMRL and cleared by MDBs before construction commencement in consultation with Municipal Corporation/Municipalities and CMDA.</p> <p>10. The muck disposal sites shall be identified by Contractor and will be decided by CMRL before start of construction in consultation with TNPCB, Municipal Corporation/Municipalities and CMDA, to ensure a safe distance from residential areas, water bodies and ecologically sensitive locations as to avoid disrupting natural drainage. The muck shall be filled in the dumping site in layers and compacted mechanically. Suitable slopes will be maintained on the stockpile. Once the filling is complete, it will be protected by low walls, provided with a layer of good earth on the top and covered with vegetation. A muck disposal plan will be prepared by Contractor.</p>		
12.	Climate Designs	Health and Safety	Natural disasters generated health and safety accidents Maintenance Cost	1. Belt of width approx. 0.5 km of beach and developed area on alignment between Lighthouse and Kutchery Road is underground and can be subject to flooding disrupting operations. On Corridor 4, flooding gates will be installed, and adequate facilities will be made in terms of evacuation of flood water using pumps in Lighthouse, Foreshore Road and any other stations with flooding risks. Disaster management plan will pay special attention to flooding and other natural disaster to facilitate robust safety and	Contractor / GC	CMRL

Sl. No.	Activity	Aspect / Parameter affected	Impact	Mitigation measures	Responsibility	
					Implementation	Supervision
				<p>quicker evacuation, to adapt the disruption of road level access to stations due to rise in mean sea level.</p> <p>2. Other climate adaptation designs will be embedded in the final design, such as (a) improving adaptability to seasonal thermal variations in the stations through the use of large open spaces for unrestricted air movement, cross-ventilation and ensuring that enclosed areas are well ventilated; (b) designing for better adaptability to rising sea level/high tide/heavy flooding through the use of higher plinth levels and check valves for sewer lines in flood-prone areas and the use of resilient materials that can get wet and then dry out with minimal damage; and (c) rainwater harvesting through gutters and pipes to either harvesting pits or for groundwater recharge.</p> <p>3. Climate change mitigation measures will be considered, such as solar panels on station buildings and roofs to reduce the extensive use of grid-generated electricity supplied to the station for operation and maintenance.</p>		
13.	Site-specific Environmental Baseline Collection and Assessment	Environment	Benchmark of assessing project impacts	<p>1. Prior to mobilization, contractor to collect a full set of baseline data of air, water (surface and ground), noise, soil quality.</p> <p>2. Additional investigations in areas identified as having contaminated soil or groundwater to define the degree and extent of contamination and alternatives for soil and groundwater disposal. Assessment of potentially contaminated soil at site locations where soil work and excavations will be performed to examine the site situation. If there is a reasonable likelihood of contamination, then a specific management plan that includes (a) monitoring during construction consisting of visual inspections, on-site and in-situ monitoring to detect and confirm levels of contamination (and supplemented as needed by laboratory analysis), (b) on-site temporary storage and treatment, (c) final disposal (both for water and soil), and (d) worker health and safety procedures.</p>	Contractor	CMRL / GC

Sl. No.	Activity	Aspect / Parameter affected	Impact	Mitigation measures	Responsibility	
					Implementation	Supervision
				<ol style="list-style-type: none"> 3. Assessment and site-specific measures for controlling noise, dust, and illumination during construction (for example, when working 24 hours a day). 4. Confirmation of potential uses of groundwater and pumping impacts (for example, settlement or subsidence). Efforts on minimizing the groundwater consumption. 5. Contractor to prepare site-specific EMPs for CMRL to approve before mobilization. 6. Based on detailed construction work plan and associated occupational health and safety risks, strengthening the contractor health and safety management system in site-specific EMPs. 7. CMRL and GC to provide EMP orientation to contractor. 		
14.	Documents Review and Information Disclosure	Environment	Unanticipated impacts management	<ol style="list-style-type: none"> 1. With the assistance of GC, CMRL will review the above said data collections, surveys and pre-construction plans prepared by Contractor. 2. CMRL will submit to all lenders to review the documents and disclose in a timely and meaningful manner prior to construction. 	GC	CMRL
15.	Establishment of Grievance Redress Mechanism	EHS	Complaints not resolved in time	<ol style="list-style-type: none"> 1. Grievance Redress Mechanism for workers and project affected people should be established as early as possible to function no later than ground work commencement. 2. The Grievance Redress Mechanism information and focal should be disseminated to public. 	CMRL	GoTN
16.	Community Liaison	Social	Complaints	<ol style="list-style-type: none"> 1. To ensure that Grievance Redress Mechanism to function effectively for affected people on construction nuisance at ground level with grievance log well documented. 2. Contractor to develop a community communication plan per the construction plan, including important measures to reduce community risk, such as fence and related protection around work sites (including strength and visual protection), education and awareness signs and 	Contractor	GC/ CMRL/ GRC

Sl. No.	Activity	Aspect / Parameter affected	Impact	Mitigation measures	Responsibility	
					Implementation	Supervision
				information, and placement of safety risks (explosive and flammable materials, generators).		
Construction Phase						
17.	Construction Monitoring	ESH	Breach of legislation, EIA, EMP, Contracts Accidents	<ol style="list-style-type: none"> 1. Contractor to collect and monitor the Ambient environmental data of air, water (surface and ground), noise & vibration, soil quality and submit monitoring reports to GC / CMRL on monthly basis. 2. GC / CMRL to review the data compared to baseline data and urge Contractor to take immediate actions over any project generated pollution / contamination. 3. GC to submit monitoring reports on quarterly basis to CMRL. 4. If any unanticipated EHS impacts arise during construction, implementation or operation of the Project that were not considered in the EIA / EMP, Contractor and GC to promptly inform CMRL of the occurrence of such risks or impacts, with detailed description of the event and proposed corrective action plan. CMRL will report to all lenders accordingly. 5. CMRL to engage qualified and experienced third party monitor to verify information produced through the Project monitoring process, and facilitate the carrying out of any verification activities by such third party monitor. 6. CMRL to submit the semi-annual monitoring reports (GC's and third party's) using the agreed the template to all lenders. 7. CMRL to report all lenders any actual or potential breach of compliance with the measures and requirements set forth in the EMP promptly after becoming aware of the breach. 	Contractor / GC / CMRL	GoTN (clearance /permission /consents compliance) / CMRL

Sl. No.	Activity	Aspect / Parameter affected	Impact	Mitigation measures	Responsibility	
					Implementation	Supervision
		Biodiversity	Breach of legislation and BMP	<ol style="list-style-type: none"> 1. Apart from the abovementioned measures for EHS monitoring, CMRL to ensure the BMP implementation monitoring and wildlife monitoring. If any wildlife species are found in the construction site, they will be carefully transferred to safe locations within the Coastal Zone or Marsh under the guidance of the biodiversity expert and the local forestry/wildlife agency. 2. Monitor noise level to minimize the impacts, for instance, use of rotary drilling rigs which generates less noise in comparison to impact hammer. The Construction Method Statement will follow the Good International Industry Practice. 3. Monitoring habitat enhancement to deliver net benefit to any Critical Habitat species. 	Contractor / GC / CMRL	Forest Department GoTN / CMRL
18.	Community Liaison	Social	Complaints	<ol style="list-style-type: none"> 1. To ensure that ongoing timely consultations / communications with communities are provided on the progress of the project together with feedbacks on the environmental management performance of the project. 2. Grievance Redress Mechanism for affected people should function effectively with grievance log well documented. 3. Contractor will provide a minimum of two (2) weeks notification to directly affected residents, businesses and other relevant groups of the intended construction commencement date. In providing a mechanism for communication between the contractor and the community and informing the public of construction details (timing, expected impacts), CMRL will undertake consultations. 4. Adaptive management that monitors, adjusts, or adds measures to reflect actual community risks. 5. Important measures to reduce community risk, such as fence and related protection around work sites (including strength and visual protection), education and awareness 	Contractor	GC/ CMRL/ GRC

Sl. No.	Activity	Aspect / Parameter affected	Impact	Mitigation measures	Responsibility	
					Implementation	Supervision
				signs and information, and placement of safety risks (explosive and flammable materials, generators).		
19.	Truck and Driver Management	Environment Social	Community disruption Accidents Reputational risk	<ol style="list-style-type: none"> 1. Contractor's transport vehicles and other equipment shall conform to emission standards. 2. Control, inspection, and documentation of trucks prior to leaving site, including removal of soil on tires. Contractor will provide a wash pit or a wheel washing and/or vehicle cleaning facility at the exits from construction depots and batching plants. At such facility, high-pressure water jets will be directed at the wheels of vehicles to remove all spoil and dirt. 3. Definition of allowable routes, speeds, and times (day or week). 4. Driver requirements and controls, including prework medical (and blood tests) and physical inspections, ongoing monitoring (of visual and alcohol or drug use), driver training, daily total allowable work time, and allowable deviations. 5. Driver contracts with clearly specified requirements and remedies for noncompliance. 6. Use of electronic monitoring (GPS), driver training, and stops. 7. Procedure for truck maintenance, including selection of service providers considering environmental aspects, application of low-Sulphur fuel, no idling of trucks, routine maintenance (including assurance of proper engine operations related to emissions and noise), and disposal of used oil and other fluids, batteries, and tires etc. 	Contractor	CMRL / GC
20.	Leveling of Site	Land	Surface leveling will alter the soil texture and compactness, which will affect the infiltration and soil ecology. Also leveling will	<ol style="list-style-type: none"> 1. Interim drainage system will be installed prior to construction. 2. Where feasible, infiltration losses could be countered by installing Rainwater Harvesting pits away from construction site. 	Contractor	GC/ CMRL

Sl. No.	Activity	Aspect / Parameter affected	Impact	Mitigation measures	Responsibility		
					Implementation	Supervision	
			involve alteration of natural drainage				
21.	Mechanical piling	Noise	During mechanical piling operations, noise will be generated which may go up to 88-90 dB (A) at a distance of 5m	<ol style="list-style-type: none"> 1. At sensitive locations, auger piling will be carried out in place of mechanical (by driven) piling which will generate less noise than mechanical piling (around 70-75 dB(A)). Also 2m high barricade of GI sheet will be installed on all sides of piling operations. This could effectively cut down noise levels by 10-15 dB (A). Piling operations will be restricted during day time hours only. 2. Efforts should be made to keep the noise levels under control by appropriate noise attenuation and adopting employee safety measures. 3. Use of low-noise equipment and ensuring good maintenance, and trying to avoid using high-noise equipment simultaneously at the same section. 4. Wherever baseline noise already exceeds the standards, only 3 dB of noise increase is allowed. 5. Information dissemination to local residents and shop owners about the nature and duration of intended activities including the construction method, probable effects, quality control measures and precautions prior to commencement and kept updated as to changes in the management and mitigation plan. 6. Enclose especially noisy activities if above the noise limits and employ transportable noise screens between noise sources and identified noise sensitive areas for the duration of noisy construction activities. 7. Monitoring required during construction, including field observations and measurements. 	Contractor	GC/ CMRL	

Sl. No.	Activity	Aspect / Parameter affected	Impact	Mitigation measures	Responsibility	
					Implementation	Supervision
		Air	Construction will result into fugitive dust generation.	<ol style="list-style-type: none"> 1. Fugitive dust could be controlled using water sprinkling. Water sprinkling to be carried out by Contract at regular interval (to be mutually decided by the contractor and CMRL). 2. Every vehicle should be washed to remove any dusty materials from its body and wheels before leaving the construction sites. 3. Imposition of speed controls for vehicles on unpaved site roads. Ten kilometers per hour is the recommended limit. 	Contractor	GC/ CMRL
		Waste	Soil and surface/ground water pollution	<ol style="list-style-type: none"> 1. Bentonite slurries used in construction should be reconditioned and reused wherever practicable. 2. The disposal of residual used bentonite slurry should follow the international good practice. 3. Segregation and storage of different types of waste in different containers, skips or stockpiles to enhance reuse or recycling of materials and their proper disposal. 4. Nomination of an approved person, such as a site manager, to be responsible for good site practices, arrangements for collection and effective disposal to an appropriate facility, of all wastes generated at the site. 	Contractor	GC/ CMRL
		Vibration	Pile driving for viaduct piers and buildings and tunnel driving generate vibrations	<ol style="list-style-type: none"> 1. Cast-in-situ piling will be deployed at locations with sensitive receptors so as to reduce vibration. 2. At locations where the alignment is close to sensitive receptors, the contractor shall implement the pre-construction structural integrity inspections. 3. Contractor to ensure that vibration levels at historically and culturally sensitive Structures, and Structures in poor state condition will not exceed 2.0 mm/s. 4. Information dissemination to local residents and shop owners about the nature and duration of intended activities including the construction method, probable effects, quality control measures and precautions prior to 	Contractor	GC/ CMRL

Sl. No.	Activity	Aspect / Parameter affected	Impact	Mitigation measures	Responsibility	
					Implementation	Supervision
				commencement and kept updated as to changes in the management and mitigation plan. 5. Monitoring during construction including field observations and measurements.		
		Physical Cultural Resources	Historic and Cultural Value Loss Conflicts with community	1. Before start of piling and tunneling, Contractor and CMRL will coordinate with State Archeological department to reconfirm that there is presence of buried artifacts along the metro line alignment. No piling or tunneling will be allowed unless cleared by the Archeological Department. 2. Archeological monitoring during construction stage, including specialists in field with authority to stop work. 3. All workers will undergo a briefing with the Archaeology Department to ensure safeguarding of heritage resource and cultural/religious practices. 4. A proof of compliance to this requirement to include the name of participants and date and location of briefing will form part of the monthly report to CMRL. 5. Archeological rescue and protection in case of chance finds, follow specific measures (reporting, monitoring) recommended by UNESCO.	Contractor	GC/ CMRL
		Health & Safety	Noise and vibration generated during piling will affect the health and safety of the workers Accidents	1. Auger piling methods will be used to reduce the impacts of noise. 2m tall screens of GI sheets will be installed between source (pile driver) and receptors (workers & nearby populations). 2. To reduce the harmful effects, personnel working at high noise levels would be provided with noise protective gears such as ear muffers, sound barriers, job rotations per occupational exposure limits etc. 3. Oversight of project safety is needed to ensure proper support and lining of excavated sections to avoid collapse. 4. Where a site boundary adjoins a road, streets or other areas accessible to the public, hoarding should be provided along the entire length except for a site entrance or exit.	Contractor	GC/ CMRL

Sl. No.	Activity	Aspect / Parameter affected	Impact	Mitigation measures	Responsibility	
					Implementation	Supervision
				5. Procedure to receive, evaluate, and compensate (if applicable) damages due to construction and establishment of financial resources to cover this expense.		
22.	Diaphragm Wall Construction	Air	Construction of diaphragm wall will result into fugitive dust generation.	<ol style="list-style-type: none"> 1. Fugitive dust could be controlled using water sprinkling. Water sprinkling to be carried out by Contract at regular interval (to be mutually decided by the contractor and CMRL). 2. Every vehicle should be washed to remove any dusty materials from its body and wheels before leaving the construction sites. 3. Imposition of speed controls for vehicles on unpaved site roads. Ten kilometers per hour is the recommended limit. 	Contractor	GC/ CMRL
		Waste	Soil and surface/ground water pollution	<ol style="list-style-type: none"> 1. Bentonite slurries used in diaphragm wall construction should be reconditioned and reused wherever practicable. 2. The disposal of residual used bentonite slurry should follow the international good practice. 3. Segregation and storage of different types of waste in different containers, skips or stockpiles to enhance reuse or recycling of materials and their proper disposal. 4. Nomination of an approved person, such as a site manager, to be responsible for good site practices, arrangements for collection and effective disposal to an appropriate facility, of all wastes generated at the site. 	Contractor	GC/ CMRL
		Health and Safety	Accidents	<ol style="list-style-type: none"> 1. To specify the number and length of shifts for each worker. 2. Oversight of project safety is needed to ensure proper support and lining of excavated sections to avoid collapse. 3. Tunnels have to be properly lit, drained, and ventilated to provide visibility, dry working conditions, and breathable air free of dust even in confined spaces. 	Contractor	GC/ CMRL

Sl. No.	Activity	Aspect / Parameter affected	Impact	Mitigation measures	Responsibility	
					Implementation	Supervision
				4. Where a site boundary adjoins a road, streets or other areas accessible to the public, hoarding should be provided along the entire length except for a site entrance or exit.		
23.	Excavation (The quantum of soil excavated soil will be about 12.31 lakh cubic meter)	Air	Excavation will result into fugitive dust generation.	<ol style="list-style-type: none"> 1. Fugitive dust could be controlled using water sprinkling. Water sprinkling to be carried out by Contract at regular interval (to be mutually decided by the contractor and CMRL). 2. Imposition of speed controls for vehicles on unpaved site roads. Ten kilometers per hour is the recommended limit. 3. Every vehicle should be washed to remove any dusty materials from its body and wheels before leaving the construction sites. 4. Excavation machinery will be topped up by low-Sulphur fuel. 	Contractor	GC/ CMRL
		Noise and Vibration	Nuisance	<ol style="list-style-type: none"> 1. Efforts should be made to keep the noise levels under control by appropriate noise attenuation and adopting employee safety measures. 2. Use of low-noise equipment and ensuring good maintenance, and trying to avoid using high-noise equipment simultaneously at the same section. 3. Wherever baseline noise already exceeds the standards, only 3dB of noise increase is allowed. 4. Information dissemination to local residents and shop owners about the nature and duration of intended activities including the construction method, probable effects, quality control measures and precautions prior to commencement and kept updated as to changes in the management and mitigation plan. 5. Enclose especially noisy activities if above the noise limits and employ transportable noise screens between noise sources and identified noise sensitive areas for the duration of noisy construction activities. 	Contractor	GC/ CMRL

Sl. No.	Activity	Aspect / Parameter affected	Impact	Mitigation measures	Responsibility	
					Implementation	Supervision
				<ol style="list-style-type: none"> Monitoring required during construction, including field observations and measurements. Provide timely notification of residents about tunneling works will limit the nuisance of noise and vibration due to Tunnel Boring Machine (TBM) operation. Contractor to ensure that vibration levels at historically and culturally sensitive Structures, and Structures in poor state condition will not exceed 2.0 mm/s. 		
		Surface water	Dumping of construction waste like concrete, bricks, waste material etc. cause surface water pollution.	<ol style="list-style-type: none"> Proper drainage systems using contour information will be constructed around active and & large construction sites. The wastewater should be discharged after sedimentation in tanks. To avoid water pollution and soil erosion due to flooding, earthwork will be limited during monsoon season. 	Contractor	GC/ CMRL
		Groundwater	Dewatering (if done) will adversely affect the groundwater regime.	<ol style="list-style-type: none"> Dewatering will be done only when required Groundwater will be collected in sedimentation tanks and reused in non-potable uses. Refer to SHE (Addendum to this EIA report). This water will be treated to meet CPCB standards before discharge. Groundwater monitoring, including groundwater quality and aquifer status. 	Contractor	GC/ CMRL
		Soil	Excavation will adversely affect the soil	<ol style="list-style-type: none"> Soil erosion by runoff will be controlled by installing proper drainage systems using contour information It is suggested to avoid bringing soil from outside the project boundary and to use the excavated mounds for filling low lying area where it is necessary. The topsoil should be preserved (by storing it at appropriate places) so that same can be restored after completion of work. 	Contractor	GC/ CMRL
		Subsidence	Ground subsidence under existing structures during tunneling due to	<ol style="list-style-type: none"> Plan showing location of construction site and affected structures. 	Contractor	GC / CMRL

Sl. No.	Activity	Aspect / Parameter affected	Impact	Mitigation measures	Responsibility	
					Implementation	Supervision
			<p>unanticipated weak pockets of substratum and unanticipated degree of groundwater drawdown, raising safety issues and possible damage to structures</p>	<ol style="list-style-type: none"> 2. Groundwater extraction adjacent the metro project could lead to subsidence under non-metro structures as well as settlement of metro tunnel and stations between Kutcheri Road and Thirumayilai stations, Adyar gate to Alwarpet, Kodambakkam suburban (rock deeper than track level). At abovesaid locations, the bore wells need to be rationalized to avoid groundwater extraction near tunnel. 3. Groundwater drawdown can be minimized by sealing joints in tunnel lining. In addition, where required adjacent structures will be given additional supports. Sides of deep excavations at stations will be supported by walls which minimize water seepage. In open areas where side support walls in excavations are feasible, such walls will help prevent caving and thereby settlement of adjacent structures; in built up areas where side walls are not feasible, adjacent structures will be provided additional supports. 4. Caving of tunnel will be prevented by placing pre-cast concrete segments in soft soils and rock bolts or arch ribs in rock. Subsidence above tunnel due to removal of material and water beneath will be prevented by such tunnel supports. 5. Monitoring records which include but not limited to, groundwater drawdown records from borewells, vibration records, geotagged photographs with date. 6. Real-time monitoring of structures above tunneling operations and adjustments of TBM operation if required. 7. Record sheet showing type, size and identification number of structure, time of occurrence, type of equipment in use before and when the damage was first noticed, the type of minor repair executed, number of occupants present and evacuated, time of evacuation, status of adjacent structures, type of rehabilitation implemented on each affected structure, date of 		

Sl. No.	Activity	Aspect / Parameter affected	Impact	Mitigation measures	Responsibility	
					Implementation	Supervision
				resumption of construction activities, date of return of occupants.		
		Physical Cultural Resources	Historic and cultural value loss Conflicts with community	<ol style="list-style-type: none"> 1. Before start of excavation, Contractor and CMRL will coordinate with State Archeological department to reconfirm that there is presence of buried artifacts along the metro line alignment. No excavation will be allowed unless cleared by the Archeological Department. 2. Archeological monitoring during construction stage, including specialists in field with authority to stop work. 3. All workers will undergo a briefing with the Archaeology Department to ensure safeguarding of heritage resource and cultural/religious practices. 4. A proof of compliance to this requirement to include the name of participants and date and location of briefing will form part of the monthly report to CMRL. 5. Archeological rescue and protection in case of chance finds, follow specific measures (reporting, monitoring) recommended by UNESCO. 	Contractor	GC/ CMRL
		Health and Safety	Accidents	<ol style="list-style-type: none"> 1. To specify the number and length of shifts for each worker. 2. Oversight of project safety is needed to ensure proper support and lining of excavated sections to avoid collapse. 3. Tunnels have to be properly lit, drained, and ventilated to provide visibility, dry working conditions, and breathable air free of dust even in confined spaces. 4. Where a site boundary adjoins roads, streets or other areas accessible to the public, hoarding should be provided along the entire length except for a site entrance or exit. 	Contractor	GC/ CMRL
		Aesthetics	Loss of aesthetics value due to excavation and related activities.	<ol style="list-style-type: none"> 1. The excavation sites will be barricaded on all sides using GI sheets. Hauling will be carried out in non-peak hours. 2. Aesthetic value of the site will be restored after completion of the works. 	Contractor	GC/ CMRL

Sl. No.	Activity	Aspect / Parameter affected	Impact	Mitigation measures	Responsibility	
					Implementation	Supervision
24.	Blasting	Aesthetics	Blasting will raise aesthetics issues among local citizen	<ol style="list-style-type: none"> 1. Rock is found in lower part of tunnel or beneath track level and so blasting is not anticipated. Good housekeeping practice should be adopted. 2. In the unforeseen event that blasting is required, a site-specific EMP will be prepared by Contractor and approved by CMRL before blasting commencement. 	Contractor	CMRL/ GoTN
25.	Hauling of excavated material	Air	During transportation of excavated material, fugitive dust will be generated from two sources, (1) from re-suspension of dust from road surface, (2) from the movement of air, against the excavated material being hauled	<ol style="list-style-type: none"> 1. The traffic management plan will be stringently implemented with regular monitoring and inspections. 2. The trucks/dumpers carrying the excavated material will be covered using tarpaulin/similar covering materials. 3. Sprinkling of water should be carried out. 4. Truck tires will be washed to excess remove soil clinging to it. Contractor will provide a wash pit or a wheel washing and/or vehicle cleaning facility at the exits from construction depots and batching plants. At such facility, high-pressure water jets will be directed at the wheels of vehicles to remove all spoil and dirt. 5. Water for sprinkling and tire washing will be sourced from treated effluent from ETPs located nearby or seawater or surface runoff. Groundwater will not be used in view of status in Chennai. 6. Haul roads will be kept in good state of maintenance. 	Contractor	GC/ CMRL/ GoTN
		Noise	Dumper trucks carrying excavated material will result into high noise (typically in excess of 85 dB (A) at one m distance, or 57 dB (A) at 10 m distance). The adverse impacts of noise will be most intense in the residential / urban areas.	<ol style="list-style-type: none"> 1. The routing, timing and logistics of the haul truck movement should be planned to have minimal impacts on noise level. 2. The route selection will avoid any sensitive receptors. 3. Efforts should be made to keep the noise levels under control by appropriate noise attenuation and adopting employee safety measures. 4. Wherever baseline noise already exceeds the standards, only 3dB of noise increase is allowed. 5. Information dissemination to local residents and shop owners about the nature and duration of intended activities including the construction method, probable 	Contractor	GC/ CMRL

Sl. No.	Activity	Aspect / Parameter affected	Impact	Mitigation measures	Responsibility	
					Implementation	Supervision
				<p>effects, quality control measures and precautions prior to commencement and kept updated as to changes in the management and mitigation plan.</p> <p>6. Enclose especially noisy activities if above the noise limits and employ transportable noise screens between noise sources and identified noise sensitive areas for the duration of noisy construction activities.</p> <p>7. Monitoring required during construction, including field observations and measurements.</p>		
		Social	Incessant movement of trucks could create social issues. This will have higher occurrences near depots.	<p>1. The local community has to be taken into confidence before the construction commences. Their advice must be taken and incorporated in decision making.</p> <p>2. Grievance Redress Mechanism for affected people should function effectively with grievance log well documented.</p>	Contractor	GC/ CMRL
		Health & Safety	The movement of trucks will increase the traffic risk of the commuters.	1. The routing, timing and logistics of the haul truck movement should be planned to have minimal impact on occupational and community health and safety.	Contractor	GC/ CMRL
26.	Dumping of excavated materials	Air	The dumping operation of excavated material will generate fugitive dust in the nearby areas	<p>1. Site of dumping shall be selected by Contractor in consultation with CMRL and authorities.</p> <p>2. The disposal plan will be stringently implemented with site monitoring and inspections.</p> <p>3. It will be located outside of urban habitation.</p> <p>4. Sprinkling of water should be carried out.</p>	Contractor / GC	CMRL /CMDA/ Chennai Municipal Corporation
		Soil	Dumping may increase the height of the land and affect the natural drainage pattern of the area	<p>1. The dumping shall be done in pre-designated low lying areas which are to be identified by Contractor in consultation with CMDA, TNPCB, and CMRL for this specific purpose.</p> <p>2. The disposal plan will be stringently implemented with regular monitoring and inspections.</p> <p>3. Field inspections, monitoring, and documentation of dumping excavated materials.</p>	Contractor	GC/ CMRL

Sl. No.	Activity	Aspect / Parameter affected	Impact	Mitigation measures	Responsibility	
					Implementation	Supervision
27.	Traffic diversion	Air	The under construction areas will be restricted for human and vehicular movements. This will result in detouring of vehicles and/or pedestrians, on the project line which passes through busy urban areas. This may also result into traffic congestion and air pollution from stagnated vehicles in urban areas. Primary pollutants will be Nox, CO, NMHC, and VOCs.	<ol style="list-style-type: none"> 1. Permission from Chennai Traffic Police will be sought before commencement of work. Detours will be properly planned and enacted during non-peak hours only, if possible. Traffic marshals will be posted near such detours. Proper signage has to be posted informing motorists about detours following IRC norms. 2. Adaptive management with field inspections and monitoring during plan implementation and adjustments, as needed, to reflect actual traffic congestion or related issues 3. The Contractor will discuss and coordinate the implementation of the traffic re-routing scheme particularly at station area when it starts the cut and cover activities and the hauling and disposal of excavated materials to the project sites. 	Contractor	GC/ CMRL
		Noise	Barricading & detouring may result into traffic congestion in the urban areas. This will result into (a) noise from vehicular movement and (b) honking noise due to congestion.	<ol style="list-style-type: none"> 1. Permission from Traffic police will be sought before commencement of work. Detours will be properly planned and enacted during non-peak hours only, if possible. Traffic marshals could be posted near busy intersections, to oversee the smooth flow of traffic. 2. Detour route selection to avoid sensitive receptors to noise. 3. Adaptive management with field inspections and monitoring during plan implementation and adjustments, as needed, to reflect actual traffic congestion or related issues. 	Contractor	GC/ CMRL
		Social	Traffic diversion (especially For public transport) will create inconvenience	<ol style="list-style-type: none"> 1. Implement the traffic management plan. Plans will be made to spare traffic diversion during peak hours (morning and evening peaks). Also separate arrangements for bus, auto and taxi parking bays will be made. Street furniture for pedestrians will be provided wherever possible. 	Contractor	GC/ CMRL

Sl. No.	Activity	Aspect / Parameter affected	Impact	Mitigation measures	Responsibility	
					Implementation	Supervision
				2. Real-time communication to public prior to site-specific work (for example, via signs, radio, and newspaper) and during key periods of traffic interference or peak traffic. 3. Adaptive management with field inspections and monitoring during plan implementation and adjustments, as needed, to reflect actual traffic congestion or related issues.		
		Resource consumption	Detouring will increase the road length to be travelled by a car, thus, increasing the overall fuel consumption.	1. The detour will be planned to be optimum in terms of road length. The faster completion of works will also tend to reduce enhanced fuel consumption.	Contractor	GC/ CMRL / GoTN
28.	Restricted pedestrian movement	Social	Restricted pedestrian movement will cause social uproar, esp. in people living near metro stations	1. Safe passage for pedestrians with proper sunshade / fall protection and signage will be planned. Public consensus will be built. 2. Grievance Redress Mechanism for affected people should function effectively with grievance log well documented.	Contractor	GC/ CMRL
		Health & Safety	Movement though constricted space may cause potential health & safety issues amongst pedestrians	1. Safe passage for pedestrians with proper fall protection and signage will be planned.	Contractor	GC/ CMRL
29.	Muck generation & disposal (incl. spent Bentonite & drill fluid and slurry)	Surface water	Muck generated incl. spent Bentonite & slurry from drilling operations will drain with surface runoff and pollute nearby water bodies	1. Muck disposal plan will be stringently implemented with regular monitoring and inspections. 2. The construction sites will be provided with garland drains with intercepting pits to trap silt & muck. 3. Muck will be stored in lined tanks / ponds (if such area is available). Or mechanically dewatered if such area is unavailable. After screening & detention, supernatant liquid from such tanks should be discharged into drainage lines adhering to CPCB standards. Such tank/ ponds could be covered during monsoon to control runoff.	Contractor	GC/ CMRL

Sl. No.	Activity	Aspect / Parameter affected	Impact	Mitigation measures	Responsibility	
					Implementation	Supervision
				4. The temporary muck storage areas will be maintained by the Contractor at all times until the excavate is re-utilized for backfilling or disposed of as directed by Employer. Dust control activities will continue even during any work stoppage 5. Transportation of muck will be scheduled by time and route to minimize air pollution in habitat areas.		
		Groundwater	Muck, spent bentonite & drill fluids may settle down from pond / tanks and will affect groundwater	1. The tanks/ ponds holding muck will be lined to prevent infiltration into groundwater. 2. Groundwater quality monitoring.	Contractor	GC/ CMRL
		Aesthetics	Muck generation will create an aesthetic issue	1. The construction site will be covered from all sides to reduce visual impacts.	Contractor	GC/ CMRL
30.	Raft foundation	Soil	Construction of raft foundation will generate concrete spoils. This will have adverse effects on soil	1. Concrete spoils will be collected manually and will be disposed in proposed disposal grounds.	Contractor	GC/ CMRL
31.	Steel structure preparation	Soil	Steel structure preparation will create steel scraps	1. Steel scrap will be collected, sorted by diameter and sold to scrap dealers on later date.	Contractor	GC/ CMRL
		Health & safety	Bar bending & other activities (including Working at heights) might pose a H&S threat to workers	1. Workers will be provided appropriate hand gloves and personal protective equipment (PPE). 2. Skilled workers working at height or doing hot work will be required to seek permission from site	Contractor	GC/ CMRL
32.	Stacking & warehousing	Surface water	Washed out raw material could pose serious threat to surface water bodies	1. Small dikes and garlanding drains along the periphery of the yard and ploy boundary could be constructed. This will control runoff and washing out of finer material.	Contractor	GC/ CMRL / GoTN

Sl. No.	Activity	Aspect / Parameter affected	Impact	Mitigation measures	Responsibility	
					Implementation	Supervision
	of raw material	Soil	Spillage of materials / mix products on the ground could pollute soil	1. Proper care will be taken. Such spills will be cleared by scraping and disposing the products as road sub-grade material.	Contractor	GC/ CMRL
		Health & Safety	Fine products like cement/ silt/ sand could cause harm to respiratory system.	1. Cement and sand will be stacked under tarpaulin and secured by GI sheet barricading (working & wind break). Shorter work shift and daily medical checkups of workers will be implemented. 2. Dust filters atop cement silos, wet suppression for aggregate crushing and screening will be employed.	Contractor	GC/ CMRL
		Aesthetics	Stacking of raw material will cause aesthetic issues for residential areas located nearby	1. The height of walls between the residential area and RM yard / construction area will be raised using GI sheets.	Contractor	GC/ CMRL
33.	RCC pouring (using concrete pump)	Noise	RCC pouring using concrete pump will generate low frequency rumbling noise. This will be more perceived and irritating in residential areas.	1. Timing of using RCC pumps will be specified. 2. RCC pumps will be covered from all sides. 3. Bends and excessive head will be avoided. 4. Wherever baseline noise already exceeds the standards, only 3dB of noise increase is allowed.	Contractor	GC/ CMRL
		Soil	Spillage from concrete pouring may contaminate soil	1. The spoils from pouring concrete will be collected and reused as sub-grade material in road construction.	Contractor	GC/ CMRL
		Aesthetics	Spoils from concrete pouring will create unpleasant looking visuals	1. After each pouring cycle, the spoils will be manually collected and reused as sub-grade material in road construction.	Contractor	GC/ CMRL

Sl. No.	Activity	Aspect / Parameter affected	Impact	Mitigation measures	Responsibility	
					Implementation	Supervision
34.	Setting of concrete (using needle vibrator)	Noise	Needle vibrators generate low frequency noise when dipped in concrete and high frequency noise when raised. Sound level vary between 82-93 dB (A).	<ol style="list-style-type: none"> 1. If the consistency of concrete could be altered, the need for use of vibrator (esp. in low temperature & low thickness casting) could be reduced. Damping could be used to reduce high frequency noise, and thereby reducing the noise levels. Workers should be provided with suitable PPEs. 2. Wherever baseline noise already exceeds the standards, only 3dB of noise increase is allowed per IFC/WB guideline. 	Contractor	GC/ CMRL / GoTN
		Soil	During setting, spillage from cast could take place.	<ol style="list-style-type: none"> 1. The spoils from pouring concrete will be collected and reused as sub-grade material in road construction. 	Contractor	GC/ CMRL
35.	Curing of concrete (use of water)	Surface water	Curing water will drain to the low lying areas and pollute water courses	<ol style="list-style-type: none"> 1. Garland drainage is proposed to be constructed around the construction yard. This will intercept the runoff generated from site. Rainwater harvesting (as a compensatory measure) will be practiced. 	Contractor	GC/ CMRL / GoTN
		Groundwater	Curing water will drain to the low lying areas and pollute water courses	<ol style="list-style-type: none"> 1. In view of low groundwater levels and proximity of sea coast, use of groundwater will not be resorted to. 	Contractor	GC/ CMRL
		Aesthetics	Curing will create water impounding and may lead to vector propagation	<ol style="list-style-type: none"> 1. Garlanding drain will be constructed around the construction area. The curing water impounded will be reused for curing. 	Contractor	GC/ CMRL
36.	Use of Crane & Launchers	Noise	Operation of launchers and crane will generate noise which in times may go up to 85-90 dB (A). Legris & Poulin ²⁰ has found that the average daily noise exposure was 138 dBA. 84 to 99 dB (A) for heavy	<ol style="list-style-type: none"> 1. The sensitive receptors (workers & external parties, if applicable) have to be isolated from heavy construction noise generated. This is possible by erecting reinforced 2 m tall GI sheet barrier around the area where heavy construction works is undertaken. 2. Workers working inside or near construction equipment should be provided with proper PPEs like ear plugs / muffs complying with IS 4869. 	Contractor	GC/ CMRL

²⁰ Legris, M., and P. Poulin: Noise exposure profile among heavy equipment operators, associated labourers and crane operators. Am. Ind. Hyg. Assoc. J, pp.774-778, 1998.

Sl. No.	Activity	Aspect / Parameter affected	Impact	Mitigation measures	Responsibility	
					Implementation	Supervision
			equipment, and 74 to 97 dB (A) for the crane operators.	<ol style="list-style-type: none"> Wherever baseline noise already exceeds the standards, only 3dB of noise increase is allowed. Information dissemination to local residents and shop owners about the nature and duration of intended activities including the construction method, probable effects, quality control measures and precautions prior to commencement and kept updated as to changes in the management and mitigation plan. Enclose especially noisy activities if above the noise limits and employ transportable noise screens between noise sources and identified noise sensitive areas for the duration of noisy construction activities. 		
		Health & Safety	Cranes and launchers are a major safety concern.	<ol style="list-style-type: none"> As per SHE, operation of launchers and cranes should be only done under the strict supervision of a qualified engineer and a safety supervisor. Only qualified & trained crane/ launcher operators should be allowed. Proper examination of crane, launchers, labours & operators should take place before commencement of work. 	Contractor	GC/ CMRL
37.	Construction of labour camp(s) and associated environmental issues	Surface water	Sewage from labour camps may be discharged into open slopes thus contaminating surface water	<ol style="list-style-type: none"> Labour camps will be constructed in semi urban / urban set-ups. Thus, sewage and other discharges from the labour camps will be discharged in public sewers or septic tanks should be provided where access to public sewers is not possible. 	Contractor	GC/ CMRL
		Groundwater	Surface water on flat terrain could percolate and contaminate groundwater.	<ol style="list-style-type: none"> Contractor to collect the groundwater baseline data prior to construction. Disposal in compliance with applicable regulatory requirements. Groundwater quality monitoring. Water abstracted must be measured/ recorded periodically. After Construction, Contractor will conduct groundwater analysis and be obliged to reinstate the used sites no worse than the conditions of pre-construction. 	Contractor	GC/ CMRL

Sl. No.	Activity	Aspect / Parameter affected	Impact	Mitigation measures	Responsibility	
					Implementation	Supervision
		Soil	Solid waste generated from the labour camps will cause soil pollution	<ol style="list-style-type: none"> 1. Contractor to collect the soil baseline data prior to construction. 2. Municipal solid waste will be collected and taken away and disposed by municipality. 3. Solid waste will have to be disposed in compliance with Municipal Solid Waste (Management & Handling) Rules, 2000, as amended to date. 4. After Construction, Contractor will conduct soil analysis and be obliged to reinstate the used sites no worse than the conditions of pre-construction. 	Contractor	GC/ CMRL
		Social	Influx of non-local labours will create a social issue	<ol style="list-style-type: none"> 1. Mixing of skilled non-local labours with local unskilled people will reduce social frictions. 2. To avoid labor influx risk, sensitizing of local community and the non-local workers separately as well as jointly will be done regularly. 	Contractor	GC/ CMRL
		Health & safety	Living in congested condition, make-shift temporary arrangement; the labours are prone to diseases.	<ol style="list-style-type: none"> 1. Regular counselling, medical checkups and treatment at separate clinics, coordination with local health authorities will be conducted. 2. Per Building & Other Construction Workers (BOCW Regulation of Employment and Conditions of Service) Act, 1996 the employer (contractor) is liable to arrange for sanitation, health care facilities of labours, free of charge. Labour camps will be in full compliance of BOCW Act. 	Contractor	GC/ CMRL
		Resources	Labours will consume resources like wood for cooking	<ol style="list-style-type: none"> 1. Liquid petroleum Gas cylinders will be made available free of cost to the labourers by the Contractor. 2. Labour camps shall be provided with canteen facility. 	Contractor	GC/ CMRL
38.	Loading /unloading of construction material	Air	Loading & unloading of construction material will generate fugitive dust	<ol style="list-style-type: none"> 1. The traffic management plan will be stringently implemented with regular monitoring and inspections. 2. The trucks/dumpers carrying the material will be covered using tarpaulin/similar covering materials. 3. Fugitive dust could be controlled using water sprinkling. Contractors should carry out water sprinkling. 	Contractor	GC/ CMRL

Sl. No.	Activity	Aspect / Parameter affected	Impact	Mitigation measures	Responsibility	
					Implementation	Supervision
				4. Truck tires will be washed to excess remove soil clinging to it. Contractor will provide a wash pit or a wheel washing and/or vehicle cleaning facility at the exits from construction depots and batching plants. At such facility, high-pressure water jets will be directed at the wheels of vehicles to remove all spoil and dirt.		
		Noise	Loading & unloading of construction material will generate noise	<ol style="list-style-type: none"> 1. The RM storage yard will be separately built and enclosed from all sides. This will reduce noise generation at site. 2. Concrete preparation will only take place in casting yards (away from habitation). 3. Wherever baseline noise already exceeds the standards, only 3dB(A) of noise increase is allowed. 4. Information dissemination to local residents and shop owners about the nature and duration of intended activities including the construction method, probable effects, quality control measures and precautions prior to commencement and kept updated as to changes in the management and mitigation plan. 5. Enclose especially noisy activities if above the noise limits and employ transportable noise screens between noise sources and identified noise sensitive areas for the duration of noisy construction activities. 	Contractor	GC/ CMRL
		Health & safety	Fugitive dust and noise generation will have potential health & Safety implications.	1. Cement and sand will be stacked under tarpaulin and secured by GI sheet barricading (working & wind break). Shorter work shifts and regular health checkups will be implemented. The RM storage yard will be separately built and enclosed from all sides. The worker will be provided with suitable PPEs. Also they will be trained and encouraged in using PPEs.	Contractor	GC/ CMRL
39.	Use of batching plant	Air	Loading & unloading of construction material into batching plant will generate fugitive dust	1. High GI sheet screens and water sprinkling will be employed.	Contractor	GC/ CMRL

Sl. No.	Activity	Aspect / Parameter affected	Impact	Mitigation measures	Responsibility	
					Implementation	Supervision
				2. Batching plant / casting yard shall be barricaded and made as a compulsory PPE zone. This will effectively reduce the fugitive dust generation.		
		Noise	Operation of batching plant will generate noise	<ol style="list-style-type: none"> GI sheet barricading around batching area and worker PPE like ear muffs will be used. Batching plant / casting yard shall be barricaded and made as a compulsory PPE zone. This will reduce the impacts of noise generation. Wherever baseline noise already exceeds the standards, only 3dB of noise increase is allowed. 	Contractor	GC/ CMRL
		Soil and Groundwater	Runoff of waste can contaminate soil and groundwater	<ol style="list-style-type: none"> Contractor to collect baseline soil and groundwater quality data prior to operate the plants. Municipal water will be used. In view of fragile groundwater status, extraction will be avoided. The construction sites will be provided with drains with intercepting pits in which the cement and sand will settle. After screening & detention, liquid will be discharged into drainage lines. Disposal in compliance with applicable regulatory requirements. Soil and Groundwater quality monitoring. After Construction, Contractor will conduct soil and groundwater analysis and be obliged to reinstate the used sites no worse than the conditions of pre-construction. 	Contractor	GC/ CMRL
		Hazardous waste	Health impacts and soil and groundwater pollution from hazardous water at batching/casting yards	<ol style="list-style-type: none"> The use and storage of hazardous materials at the casting yard and batching plant should adhere to TNPCB requirements. The transport, handling and storage of hazardous waste will be done in accordance with the provisions of Hazardous Chemicals (Management & Handling) Rules. Hazardous wastes from construction activity and equipment are labeled, recorded, stored in impermeable containment and for periods not exceeding mandated 	Contractor	GC/ CMRL

Sl. No.	Activity	Aspect / Parameter affected	Impact	Mitigation measures	Responsibility	
					Implementation	Supervision
				<p>periods and in a manner suitable for handling storage and transport.</p> <ol style="list-style-type: none"> The contractor shall maintain a record of sale, transfer, storage of hazardous waste and make these records available for inspection. The contractor shall get Authorized Recyclers to transport and dispose Hazardous Waste. Proper collection and storage facilities will be provided especially for hazardous waste. 		
		Resources	<p>If the batching plant will get its power from DG sets, substantial diesel will be consumed.</p> <p>(A 30 m³/hr. batching plant will require 143 ignali. 60 KW/hr. (or, 143 ignali. 75 KVA, assuming PF = 0.8) energy. In most cases the Contractor has used DG sets (from 100 – 250 kVA) for batching plant & ancillary facilities. Thus, the diesel req. will range from 30 – 45L/hr, at 100% load)</p>	<ol style="list-style-type: none"> If power from the grid is used, permission from power supply company must be obtained by the Contractor. DG sets, if used, should: (a) conform to height of stack norms as per CPCB rules; (b) conform to emission norms as per E (P) Act, 1986; (c) noise level at 1 m distance from enclosure should not be >75 dB(A). The required permissions from local Environmental Authorities/Pollution Control Board/ CEIG or any other relevant Authority shall be obtained by the Contractor for using DG sets for power supply. Diesel storage if done beyond threshold limit (1000 L) permission should be obtained. Diesel should be stored on pukka platforms and spillages should be avoided. Refer to Activity 42 “Use of DG sets” and Activity 44 “Storage of Diesel” for further measures. 	Contractor	GC/ CMRL
40.	Casting of segments and I-beams	Groundwater	Casting will require use of water	<ol style="list-style-type: none"> Chennai Metropolitan Water Supply and Sewerage Board /Municipal water will be used. In view of fragile groundwater status, extraction will be avoided. The construction sites will be provided with drains with intercepting pits in which the cement and sand will settle. After screening & detention, liquid will be discharged into drainage lines. Disposal in compliance with applicable regulatory requirements. Groundwater quality monitoring. 	Contractor	GC/ CMRL

Sl. No.	Activity	Aspect / Parameter affected	Impact	Mitigation measures	Responsibility	
					Implementation	Supervision
		Resources	Casting (incl. operation of gantry and hydraulic pre-stressing units) will consume lot of energy	1. Pre-stressing and casting are basic requirements. However, most of the power should be drawn from approved lines, not from DG sets.	Contractor	GC/ CMRL
41.	Curing of segments & I-beams	Groundwater	Curing will require a significant amount of water	<ol style="list-style-type: none"> 1. Wastages from curing could be collected separately and reused if possible. Stagnation of water (and resultant vector propagation) should be avoided. 2. Groundwater quality monitoring. 3. Disposal in compliance with applicable regulatory requirements 4. Groundwater will not be used. Water will be sourced from municipal supply or treated effluent from ETPs or treated surface runoff. 	Contractor	GC/ CMRL
42.	Hauling of segments to site	Air	During transportation of segments, fugitive dust will be generated from re-suspension of dust from road surface. Plus, there will be air emission from trucks	<ol style="list-style-type: none"> 1. The traffic management plan will be stringently implemented with regular monitoring and inspections. 2. The trucks/dumpers carrying the excavated material will be covered using tarpaulin/similar covering materials. 3. Sprinkling of water should be carried out. 4. Truck tires will be washed to excess remove soil clinging to it. Contractor will provide a wash pit or a wheel washing and/or vehicle cleaning facility at the exits from construction depots and batching plants. At such facility, high-pressure water jets will be directed at the wheels of vehicles to remove all spoil and dirt. 5. Haul roads will be kept in good state of maintenance. 	Contractor	GC/ CMRL
		Noise	Trucks carrying segments will result into high noise (typically in excess of 85 dB(A) at 1 m distance, or 57 dB(A) at 10 m distance). The adverse impacts of noise will be most intense in the residential/urban areas	<ol style="list-style-type: none"> 1. The routing, timing and logistics of the haul truck movement should be planned to have minimal impacts on noise level. The route selection will avoid any sensitive receptors. 2. Efforts should be made to keep the noise levels under control by appropriate noise attenuation and adopting employee safety measures. 	Contractor	GC/ CMRL

Sl. No.	Activity	Aspect / Parameter affected	Impact	Mitigation measures	Responsibility	
					Implementation	Supervision
				<ol style="list-style-type: none"> 3. Wherever baseline noise already exceeds the standards, only 3dB of noise increase is allowed. 4. Information dissemination to local residents and shop owners about the nature and duration of intended activities including the construction method, probable effects, quality control measures and precautions prior to commencement and kept updated as to changes in the management and mitigation plan. 5. Enclose especially noisy activities if above the noise limits and employ transportable noise screens between noise sources and identified noise sensitive areas for the duration of noisy construction activities. 6. Monitoring required during construction, including field observations and measurements. 		
		Social	Incessant movement of trucks could create social issues	<ol style="list-style-type: none"> 1. The local community has to be taken into confidence. Their advice has to be taken and incorporated in decision making. 	Contractor	GC/ CMRL
		Health & safety	The movement of trucks will increase the traffic risk of the commuters	<ol style="list-style-type: none"> 1. The routing, timing and logistics of the haul truck movement will be planned to have minimal impacts on occupational and community health and safety. 	Contractor	GC/ CMRL
		Aesthetics	Movement of trucks will create an aesthetic problem	<ol style="list-style-type: none"> 1. Proper housekeeping activities have to be undertaken near the casting yard and nearby areas. 	Contractor	GC/ CMRL
43.	Use of DG sets	Air	Emission of NO _x , SO _x , CO, PM ₁₀ , PM _{2.5} from DG sets will create air pollution problems	<ol style="list-style-type: none"> 1. Primary power source will be power distribution company, DG sets will be used only for power back-ups for stations. 2. The required permissions from local Environmental Authorities/Pollution Control Board/ CEIG or any other relevant Authority shall be obtained by the Contractor if using DG sets for power supply. DG sets compliant with CPCB norms will be used. Specification no. GSR 520(E) dt. 1-7-2003 for DG sets rating < 800 KW, and GSR 489(E) dt. 09-07-2002 for DG sets > 800 KW under E (P) Rules, 1986. 	Contractor	GC/ CMRL

Sl. No.	Activity	Aspect / Parameter affected	Impact	Mitigation measures	Responsibility	
					Implementation	Supervision
				<ol style="list-style-type: none"> 3. Stack height of DG sets will be as per CPCB requirement [stack ht. = 0.2*(rating in kVA)0.5] 4. Stack monitoring will be conducted monthly of the criteria pollutants. 5. Compliance monitoring will be done to the regularly and check the monitoring instruments. 6. Fuels used for DG will be High Speed Diesel with low-sulfur content. 		
		Noise & Vibration	Noise & vibration will be generated from the use of DG sets	<ol style="list-style-type: none"> 1. DG sets compliant with CPCB norms will be used. 2. Wherever baseline noise already exceeds the standards, only 3dB of noise increase is allowed. 3. Monitoring required during construction, including field observations and measurements. 4. DG sets will be enclosed type, with noise level approx. 75 dB (A) at a distance of 1m in compliance with GSR 371(E) dt. 17-05-2002. 5. Noise will be controlled using acoustic enclosure. 6. The DG sets will be mounted on damping skids, which will reduce the vibration generated from DG sets. 	Contractor	GC/ CMRL
		Resources	DG sets will consume Diesel (and in effect reduce the levels of a non-renewable resource)	<ol style="list-style-type: none"> 1. DG sets should always be used as a power back up, and not the primary sources of power. This should be made mandatory for all Contractors. 2. Refer to Activity 44 "Storage of Diesel" for further measures. 	Contractor	GC/ CMRL
		Aesthetics	Operation of DG sets will cause an aesthetic issue	<ol style="list-style-type: none"> 1. Enclosures will be used to keep them off from public views. 2. PM content of DG sets smoke will be as per the CPCB norms, thus the DG will emit dark smoke only during start-up & shut-down (b) Noise will be controlled using acoustic enclosure. 	Contractor	GC/ CMRL

Sl. No.	Activity	Aspect / Parameter affected	Impact	Mitigation measures	Responsibility	
					Implementation	Supervision
44.	All Construction Activities	Environment	Construction and Demolition (C&D) waste results from land clearing, excavation, construction, demolition, remodeling and repair of structures, roads and utilities	<ol style="list-style-type: none"> 1. Records of movement and loading/unloading of C&D waste and records of waste loaded by vendors. 2. C&D waste will be reused/recycled as it has the potential to save natural resources (stone, river sand, soil etc.) and energy. C&D waste generated from metro construction has potential use after processing and grading. 3. The contractor will segregate and temporarily store the C&D waste till the vendor takes it away for recycling and disposal at authorized facilities. 4. Contractor will adhere with the C&D Waste Management Rules. 	Contractor	GC/ CMRL
		Occupational Health and Safety	Accidents All parties' reputation	<ol style="list-style-type: none"> 1. Worker safety is important on all construction projects. It is important to consider the effects of staffing on worker safety and to provide appropriate training in safety awareness for all labor. 2. For underground construction, it is very important to conduct a fatigue assessment and to specify the number and length of shifts for each worker. Oversight of project safety is needed to ensure that tunneling is completed in suitable soil and drainage conditions and with proper support and lining of excavated sections to avoid collapse. Apart from the stringent inspection, tunnels have to be properly lit, drained, and ventilated to provide visibility, dry working conditions, and breathable air free of dust even in confined spaces. 3. The use of hearing protection should be enforced actively when the equivalent sound level over 8 hours reaches 85 dB(A), the peak sound levels reach 140 dB(C), or the average maximum sound level reaches 110dB(A). Hearing protective devices provided should be capable of reducing sound levels at the ear to at least 85 dB(A). 	Contractor	GC/ CMRL
45.	Storage of Diesel	Groundwater	Diesel spillage (from underground or above ground storage facility) will	<ol style="list-style-type: none"> 1. Before it percolates into the groundwater, contaminated runoff water can be run through adsorbents such as bentonite to remove the diesel. The diesel will be quickly 	Contractor	GC/ CMRL

Sl. No.	Activity	Aspect / Parameter affected	Impact	Mitigation measures	Responsibility	
					Implementation	Supervision
			affect groundwater quality adversely	<p>collected into steel trays and disposed to authorized recyclers.</p> <p>2. All bulk diesel tanks shall be properly supported in an elevated position to facilitate gravity discharge. They shall stand within a bund constructed to contain a volume of 110% of the volume of the tank. There shall be no breaches in the bund wall, no material shall be stored within the bund and rain water collecting in the bund shall be regularly removed to prevent build-up.</p> <p>3. Spillage will be controlled using methods mentioned in the environmental contingency plan.</p> <p>4. Groundwater quality monitoring.</p>		
		Health & safety	Storage of Diesel will attract the provisions of Hazardous Chemicals (Management & Handling) Rules and Petroleum Rules; as amended to date. It could cause serious damage to health & safety of workers / property if ignited	<p>1. Proper onsite emergency plan will be prepared and will be approved through CMRL.</p> <p>2. If the diesel storage crosses the threshold limits permissions, proper fire protection norms have to be undertaken as per National Building Code, 2005 (if building)/ Oil Industry Safety Directorate Standard 117 (if installation).</p>	Contractor	GC/ CMRL
46.	Cleanup Operations, Restoration and Rehabilitation	Environment	Aesthetics	<p>1. The clean-up and restoration operations are to be implemented by the Contractor prior to demobilization. All spaces excavated and not occupied by the foundation or other permanent works shall be refilled with earth up to surface of surrounding ground.</p>	Contractor	GC/ CMRL
Operational Phase						

Sl. No.	Activity	Aspect / Parameter affected	Impact	Mitigation measures	Responsibility	
					Implementation	Supervision
47.	Operation of metro trains	Noise and Vibration	The most significant source of noise will be rolling noise from contact between wheel and rail including noise from contact between the brake pad and wheel, followed by engine noise and aerodynamic noise.	<ol style="list-style-type: none"> To minimize operation stage impacts measures such as Ballast less track structure is supported on two layers of rubber pads to reduce noise and vibrations. In addition, baffle wall as parapets will be constructed up to the rail level so as reduce sound levels. Noise at source will be controlled or reduced by incorporating suitable feature in the design of structures and layout of machines and by use of resilient mounting and dampers etc. Considering that the train generate a rolling noise of approx. 85 dB(A) at a ht. of approx. 8-12 m, the additional noise level will be approx. 55 - 60 dB(A) at a ht. of 1.5 m on ground. The noise level will be further reduced due to directivity, and conversion of frictional energy. The noise level at the bottom of the line will be insignificant and could be marginally different from ambient (traffic) noise. Since the rakes will be air conditioned and enclosed from all side, the impacts of noise on the travelers will be nominal. Noise barriers will be installed at locations based on final design noise prediction analysis. Wherever baseline noise already exceeds the standards, only 3dB of noise increase is allowed. The mitigations suggested based on the detailed noise and vibration analysis carried out prior to commencement of construction, should be strictly followed. 	GC / CMRL	GoTN
		Health and Safety	Accidents Reputational risks	<ol style="list-style-type: none"> Detailed specification of equipment e.g. power cables, rectifiers, transformer, E&M equipment etc. shall be framed to reduce conducted or radiated emissions as per appropriate international standards. The Metro system as a complete vehicle (trains, signaling & telecommunication, traction power supply, E&M system etc.) shall comply with the Electromagnetic compatibility (EMC) requirements of international standards viz. EN50121-3-1, EN50123, IEC61000 series etc. EMC requirements of international standards for whole railway 	GC / CMRL	GoTN

Sl. No.	Activity	Aspect / Parameter affected	Impact	Mitigation measures	Responsibility	
					Implementation	Supervision
				<p>system to the outside world shall comply with EN50121-2.</p> <ol style="list-style-type: none"> A standby silent type DG set of adequate capacity at underground stations will sustain the following: essential lighting, signaling, and telecommunications, fire-fighting system, lift operation, and tunnel ventilation. Automatic Train Protection and Automatic Train Supervision sub-systems will be installed to provide a high level of safety. CCTV system will be installed for local and centralized monitor of operation. In view of the potential hazards from system failure resulting to accidents, both on-site and off-site emergency measures will be implemented. All trains will have public address systems to warn the passengers of any emergency. Emergency team, ambulance, contact number and hospital should be available. Emergency response plan should be implemented during operation periods. 		
		Aesthetics	Metro rail will increase the aesthetics of Chennai	1. A proper housekeeping routine will be followed to enhance the aesthetics of metro rail station & depot.	GC / CMRL	GoTN
48.	Maintenance of trains in Depot	Resources	Train washing will consume water and energy	<ol style="list-style-type: none"> To save water resource, rainwater harvesting structures will be constructed at Depot to receive runoff from sloping roof of the depot as well as recharge of ground water in uncovered land area. Rooftop solar panels on covered part of depots are proposed. As per Ministry of renewable Energy template, 5% of rooftop area of depot can generate 3.51 lakh kWh per year in Poonamallee Bypass depot. DG sets will be used as a standby power. If used, refer to Activity 48 "Use of DG sets" for further measures. 	GC / CMRL	GoTN

Sl. No.	Activity	Aspect / Parameter affected	Impact	Mitigation measures	Responsibility	
					Implementation	Supervision
		Surface /ground water Soil contamination	The wastewater discharges from workshops will have high oil & grease, high COD & TSS content	<ol style="list-style-type: none"> 1. No direct discharge to the municipal sewer system, the Sewage Treatment Plant (STP) and Effluent Treatment Plant (ETP) are planned at Depot. 2. The wastewater will be pretreated to meet regulatory requirements before being disposed in municipal sewer system. 3. Sewage will be generated from depot which could be treated up to the level so that it could be used for horticulture and non-drinking purposes in the Depot. 4. Oil spilled in Depot should be trapped in oil and grease trap and disposed to authorized collectors so as to avoid any underground/ surface water contamination. Oil that is mixed in water shall be removed in the ETP. 5. The solid waste generated from the Depot will be taken by the cleaning contractor weekly and disposed to the municipal waste disposal sites. 	GC / CMRL	GoTN
49.	Track repair	Environment	Spill accidents	<ol style="list-style-type: none"> 1. CMRL to ensure no illegal disposal of solid waste or wastewater. 	GC / CMRL	GoTN
50.	Use of DG sets	Air	Emission from DG sets will create air pollution problems	<ol style="list-style-type: none"> 1. DG sets compliant with CPCB norms will be used. 	GC / CMRL	GoTN
		Noise	Noise & vibration will be generated from the use of DG sets	<ol style="list-style-type: none"> 1. DG sets compliant with CPCB norms will be used. 2. Noise enclosures will be used. 3. Wherever baseline noise already exceeds the standards, only 3dB of noise increase is allowed. 	GC / CMRL	GoTN
		Groundwater	Diesel spillage (from underground or above ground storage facility) will affect groundwater quality adversely	<ol style="list-style-type: none"> 1. Diesel should be stored in designated sites prior to final relocation. 2. Oil that is mixed in water will be removed in the ETP. 	GC / CMRL	GoTN
		Health & safety	Storage of Diesel will attract the provisions of Hazardous	<ol style="list-style-type: none"> 1. Diesel should be stored in designated sites prior to final disposal. 	GC / CMRL	GoTN

Sl. No.	Activity	Aspect / Parameter affected	Impact	Mitigation measures	Responsibility	
					Implementation	Supervision
			Chemicals (Management & Handling) Rules and Petroleum Rules; as amended to date. It could cause serious damage to health & safety of workers / property if ignited	2. Fire fighter is equipped at storage site. 3. Proper onsite emergency plan will be prepared by GC and will be approved through CMRL.		
		Resources	DG sets will consume Diesel (and in effect reduce the levels of a non-renewable resource)	1. DG sets compliant with CPCB norms will be used only as backup.	GC / CMRL	GoTN
		Aesthetics	Operation of DG sets will cause an aesthetic issue	1. Enclosures will be used.	GC / CMRL	GoTN
51.	Development of feeder routes	Social	Along with Metro routes, metro feeder routes will be developed. This will have a positive impact in terms of enhanced connectivity and inclusion in the social mainstream	1. CMRL will work with bus operators to implement metro feeder routes along major arterial and sub-arterial routes to reduce travel time to the nearest station. Better quality coaches & comfortable rides should be planned to enhance acceptability.	GC / CMRL	GoTN
		Health & safety	Better & frequent transport system will reduce risk of traffic accidents	1. The new feeder routes should (a) follow proper timetable; (b) should have frequent services during the morning & evening peak;(c) should have a limited carrying capacity. The feeder buses should arrive and depart from designated bus bays or similar structures. Proper arrangements for road crossing should be established. The appointed personnel should assist passengers to reach their destinations. An easily accessible grievance redressal system should be established by CMRL.	GC / CMRL	GoTN
		Aesthetics	Better designed coaches will enhance ride pleasure and aesthetics	1. The buses should be properly maintained from time to time in order to enhance the aesthetic value.	GC / CMRL	GoTN

Sl. No.	Activity	Aspect / Parameter affected	Impact	Mitigation measures	Responsibility	
					Implementation	Supervision
52.	Generation of employment	Social	The proposed project will result into generation of employment	1. The project will cause direct and indirect employment generation. Economic activity will be stimulated by easier movement of passengers thus leading to indirect employment generation.	GC / CMRL	GoTN
53.	Ancillary development along metro route	Land	Ancillary developments will take place along with metro corridor	1. Provision for increased density of development along project corridor is available through existing byelaws as well as new ToD norms. Mixed land use of ToD tends to reduce non-work trip length and its higher density promotes increased use of metro for work trips on long distances. 2. Implementation of increased densities is decided by State Government and managed by CMDA in accordance with demand.	GC / CMRL	GoTN
		Social	Ancillary development along the metro alignment will have positive effect on the social environment	1. There should be positive participation of the common people in the ancillary development process. An open, transparent & people-centric outlook has to be adopted.	GC / CMRL	GoTN

Table 9-3: Environmental Monitoring Plan

Environmental Features	Aspect to be Monitored	Standard to be complied with	Time and Frequency of Monitoring	Location	Estimated cost (USD)
Pre-Construction stage					
Air	Emission of dust and particulate matter as PM _{2.5} and PM ₁₀ , NO _x and SO _x , CO	Gol and WHO/IFC whichever stringent	Once, 24 hours continuously	Each station, batching plant and casting yard, Muck disposal site	4,667
Water (Surface and Ground)	DO, Turbidity, Conductivity, pH, Heavy metals, E.Coli, TSS, Oil and Grease, VOCs and Volatile Chlorinated Hydrocarbons (groundwater only) and TDS	Gol and WHO/IFC whichever stringent	Once, 3 samples each location	Groundwater at batching plant and casting yard, Muck disposal site, construction camps and 30 excavation sites Surface water at wherever waterbody located within 100m from sites	11,400
Soil	pH, Sulphate (SO ₃), Chloride, ORP, water Soluble salts EC, Organic Matter (Oil), Heavy metals, Poly-Aromatic Hydrocarbons (PAH), Moisture Content	Gol and WHO/IFC whichever stringent	Once, 3 samples each location	At batching plant and casting yard, Muck disposal site, construction camps and 30 excavation sites	11,100
Noise, vibration b) Building condition survey	Noise levels in dB(A) Vibration PPV mm/s Building condition survey	Gol and WHO/IFC whichever stringent FTA Guideline Standards or any other internally recognized standards	a) Once Hourly basis for 24 hours (noise and vibration) b) Vibration: Once, X, Y and Z axis with a high accuracy triaxial sensor. Frequency range from 1 to 315Hz. Hourly basis for 24 hours	a) At key structure locations b) Key sections of line	a) 6,800 b) 178,091

Environmental Features	Aspect to be Monitored	Standard to be complied with	Time and Frequency of Monitoring	Location	Estimated cost (USD)
			b) Building Condition Survey: height measurements, crack survey, detailed photographic records etc.		
Sub-total					212,058
Construction stage					
Air	Emission of dust and particulate matter as PM _{2.5} and PM ₁₀ , NO _x and SO _x , CO	Gol and WHO/IFC whichever stringent	24 hours continuously every month	For each station until civil works completed batching plant and casting yard, Muck disposal site throughout construction phase	163,200
Water (Surface and Ground)	DO, Turbidity, Conductivity, pH, Heavy metals, TN, TP, E.Coli, TSS, Oil and Grease, VOCs (groundwater only) and TDS	Gol and WHO/IFC whichever stringent	Quarterly, 3 samples each location	Groundwater at batching plant and casting yard, Muck disposal site, construction camps throughout construction phase, and excavation sites stations until civil works completed Surface water at wherever waterbody located within 100m from sites	132,000
Soil	PH, Sulphate (SO ₃), Chloride, ORP, water Soluble salts EC, Organic Matter (Oil), Heavy metals, PAH, Moisture Content	Gol and WHO/IFC whichever stringent	Quarterly, 3 samples each location	At batching plant and casting yard, Muck disposal site, construction camps throughout construction phase 30 excavation sites-once during construction, once post-construction	30,000

Environmental Features	Aspect to be Monitored	Standard to be complied with	Time and Frequency of Monitoring	Location	Estimated cost (USD)
Noise, and Vibration Subsidence	a) Noise levels in dB(A) b) Vibration PPV mm/s c) Deformation monitoring				
Gol and WHO/IFC whichever stringent					
FTA Guideline Standards or any other internally recognized standards	a) Monthly or when complaint is received Hourly basis for 24 hrs (noise) b) Continuous monitoring when the TBM is within 10meters from the structure (vibration) c) Subsidence: building conditions, crack sensors, tilt sensors, continuous height measurement etc.	At key structure locations	a) and b)12,960 c) To be included by Construction contractor in his bid		
Occupational and Community Health and Safety	As specified in project ESHS plan prepared by Contractor Sub-section F of Section VII and Part D of PCC	IFC General and Sector EHS Guidelines or any other international recognized guidelines	Weekly	Project Site	NA
Sub-total					338,160
Operation Stage					
Air	Emission from DG sets (PM ₁₀ , PM _{2.5} NO _x and SO _x), Odor	Gol and WHO/IFC whichever stringent	At least 2 times in a year for the first year, annually for another 2 years	Ventilations of UG Stations, DG sets of all stations and Depot	16,533
Groundwater	DO, Turbidity, Conductivity, pH, Heavy metals, TP, TN, E.Coli, TSS, Oil and Grease, VOCs and TDS	Gol and WHO/IFC whichever stringent	At least 2 times in a year for the first year, annually for another 2 years	Groundwater at Station locations and depot	12,400

Noise	Noise levels in dB(A)	Gol and WHO/IFC whichever stringent	At least 2 times in a year for the first year, annually for another 2 years	Alignment, Stations, Depot	3,733
Vibration	PPV mm/s	FTA Guideline Standards or any other internally recognized standards	At least 2 times in a years for the first year, annually for another 2 years	At key structure locations	16,000
Occupational Health and Safety	As specified in project EMP and CMRL's SHE Manual	IFC General and Sector EHS Guidelines or any other international recognized guidelines	Monthly for 3 years	Station and Depot	20,000*
Sub-total					68,666
Grand total					618,884

During construction:

Noise: 2 construction yards on Bypass and Santhome Basilica and 4 locations between Saraswathi school to Government Hospital;

Vibration: 3 receptors from underground section namely St Thomas Basilica, Rosary Church and Our Lady of Light Shrine which are all heritage structures; and Baseline Building Condition Survey from Foreshore Estate station to Thirumayilai station and Bharathidasan Road station to Panagal Park station.

During operation:

Occupational Health and Safety safeguards during operation are not spelt out in the SHE document. Based on experience on other railways, health issues relevant to Chennai metro can be as follows: a) Musculo-skeletal disorders and fatigue, eye strain due to Display Screens impacting drivers, train controllers and ticketing staff: Well-designed workstations, lighting, posture advice and regular health checkups. b) Stress impacting drivers and Train controllers: Risk assessment, changes to job design, task allocation, training, and supervision; emotional resilience training; counselling for recovery and rehabilitation.

*** Lumpsum provision Group Insurance premium excluding surgeries and loss of life or limb: Rs five lakh per yea****9.5 Emergency Preparedness and Response System**

317. An Emergency Preparedness and Response System has been prepared as shown in Table 9.4.

Table 9-4: Emergency Preparedness and Response System

Emergency Situations	Community or individuals impacted	Response procedure	Equipment and resources	Responsibilities	Training need	Accident and emergency records
Damage to utilities: Damage to one of the utilities water	Community In case of live gas	<ul style="list-style-type: none"> The potential for disruption of utilities during line construction is low as long as proper pre-dig verification procedures are 	<ul style="list-style-type: none"> For gas utilities Fire engines to dispense water and foam 	Notification: Contractor to CMRL and utility agency	<ul style="list-style-type: none"> Mock drills Use of extinguishers, fire suits, 	<ul style="list-style-type: none"> Utility location and diversion plans Record sheet showing type, size and

Emergency Situations	Community or individuals impacted	Response procedure	Equipment and resources	Responsibilities	Training need	Accident and emergency records
<p>supply, sewage, gas pipelines; electric and telecommunication cables while other utilities are being diverted due to lack of clarity in their location or unexpectedly poor state of their maintenance. Damage while additional geotechnical investigations are in progress or during pile driving/in-situ casting.</p>	<p>lines, the project workforce could also be impacted</p>	<p>followed. Disruption could range from cable or phone outage to customers, to explosion in gas line with potential risk to human health and life.</p> <ul style="list-style-type: none"> • Contact utility to clear utility related safety hazard (like deactivating the utility). • Seek assistance of the utility to assess damage • Coordinate with un-impacted utilities. • Vital services and infrastructure recovery activities. 	<ul style="list-style-type: none"> • Portable extinguishers • Fire protection suits • Breathing apparatus, helmets, goggles and face shield, first aid kits, stretchers, torches, ladders, emergency lighting on standby power <p>➤For water and sewage utilities</p> <ul style="list-style-type: none"> • Quick water sealants 	<p>CMRL to utility agency</p> <p>Remedial Action by: utility agency</p>	<p>breathing apparatus, first aid kits, water sealants</p>	<p>identification number of utility, time of occurrence, time of notifying utility agency, status of other utility lines at the locations, time of repair and resumption of construction activities</p> <ul style="list-style-type: none"> • Geotagged photographs with date
<p>Ground subsidence due to unanticipated degree of groundwater drawdown</p>	<p>Community</p>	<p>The base document available with the ER Team shows the location of structures which are at risk of subsidence as assessed at start of construction.</p>	<ul style="list-style-type: none"> • Helmets, first aid kits, stretchers, torches, ladders, emergency lighting on standby power, tents 	<p>Notification: Contractor to CMRL</p> <p>Remedial Action by: Contractor</p>	<ul style="list-style-type: none"> • Mock drills • Use of first aid kits 	<ul style="list-style-type: none"> • Plan showing location of construction site and affected structures • Groundwater drawdown records from borewells • Vibration records • Record sheet showing type, size and identification number of structure, time of
<p>Ground subsidence under existing structures during tunneling due to unanticipated</p>	<p>Community</p>	<p>In the event of subsidence, move occupants of structures affected as well as those in their proximity to safer locations. Arrange for their temporary relocation till the structures are rehabilitated.</p>		<p>Notification: Contractor to CMRL</p> <p>Remedial Action by: Contractor</p>		

Emergency Situations	Community or individuals impacted	Response procedure	Equipment and resources	Responsibilities	Training need	Accident and emergency records
weak pockets of substratum						occurrence, type of equipment in use before and when the damage was first noticed, the type of minor repair executed, number of occupants present and evacuated, time of evacuation, status of adjacent structures, type of rehabilitation implemented on each affected structure, date of resumption of construction activities, date of return of occupants
Collapse or severe degree of damage to existing structures due to unanticipated vibration during construction	Community	<ul style="list-style-type: none"> The base document available with the ER Team shows the location of structures which are at risk of damage due to vibration as assessed at start of construction. <p>In case of those structures where damage is expected to be major especially due to age or condition of building, move occupants affected as well as those in their proximity to safer locations <i>before work is started at those locations</i>. Arrange for their temporary relocation till the structures are rehabilitated.</p> <ul style="list-style-type: none"> In the event of minor damage to non-structural elements of the buildings, the same will be repaired. In case of <i>unforeseen damage</i> endangering structural soundness, move occupants of structures affected as well as those in their proximity to safer locations. <p>Arrange for their temporary relocation till the structures are rehabilitated.</p>		<p>Notification: Contractor to CMRL</p> <p>Remedial Action by: Contractor</p>	<ul style="list-style-type: none"> Mock drills 	<p>status of adjacent structures, type of rehabilitation implemented on each affected structure, date of resumption of construction activities, date of return of occupants</p> <ul style="list-style-type: none"> Geotagged photographs with date
Premature activation of	Project workforce			Notification: Contractor to CMRL	<ul style="list-style-type: none"> Mock drills 	<ul style="list-style-type: none"> Record sheet showing location and

Emergency Situations	Community or individuals impacted	Response procedure	Equipment and resources	Responsibilities	Training need	Accident and emergency records
blasting, collapse of weak rock strata				Remedial Action by: Contractor	<ul style="list-style-type: none"> • Air quality monitoring • First Aid • Use of Breathing apparatus, fire suit 	time of occurrence, type and configuration of explosive, number of personnel present and evacuated <ul style="list-style-type: none"> • Geotagged photographs with date
Fire and explosion of flammable gases, flooding during underground works	Project workforce	<ul style="list-style-type: none"> • The source of fire and explosions could be fuel stored underground or gas pockets. Use fire water and foam to combat fires of oil. Immediately cool the construction equipment and any gas containers to avoid explosion. • Headcount • Search and Rescue • Administer first aid • Gas monitoring • Block tunnel to prevent unauthorized personnel from entering the tunnel to facilitate rescue and reduce exposure to secondary explosions. • Lay ventilation ducts and send fresh air to reduce gas concentration. • Grouting, foam injection for gassy outburst and water inflow. 	<ul style="list-style-type: none"> • Emergency Lighting on standby • Power Equipment and Rescue Equipment • Breathing apparatus • Gas detector • Fire Proximity suit • First Aid Kit • Stretchers • Torches and Ladders • Ambulance • Standby non-sparking ventilation fans to evacuate gases and smoke from the underground works. • Standby high power pumps to evacuate flood water from the 	Notification: Contractor to CMRL and Fire Department, Police, hospitals and Tamil Nadu Pollution Control Board Remedial Action by: Contractor	<ul style="list-style-type: none"> • Water seal • Evacuation • Search and Rescue 	<ul style="list-style-type: none"> • Plan of construction yards and sites showing designated men assembly areas, Emergency Vehicle parking areas and roads • Air and gas sample test reports • Record sheet showing location and time of occurrence, number of personnel present and evacuated • Geotagged photographs with date

Emergency Situations	Community or individuals impacted	Response procedure	Equipment and resources	Responsibilities	Training need	Accident and emergency records
			underground works • Quick water sealants • Safety Equipment • Gum Boots • Safety Helmets • Rubber Hand Gloves • Goggles and face shield • Wind Direction Indicator • Ropes and harnesses ➤ Depending on the number of workers underground, one or two rescue teams – one at jobsite and one near the site.			
Fire accidents at electric installations, fuel storage and fueling facilities	Community and project workforce	<ul style="list-style-type: none"> • Transformer or Substation fire requires equipment be de-energised. • Use fire water and foam to combat fires of oil. • Immediately cool the equipment and any containers to avoid explosion. 	<ul style="list-style-type: none"> • Fire engines to dispense water and foam • Portable extinguishers • Fire protection suits • Breathing apparatus, 	Notification: Contractor to CMRL and Fire Department, Police, hospitals and Tamil Nadu Pollution Control Board Remedial Action by:	<ul style="list-style-type: none"> • Mock drills • First Aid • Use of fire extinguishers, fire suits, breathing apparatus • Evacuation 	<ul style="list-style-type: none"> • Fuel and vapour sample test reports • Maintenance reports of electric and fuel installations • Record sheet showing location and time of occurrence,

Emergency Situations	Community or individuals impacted	Response procedure	Equipment and resources	Responsibilities	Training need	Accident and emergency records
		<ul style="list-style-type: none"> Follow designated standoff distance and stand down period. Administer first aid 	helmets, goggles and face shield, first aid kits, stretchers, torches, ladders, Emergency lighting on standby power	Contractor	<ul style="list-style-type: none"> Search and Rescue 	number of personnel present and evacuated <ul style="list-style-type: none"> Geotagged photographs with date
Road accident hazard due to leakage of hazardous waste such as waste fuels, lubricants during transport by vendors	Community and project workforce	<ul style="list-style-type: none"> Even if grievous hurt and loss of life to workers and community and property is not caused, if incident occurred in public area posing a hazard, notify Police and alert Pollution Control Board. Control the leak/flow Arrange for sampling of any water pollution or potential pollution 	<ul style="list-style-type: none"> First aid kits, stretchers, torches, ladders, emergency lighting on standby power 	Notification: Contractor to CMRL • CMRL to Traffic Police and Tamil Nadu Pollution Control Board. Remedial Action by: Contractor	<ul style="list-style-type: none"> Mock drills First Aid Use of fire extinguishers, fire suits, breathing apparatus 	<ul style="list-style-type: none"> Waste identification report Record sheet showing location and time of occurrence, number of personnel present and evacuated Geotagged photographs with date
Air pollution due to leakage and fire of flammable gases from muck disposal site slope failure of muck stack at disposal site	Community and project workforce	<ul style="list-style-type: none"> Even if grievous hurt and loss of life to workers and community and property is not caused, if incident occurred in public area posing a hazard, notify Police and alert Pollution Control Board. Use fire water 	<ul style="list-style-type: none"> Fire engines to dispense water and foam Portable extinguishers Fire protection suits Breathing apparatus, gas detectors, helmets, goggles and face shield, first aid kits, stretchers, torches, ladders, Emergency lighting on standby power 	Notification: Contractor to CMRL and Fire Department CMRL to Tamil Nadu Pollution Control Board Remedial Action by: Contractor	<ul style="list-style-type: none"> Mock drills 	<ul style="list-style-type: none"> Gas sample test reports Record sheet showing location and time of occurrence, number of personnel present and evacuated Geotagged photographs with date

Emergency Situations	Community or individuals impacted	Response procedure	Equipment and resources	Responsibilities	Training need	Accident and emergency records
Failed launching of pre-cast girders or segments	Community and project workforce	<ul style="list-style-type: none"> • Administer first aid • Organise lifting equipment and gas cutters • Even if grievous hurt and loss of life to workers and community and property is not caused, but if collapse occurred in public area posing a hazard, notify Police. 	<ul style="list-style-type: none"> • Lifting equipment and gas cutters • First aid kits, stretchers, torches, ladders, emergency lighting on standby power 	Notification: Contractor to CMRL CMRL to Police and district labour Commissioner Remedial Action by: Contractor	<ul style="list-style-type: none"> • Mock drills • First Aid • Search and Rescue 	<ul style="list-style-type: none"> • Structural drawings of failed elements • Record sheet showing location and time of occurrence, type of lifting equipment used, number of personnel present and evacuated • Geotagged photographs with date
Collapse of temporary works such as scaffolding and excavation support	Community and project workforce	In case of injured worker suspended from his harness, wait for trained emergency personnel.		Notification: Contractor to CMRL CMRL to Police and district labour Commissioner Remedial Action by: Contractor	<ul style="list-style-type: none"> • Mock drills • First Aid 	<ul style="list-style-type: none"> • Structural drawings of failed temporary works • Record sheet showing location and time of occurrence, number of personnel affected • Geotagged photographs with date
Health and safety impacts due to failure of ventilation in underground station	Metro Passengers and employees	<ul style="list-style-type: none"> • Notify Operational Control Centre (OCC) and suspend boarding and alighting in affected station; let trains pass through. • Administer first aid • Close entry of passengers into affected stations • Evacuate passengers. 	<ul style="list-style-type: none"> • Standby non-sparking ventilation fans to ventilate • Breathing apparatus for vulnerable passengers • Maintenance equipment, spares and personnel 	Notification: CMRL to Emergency Action Committee Remedial Action by: CMRL	<ul style="list-style-type: none"> • Mock drills • First Aid • Use of breathing apparatus • Evacuation 	<ul style="list-style-type: none"> • Ventilation system readings • Ventilation system maintenance reports • Record sheet showing location and time of occurrence, number of persons affected • Geotagged photographs with date

Emergency Situations	Community or individuals impacted	Response procedure	Equipment and resources	Responsibilities	Training need	Accident and emergency records
Service disruption and unplanned congestion due to failure of platform screen doors or rolling stock doors	Metro Passengers	<ul style="list-style-type: none"> As soon as duration of failure approaches disruption period allowed in station design, notify OCC and suspend boarding and alighting at affected station close entry of passengers into affected stations Trains arriving in affected duration will pass without stopping Affected trains will pass through to maintenance depot for attention 	Maintenance equipment, spares and personnel	Notification: CMRL to Emergency Action Committee Remedial Action by: CMRL	<ul style="list-style-type: none"> Mock drills 	<ul style="list-style-type: none"> PSD and rolling stock usage log PSD and rolling stock maintenance reports Record sheet showing location and time of occurrence, number of services affected Geotagged photographs with date
Service disruption and unplanned congestion due to failure of traction power supply or signaling during operation of the Metrorail	Metro Passengers	<ul style="list-style-type: none"> In case of traction power failure, affected trains reach nearest station on battery. In case of signalling failure, stop affected trains at nearest station. Suspend operation of trains bound to pass through affected stations or section; stop trains at stations outside affected section Close entry of passengers into affected stations 	Maintenance equipment, spares and personnel	Notification: CMRL to Emergency Action Committee Remedial Action by: CMRL	<ul style="list-style-type: none"> Mock drills 	<ul style="list-style-type: none"> TPS and S&T log TPS and S&T maintenance reports Record sheet showing location and time of occurrence, number of services affected Geotagged photographs with date
Unplanned congestion in stations due to failure of general power through grid supply for lighting, communication etc	Metro Passengers	<ul style="list-style-type: none"> As soon as standby supply is activated, notify OCC and suspend boarding and alighting in affected station; let trains pass through. Close entry of passengers into affected stations 	<ul style="list-style-type: none"> Handheld 2 way radios and hailing loudspeakers Portable handheld lamps Maintenance equipment, spares and personnel 	Notification: CMRL to Emergency Action Committee Remedial Action by: CMRL	<ul style="list-style-type: none"> Mock drills 	<ul style="list-style-type: none"> Standby system maintenance reports Record sheet showing location and time of occurrence Geotagged photographs with date

Emergency Situations	Community or individuals impacted	Response procedure	Equipment and resources	Responsibilities	Training need	Accident and emergency records
		<ul style="list-style-type: none"> • Switch on battery-powered high-power lamps which have been fixed to stations structure • Use portable hailers to address passengers and employees • Use portable lamps to locate and evacuate passengers and employees. 				
Fire in underground section		<ul style="list-style-type: none"> • In case of manual or semi-automatic ventilation systems, operator to activate ventilation upon detection of fire In case of fire in station: <ul style="list-style-type: none"> • Suspend operation of trains bound to pass through affected stations or section: stop trains at stations upstream and downstream of affected station. • Render First Aid • Close entry of passengers into affected station In case of fire in train: <ul style="list-style-type: none"> • Drive the train on fire to the platform of the next station without stopping at intermediate sections to evacuate the passengers and carry out fire-fighting activities there. • Once notified by the driver of the train on fire, the OCC will direct the train in front of the train on fire to proceed to the next station and the train running behind the train on fire to stop. 	<ul style="list-style-type: none"> • Fire protection suits • Breathing apparatus, gas detectors, helmets, goggles and face shield, first aid kits, stretchers, torches, ladders 		<ul style="list-style-type: none"> • Mock drills • First Aid • Use of fire suits, breathing apparatus • Evacuation • Search and Rescue 	<ul style="list-style-type: none"> • Record sheet showing location and time of occurrence, number of services affected • Geotagged photographs with date

Emergency Situations	Community or individuals impacted	Response procedure	Equipment and resources	Responsibilities	Training need	Accident and emergency records
		<p>Trains running on the opposite track will also be directed not to access or stop at the station where the train on fire arrives.</p> <ul style="list-style-type: none"> • If the train on fire stops at the station or the station is burning, the train dispatcher shall direct other trains not to approach this station. • In case evacuation becomes necessary while train is in tunnel, passengers will be asked to exit through side doors onto the inspection gallery in the tunnel. 				
<p>Flooding of underground stations due to unanticipated sea level rise or failure of pumping equipment</p>	<p>Metro Passengers</p>	<ul style="list-style-type: none"> • At times of extreme sea level rise based on alerts from meteorological department, deploy trained rescue teams at vulnerable stations • As soon as flooding is imminent, notify Operation Control Centre to suspend operation of trains bound to pass through affected stations or section; stop trains at stations outside affected section • Administer first aid • Notify nearby hospitals for ambulances • Evacuate trains which have been stopped • Close entry of passengers into affected stations 	<ul style="list-style-type: none"> • Trained rescue teams at vulnerable stations • Inflatable life jackets • Portable lamps and hailers • 2 way radios • Battery-powered high-power lamps fixed to station structure 	<p>Notification: CMRL to Emergency Action Committee, Police, State Government</p> <p>Remedial Action by: CMRL</p>	<ul style="list-style-type: none"> • Mock drills • First Aid • Use of breathing apparatus, life jackets • Evacuation • Search and Rescue 	<ul style="list-style-type: none"> • Maintenance records of pumps • Record sheet showing location and time of occurrence, number of services affected • Geotagged photographs with date

Emergency Situations	Community or individuals impacted	Response procedure	Equipment and resources	Responsibilities	Training need	Accident and emergency records
		<ul style="list-style-type: none"> • Switch on battery-powered high-power lamps which have been fixed to stations structure • Disconnect grid and standby DG power supply with turnstiles in default open mode. • Use portable hailers to address passengers and employees • Use portable lamps to locate and evacuate passengers and employees. 				
<p>Service disruption, Grievous hurt, loss of life due to natural disasters such as unanticipated earthquakes</p>	<p>Community and Metro Passengers</p>	<ul style="list-style-type: none"> • Notify Operation Control Centre to suspend operation of trains bound to pass through affected stations or section; stop trains at stations outside affected section • Administer first aid • Notify nearby hospitals for ambulances and to standby • Evacuate trains which have been stopped • Close entry of passengers into affected stations • Switch on battery-powered high-power lamps which have been fixed to station structure • Disconnect grid and standby DG power supply with turnstiles in default open mode. • Use portable hailers to address passengers and employees 	<ul style="list-style-type: none"> • Trained rescue teams • Emergency battery fixed lighting • Hand torches • First Aid Kits • Safety helmets • Ropes and safety harnesses • Stretchers • Ladders • Ambulance • Rail-cum-road Vehicles 	<p>Notification: CMRL to Emergency Action Committee, hospitals, Police, State Government, Commissioner Metro Rail Safety (CMRS) *</p> <p>Remedial Action by: CMRL</p>	<ul style="list-style-type: none"> • Mock drills • First Aid • Evacuation • Search and Rescue 	<ul style="list-style-type: none"> • Magnitude and epicenter of earthquake • Seismic design adopted in design of structures • Record sheet showing location and time of occurrence, number of persons affected • Geotagged photographs with date

Emergency Situations	Community or individuals impacted	Response procedure	Equipment and resources	Responsibilities	Training need	Accident and emergency records
		<ul style="list-style-type: none"> • Use portable lamps to locate and evacuate passengers and employees. 				
<p>Unplanned congestion in stations due to terrorism or sabotage or law and order situations on Metro project or outside Metro project</p>	<p>Community, Metro Passengers and employees</p>	<ul style="list-style-type: none"> • Notify Operation Control Centre to suspend operation of trains bound to pass through affected stations or section; stop trains at stations outside affected section • Administer first aid • Notify nearby hospitals for ambulances and to standby • Evacuate trains which have been stopped • Close entry of passengers into affected stations 	<ul style="list-style-type: none"> • First Aid Kits • Stretchers • Ambulance 	<p>Notification: CMRL to Emergency Action Committee, hospitals, Police, State Government</p> <p>Remedial Action by: CMRL</p>	<ul style="list-style-type: none"> • Mock drills • First Aid • Evacuation • Search and Rescue 	<ul style="list-style-type: none"> • Record sheet showing location and time of occurrence, number of persons affected • Geotagged photographs with date
<p>Grievous hurt, loss of life and property due to terrorism or sabotage or law and order situations on Metro project</p>				<p>Notification: CMRL to Emergency Action Committee, hospitals, Police, State Government, CMRS*</p> <p>Remedial Action by: CMRL</p>		
<p>Acts of suicide or murder or hurt</p>	<p>Perpetrators and victims</p>	<ul style="list-style-type: none"> • Notify OCC and suspend operation of trains on affected platform; stop trains at stations outside affected section • Administer first aid • Notify nearby hospitals for ambulance and to standby 	<ul style="list-style-type: none"> • First Aid Kits • Stretchers • Ambulance 	<p>CMRL to Emergency Action Committee, hospitals, Police, State Government, CMRS*</p> <p>Remedial Action by: CMRL</p>	<ul style="list-style-type: none"> • Mock drills • First Aid • Evacuation 	

* Metro Railway (Operations and Maintenance) Act, 2002 requires reporting of a) collision or derailment of trains or b) accidents attended or usually attended by loss of life or grievous hurt

9.6 Training and Capacity Building Programs

318. CMRL's current capacity in monitoring of metro projects is adequate. However it is proposed to conduct a training program for CMRL as well as general consultant and contractors environmental, health and safety officials particularly on MDBs' monitoring and reporting requirements. External monitor will undertake training and capacity building activities. Training modules will be discussed and confirmed by CMRL and MDBs. A budget has been allocated in the EMP for the same.

9.7 Environmental Management Budget and Resources

319. The cost of all compensation and rehabilitations works will be an integrated part of the overall project cost, which will be borne by the project. The preliminary estimated cost of the environmental and social management plan is estimated as below. This cost estimate is exclusive of land acquisition and resettlement & resettlement cost.

Table 9-5: Cost of EMP and EMoP Implementation*

Sl. No.	Item/Particular	Cost (Rs in Lakh)
1.	Rainwater Harvesting	451.89
2.	Air, Noise, vibration, Water, Soil monitoring during construction and operation *	464.16
3.	Environment Division	290.00
4.	Tree Plantation	101.30
5.	Sewage Treatment Plant	33.79
6.	Effluent Treatment Plant	45.00
7.	Training and capacity building	6.40
8.	Rooftop Solar Plant	886.32
	Total	2,278.86

* Does not include cost of monitoring of building condition survey during construction and ecological monitoring. The Noise barriers will be part of civil work cost.

10 CONCLUSION AND RECOMMENDATION

320. The alignment of the proposed Chennai Metro Corridor 4 and depot area are carefully selected to avoid most of the sites having historical/cultural significance. Three religious structures/ churches shall have vibration impact, however appropriate management measures has been given in the EMP for mitigating the same. Some impacts are anticipated due to cutting of about 536 public trees for which compensatory afforestation in the ratio of 1:12 has been proposed. Nearly 2249m length of alignment traverses through CRZ area (932m of CRZ II and 50m of CRZ IV-B), for which CRZ clearance shall be obtained and the given conditions in the clearance shall be strictly adhered to. Ecological restoration plan has been suggested for Panagal Park. Other necessary clearance/ NOCs/ permissions for construction shall be obtained by the contractor under the supervision of the GC and CMRL.

321. Significant adverse impacts of `medium to high` risk and `likely to definite` likelihood are a) social impacts due to involuntary resettlement, b) loss of trees, c) utility diversion, d) air, noise, vibration, muck and waste disposal, labour safety, water demand, ground subsidence due to construction; and e) noise, vibration and ground subsidence due to operation. Measures to mitigate adverse impacts have been recommended In the EMP, which shall also forms part of the bid document. Further noise and vibration study has been conducted based on the detailed engineering design. This is meant to inform the incremental impacts and proposed mitigation measures. This was completed as part of the supplementary study of this EIA by contractors' mobilization.

322. Benefits include reduced air pollution and road accident, increased benefits to economy and commuters on metro and road. Major roads along the proposed alignments are forecast to function beyond respective design service volume in year 2035 in absence of the project lines. BRT has significantly lower unit life cycle cost but road right of way is not adequate to operate BRT on Corridor 4. Therefore continuity of Metro is required. Requirement of acquisition of property was minimized by fine-tuning of locations and footprint of stations.

323. Public consultations highlighted opinions of participants on benefits of Metro in terms of easing connectivity, pollution, congestion, accidents and travel on roads and safe travel for women; and apprehensions about impact of tunneling on existing buildings and loss of green cover; suggestions for moderate metro fare compensation for impacted shops and other properties. Public consultations during construction and operation will form part of periodic reports sent by CMRL to MDBs. These consultations will focus on the efficacy of mitigation measures being implemented.

324. Grievance Redress Mechanism will be developed to assist the citizens, users of the Metro and other stakeholders communicate their queries, complaints and suggestions in connection with implementation of EMP and EMoP. GRM for both workers and communities will be instituted during pre-construction phase to continue through different phases.

325. Institutional arrangement, EMP, reporting and record keeping, emergency response and environment monitoring plan have been developed. Budgetary cost estimate to implement the EMP and EMoP has been prepared.

326. Best available technology and best management practices are built-in to the project design. All project components will be implemented and monitored in line with the MDBs' applicable policies and standards. A semi-annual environmental and social monitoring report will be submitted to MDBs and will be disclosed publicly at the MDBs' websites. Environmental and social benefits of the project and long-term investment program objectives outweigh the temporary negative impacts